



# Service & Parts Manual

## 1330SE

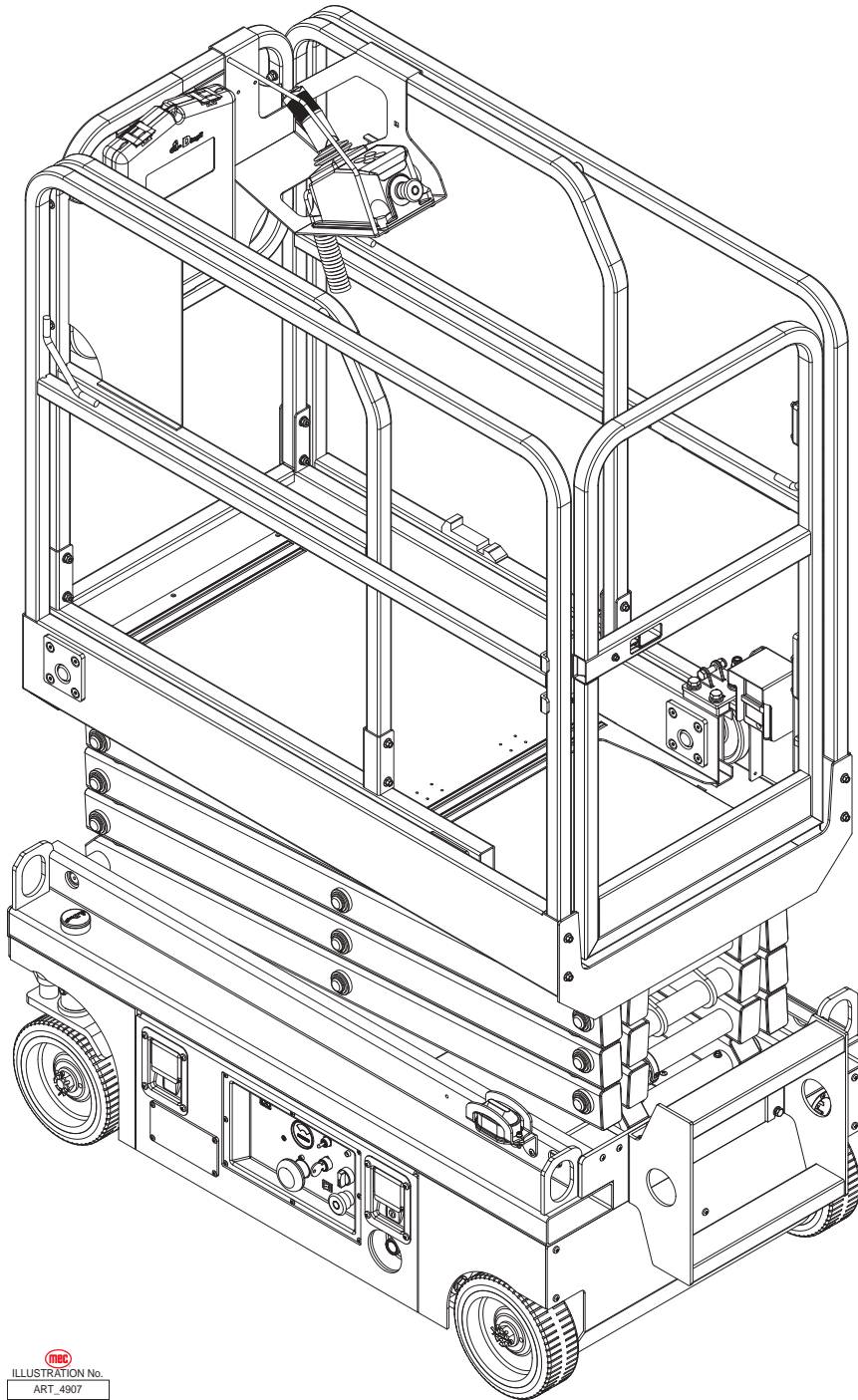

  
ILLUSTRATION No.  
ART\_4907

Meets requirements of ANSI A92.20-2020 and CSA B354.6-2019.  
Serial Number Range 16307700 - Up

Part # 95834  
October 2024

---

## Revision History

Date	Reason for Update
November 2021	New Release



# MEC Aerial Work Platforms

---

1401 S. Madera Avenue, Kerman, CA 93630 USA  
Toll Free: 1-877-632-5438  
Phone: 1-559-842-1500  
Fax: 1-559-842-1520  
info@MECawp.com  
www.MECawp.com

# Table of Contents

Chapter 1 - Service . . . . .	1
<i>Service Introduction</i> . . . . .	1
<b>Section 1 - MEC Operator Policy</b> . . . . .	<b>2</b>
<i>MEC Operator Policy</i> . . . . .	2
<b>Section 2 - Safety Symbols &amp; General Safety Tips</b> . . . . .	<b>3</b>
<i>Safety Symbols &amp; General Safety Tips</i> . . . . .	3
<b>Section 3 - Torque Specifications</b> . . . . .	<b>4</b>
<i>Bolt Torque Specification - American Standard</i> . . . . .	4
<i>Bolt Torque Specification - Metric Standard</i> . . . . .	5
<i>Hydraulic Components Torque Table</i> . . . . .	6
<b>Section 4 - Specifications</b> . . . . .	<b>7</b>
<i>Specifications</i> . . . . .	7
<b>Section 5 - Maintenance Lock</b> . . . . .	<b>8</b>
<i>Maintenance Lock</i> . . . . .	8
<b>Section 6 - Machine Systems</b> . . . . .	<b>9</b>
<i>Machine Systems</i> . . . . .	9
<b>Section 7 - Primary Machine Components.</b> . . . . .	<b>10</b>
<i>Primary Machine Components</i> . . . . .	10
<b>Section 8 - Emergency Systems and Procedures.</b> . . . . .	<b>11</b>
<i>Emergency Systems and Procedures</i> . . . . .	11
<b>Section 9 - Transport and Lifting Instructions.</b> . . . . .	<b>12</b>
<i>Free-Wheel Configuration for Winching or Towing</i> . . . . .	12
<i>Lift and Support the Machine</i> . . . . .	13
<b>Section 10 - Maintenance</b> . . . . .	<b>14</b>
<i>Maintenance</i> . . . . .	14
<i>Pre-Start Inspection Checklist</i> . . . . .	16
<i>Frequent Inspection Checklist</i> . . . . .	17
<i>Annual Inspection Checklist</i> . . . . .	23
<i>Maintenance Inspection Report</i> . . . . .	26
<b>Section 11 - Control System</b> . . . . .	<b>27</b>
<i>Control Component Locations</i> . . . . .	27
<i>Fault Codes</i> . . . . .	28
<i>Error Indicator Readout</i> . . . . .	29
<b>Section 12 - Schematics</b> . . . . .	<b>32</b>
<i>Hydraulic Schematic</i> . . . . .	32
<i>Hydraulic Unit</i> . . . . .	33
<i>Electrical Schematic</i> . . . . .	34

Chapter 2 - Parts . . . . .	35
<i>Parts Introduction</i> . . . . .	35
<b>Section 13 - Chassis.</b> . . . . .	<b>36</b>
<i>Steer Linkage and Wheels Assembly, To Serial #16308570</i> . . . . .	36
<i>Steer Linkage and Wheels Assembly, From Serial #16308571</i> . . . . .	38
<i>Drive Wheel Assembly, To Serial #16308570</i> . . . . .	40
<i>Drive Wheel Assembly, From Serial #16308571</i> . . . . .	42
<i>Pothole Protection Assembly</i> . . . . .	44
<i>Battery Pack Module, To Serial #16308570</i> . . . . .	46
<i>Battery Pack Module, From Serial #16308571</i> . . . . .	48
<i>Hydraulic Power Unit</i> . . . . .	50
<i>Motor Controller Assembly</i> . . . . .	52
<i>Ground Control Assembly</i> . . . . .	54
<i>Chassis and Accessories, To Serial #16308570</i> . . . . .	56
<i>Chassis and Accessories, From Serial #16308571</i> . . . . .	58
<b>Section 14 - Scissor</b> . . . . .	<b>60</b>
<i>Scissor Assembly</i> . . . . .	60
<b>Section 15 - Platform</b> . . . . .	<b>62</b>
<i>Main Platform Assembly</i> . . . . .	62
<i>Platform Extension Assembly</i> . . . . .	64
<i>Platform Control Assembly</i> . . . . .	66
<i>Platform Control Box Assembly</i> . . . . .	68
<i>Platform Locking Device Assembly</i> . . . . .	70
<b>Section 16 - Hydraulics</b> . . . . .	<b>72</b>
<i>Lift Cylinder Assembly</i> . . . . .	72
<i>Hydraulic Hoses and Fittings</i> . . . . .	74
<b>Section 17 - Electrical System</b> . . . . .	<b>76</b>
<i>Electrical Harness, To Serial #16308570</i> . . . . .	76
<i>Electrical Harness, From Serial #16308571</i> . . . . .	78
<i>Power to Platform</i> . . . . .	80
<b>Section 18 - Options.</b> . . . . .	<b>82</b>
<i>900W Inverter</i> . . . . .	82
<i>Leak Containment System.</i> . . . . .	84
<b>Section 19 - Decals</b> . . . . .	<b>86</b>
<i>Decals</i> . . . . .	86

---

## Service Introduction

This Service section is designed to provide you, the customer, with the instructions needed to properly maintain the MEC self-propelled aerial work platform. When used in conjunction with the illustrated Parts section in this manual and the Operator's Manual (provided separately), this manual will assist you in making necessary adjustments and repairs, and identifying and ordering the correct replacement parts.

All parts represented here are manufactured and supplied in accordance with MEC quality standards. We recommend that you use genuine MEC parts to ensure proper operation and reliable performance.

To obtain maximum benefits from your MEC Aerial Work Platforms, always follow the proper operating and maintenance procedures. Only trained authorized personnel should be allowed to operate or service this machine. Service personnel should read and study the Operator's, and the Service and Parts Manuals in order to gain a thorough understanding of the unit prior to making any repairs.

## MEC Operator Policy

**Note:** *The best method to protect yourself and others from injury or death is to use common sense. If you are unsure of any operation, **don't start** until you are satisfied that it is safe to proceed and have discussed the situation with your supervisor.*

Service personnel and machine operators must understand and comply with all warnings and instructional decals on the body of the machine, at the ground controls, and platform control console.



**MODIFICATIONS OF THIS MACHINE FROM THE ORIGINAL DESIGN AND SPECIFICATIONS WITHOUT WRITTEN PERMISSION FROM MEC ARE STRICTLY FORBIDDEN. A MODIFICATION MAY COMPROMISE THE SAFETY OF THE MACHINE, SUBJECTING OPERATOR(S) TO SERIOUS INJURY OR DEATH.**

MEC's policies and procedures demonstrate our commitment to Quality and our relentless ongoing efforts towards Continuous Improvement, due to which product specifications are subject to change without notice.

Any procedures not found within this manual must be evaluated by the individual to assure oneself that they are "proper and safe."

Your MEC Aerial Work Platform has been designed, built, and tested to provide many years of safe, dependable service. Only trained, authorized personnel should be allowed to operate or service the machine.

MEC, as manufacturer, has no direct control over machine application and operation. Proper safety practices are the responsibility of the user and all operating personnel.

**If there is a question on application and/or operation, contact MEC Aerial Work Platforms:**



## MEC Aerial Work Platforms

1401 S. Madera Avenue, Kerman, CA 93630 USA  
Toll Free: 1-877-632-5438  
Phone: 1-559-842-1500  
Fax: 1-559-842-1520  
info@MECawp.com  
www.MECawp.com

## Safety Symbols & General Safety Tips

MEC manuals and decals use symbols, colors and signal words to help you recognize important safety, operation and maintenance information.



**RED** and the word **DANGER** – Indicates an imminently hazardous situation which, if not avoided, will result in death or serious injury.



**ORANGE** and the word **WARNING** – Indicates a potentially hazardous situation which, if not avoided, could result in death or serious injury.



**YELLOW** with alert symbol and the word **CAUTION** – Indicates a potentially hazardous situation which, if not avoided, may result in minor or moderate injury.



**YELLOW** without alert symbol and the word **CAUTION** – Indicates a potentially hazardous situation which, if not avoided, may result in property damage.



**GREEN** and the word **NOTICE** – Indicates operation or maintenance information.

Regular inspection and constant maintenance is the key to efficient economical operation of your aerial work platform. It will help to assure that your equipment will perform satisfactorily with a minimum of service and repair.



The actual operating environment of the machine governs the inspection schedule. Correct lubrication is an essential part of the preventative maintenance to minimize wear on working parts and ensure against premature failure. By maintaining correct lubrication, the possibility of mechanical failure and resulting downtime is reduced to a minimum.

- Never leave hydraulic components or hoses open. They must be protected from contamination (including rain) at all times.
- Never open a hydraulic system when there are contaminants in the air.
- Always clean the surrounding area before opening hydraulic systems.
- Use only recommended lubricants. Improper lubricants or incompatible lubricants may be as harmful as no lubrication.
- Watch for makeshift “fixes” which can jeopardize safety as well as lead to more costly repair.

## Bolt Torque Specification - American Standard

### Fasteners

Use the following values to apply torque unless a specific torque value is called out for the part being used.

American Standard Cap Screws								
SAE Grade	5				8			
Cap Screw Size (Inches)								
	Torque				Torque			
	Ft-lbs		Nm		Ft-lbs		Nm	
	Min	Max	Min	Max	Min	Max	Min	Max
1/4 - 20	6.25	7.25	8.5	10	8.25	9.5	11	13
1/4 - 28	8	9	11	12	10.5	12	14	16
5/16 - 18	14	15	19	20	18.5	20	25	27
5/16 - 24	17.5	19	12	26	23	25	31	34
3/8 - 16	26	28	35	38	35	37	47.5	50
3/8 - 24	31	34	42	46	41	45	55.5	61
7/16 - 14	41	45	55.5	61	55	60	74.5	81
7/16 - 20	51	55	69	74.5	68	75	92	102
1/2 - 13	65	72	88	97.5	86	96	116	130
1/2 - 20	76	84	103	114	102	112	138	152
9/16 - 12	95	105	129	142	127	140	172	190
9/16 - 18	111	123	150	167	148	164	200	222
5/8 - 11	126	139	171	188	168	185	228	251
5/8 - 18	152	168	206	228	203	224	275	304
3/4 - 10	238	262	322	255	318	350	431	474
3/4 - 16	274	302	371	409	365	402	495	544
7/8 - 9	350	386	474	523	466	515	631	698
7/8 - 14	407	448	551	607	543	597	736	809
1 - 8	537	592	728	802	716	790	970	1070
1 - 14	670	740	908	1003	894	987	1211	1137

Torque values apply to fasteners as received from the supplier, dry or when lubricated with normal engine oil.





If special graphite grease, molydisulphide grease, or other extreme pressure lubricants are used, these torque values do not apply.



## Bolt Torque Specification - Metric Standard

### Fasteners

Use the following values to apply torque unless a specific torque value is called out for the part being used.

Metric Cap Screws								
Metric Grade	8.8				10.9			
Cap Screw Size (Millimeters)								
	Torque				Torque			
	Ft-lbs		Nm		Ft-lbs		Nm	
	Min	Max	Min	Max	Min	Max	Min	Max
<b>M6 × 1.00</b>	6	8	8	11	9	11	12	15
<b>M8 × 1.25</b>	16	20	21.5	27	23	27	31	36.5
<b>M10 × 1.50</b>	29	35	39	47	42	52	57	70
<b>M12 × 1.75</b>	52	62	70	84	75	91	102	123
<b>M14 × 2.00</b>	85	103	115	139	120	146	163	198
<b>M16 × 2.50</b>	130	158	176	214	176	216	238	293
<b>M18 × 2.50</b>	172	210	233	284	240	294	325	398
<b>M20 × 2.50</b>	247	301	335	408	343	426	465	577
<b>M22 × 2.50</b>	332	404	450	547	472	576	639	780
<b>M24 × 3.00</b>	423	517	573	700	599	732	812	992
<b>M27 × 3.00</b>	637	779	863	1055	898	1098	1217	1488
<b>M30 × 3.00</b>	872	1066	1181	1444	1224	1496	1658	2027

Torque values apply to fasteners as received from the supplier, dry or when lubricated with normal engine oil.

If special graphite grease, molydisulphide grease, or other extreme pressure lubricants are used, these torque values do not apply.

## Hydraulic Components Torque Table

**Note:** Always lubricate threads with clean hydraulic fluid prior to installation.

Use the following values to torque hydraulic components when a specific value is not available. Always check for torque values in the following places before relying on the Hydraulic Components Torque Table.

- Parts drawings and service instructions in this manual.
- Packaging and instruction sheets provided with new parts.
- Instruction manuals provided by the manufacturer of the component being serviced.

SAE Port Series	Cartridge Poppet		Fittings		Hoses	
	Ft-lbs	Nm	Ft-lbs	Nm	In-lbs	Nm
#4	N/A	N/A	N/A	N/A	135 - 145	15 - 16
#6	N/A	N/A	10 - 20	14 - 27	215 - 245	24 - 28
#8	25 - 30	31 - 41	25 - 30	34 - 41	430 - 470	49 - 53
#10	35 - 40	47 - 54	35 - 40	47 - 54	680 - 750	77 - 85
#12	85 - 90	115 - 122	85 - 90	115 - 122	950 - 1050	107 - 119
#16	130 - 140	176 - 190	130 - 140	176 - 190	1300 - 1368	147 - 155

## Specifications

Maximum Working Height*	Indoor	19 feet	6 meters
	Outdoor	16 feet	4.9 meters
Maximum Platform Height	Indoor	13 feet	3.9 meters
	Outdoor	10 feet	3 meters
Maximum Drive Height		13 feet	4 meters
Stowed Height	Top Guardrail	74 inches	1.9 meters
	Platform Floor	35 inches	0.9 meters
Guardrail Height		39 inches	1 meters
Maximum Occupants	Indoor	2 Person	
	Outdoor	1 Person	
Manual Force	Indoor	90lbs	400N
	Outdoor	45lbs	200N
Toeboard Height		6 inches	15 centimeters
Machine Weight** (Unloaded)		2,050lbs	930kg
Maximum Lift Capacity		500lbs	227kg
Deck Extension Capacity		1 Person	
Length-Stowed	Overall	58 inches	1.5 meters
	Ladder Removed	51 inches	1.3 meters
Platform Length	Extended	75 inches	1.9 meters
	Retracted	51 inches	1.3 meters
Width (Overall)		30 inches	76 centimeters
Platform Width (Outside)		27.5 inches	70 centimeters
Wheel Base		41 inches	1 meter
Turning Radius - Inside		18 inches	45 centimeters
Ground Clearance	Stowed	2.5 inches	6 centimeters
	Elevated	0.6 inches	1.5 centimeters
Drive Speed (Proportional)	Stowed	0-2.5mph	0-4.0km/h
	Raised/Extended	0-0.7mph	0-1.1km/h
Gradability		25% (14°)	
Maximum Side Slope - Stowed		5°	
Ground Pressure/Wheel		112psi	7.9kg/cm <sup>2</sup>
Maximum Wheel Load		750lbs	340kg
Occupied Floor Pressure		234psf	1,138kg/m <sup>2</sup>
Maximum Operating Wind Speed		28mph	12.5 m/sec (45 km/h)
Tire Size		9x3 inch	230x80mm
Lug Nut Torque		19 ft-lb (25.5Nm), secured with cotter pin	
Hydraulic Pressure		2,250 psi	155 bar
Power System Voltage		24 Volt DC	
Battery Charger	Input	110-230 V AC, 50-60 Hz	
	Output	24 Volt DC	
Batteries		Two 12-Volt deep cycle; 85Ah	
Chassis Inclination		1.5 Side , 3.0 Inline	
Meets requirements of ANSI A92.20-2020 and CSA B354.6-2019.			
*Working Height adds 6 feet (2 meters) to platform height.			
**Weight may increase with certain options.			

## Maintenance Lock

### DEATH OR SERIOUS INJURY HAZARD!

**WARNING**

**NEVER PERFORM WORK OR INSPECTION ON THE MACHINE WITH THE PLATFORM ELEVATED WITHOUT FIRST BLOCKING THE SCISSOR ASSEMBLY WITH THE MAINTENANCE LOCK.**

1. Raise the platform approximately 7.2 feet (2.2 meters) from the ground.
2. Rotate the Maintenance Lock away from the machine and let it hang down.
3. Lower the platform until the Maintenance Lock rests securely on the link. Keep clear of the Maintenance Lock when lowering the platform.

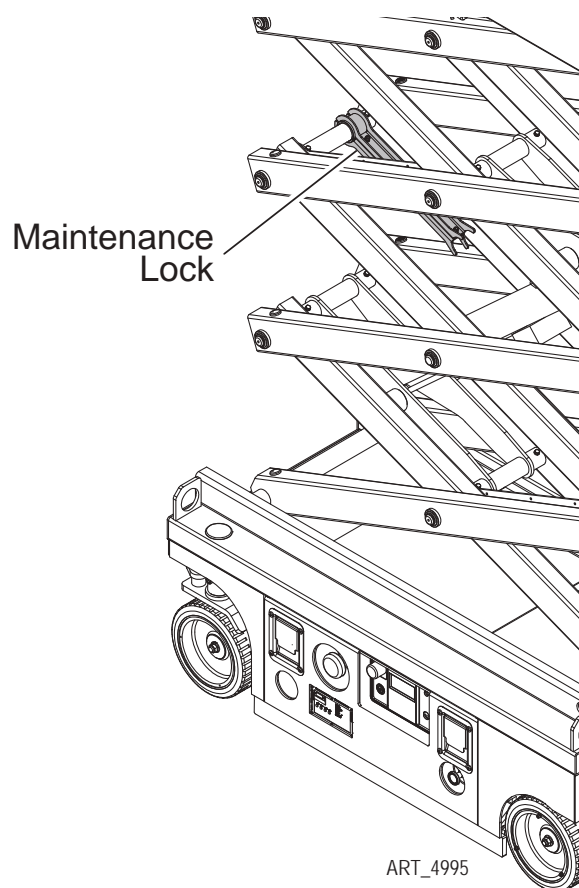

# Machine Systems

## Hydraulic System

---

**WARNING**

**HYDRAULIC FLUID UNDER PRESSURE CAN PENETRATE AND BURN SKIN, DAMAGE EYES, AND MAY CAUSE SERIOUS INJURY, BLINDNESS, AND EVEN DEATH.**

**CORRECT LEAKS IMMEDIATELY.**

---

**CAUTION**

**Hydraulic fluid leaks under pressure may not always be visible. Check for pin hole leaks with a piece of cardboard, not your hand.**

---

## Electrical System

---

**CAUTION**

**Prevent damage to battery and/or electrical system;**

- **Always disconnect the negative battery cable first.**
  - **Always connect the positive battery cable first.**
- 

When the negative cable is installed, a spark will occur if contact is made between the positive side of the battery and a metal surface on the machine. This can cause damage to the electrical system, battery explosion, and personal injury.

## Total System

---

**FAILURE TO PERFORM PREVENTIVE MAINTENANCE AT RECOMMENDED INTERVALS MAY RESULT IN THE UNIT BEING OPERATED WITH A DEFECT THAT COULD RESULT IN INJURY OR DEATH OF THE OPERATOR.**

**WARNING**

**IMMEDIATELY REPORT TO YOUR SUPERVISOR ANY DEFECT OR MALFUNCTION. ANY DEFECT SHALL BE REPAIRED PRIOR TO CONTINUED USE OF THE AERIAL WORK PLATFORM.**

**INSPECTION AND MAINTENANCE SHOULD BE PERFORMED BY QUALIFIED PERSONNEL FAMILIAR WITH THE EQUIPMENT.**

---

# Primary Machine Components

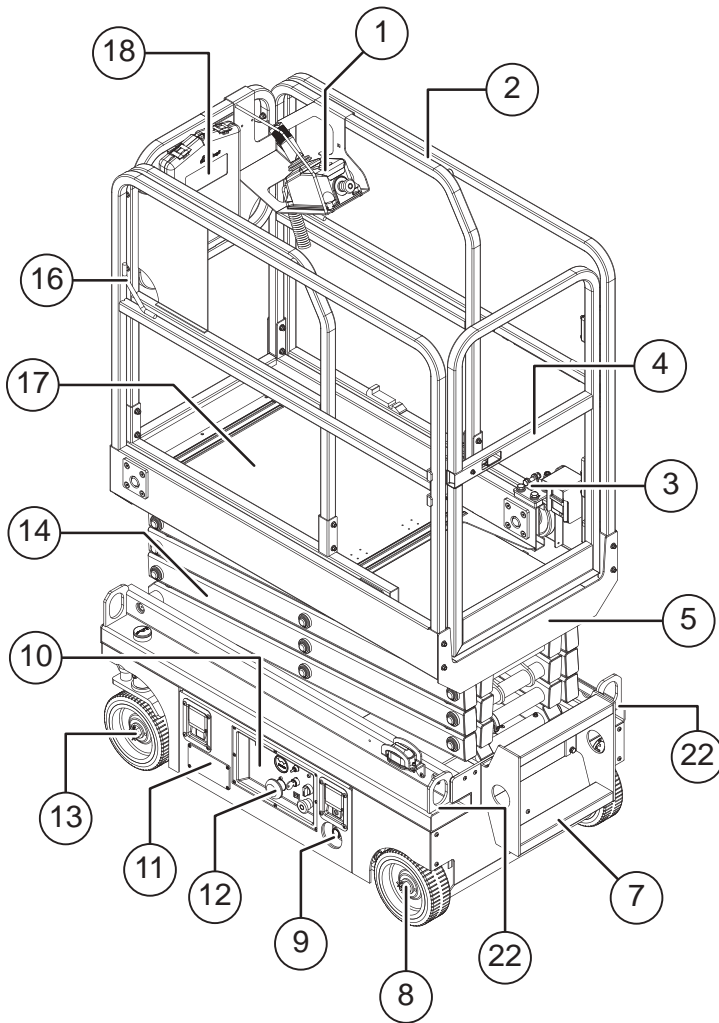

Lift Cylinder and Maintenance Lock shown for visual reference.

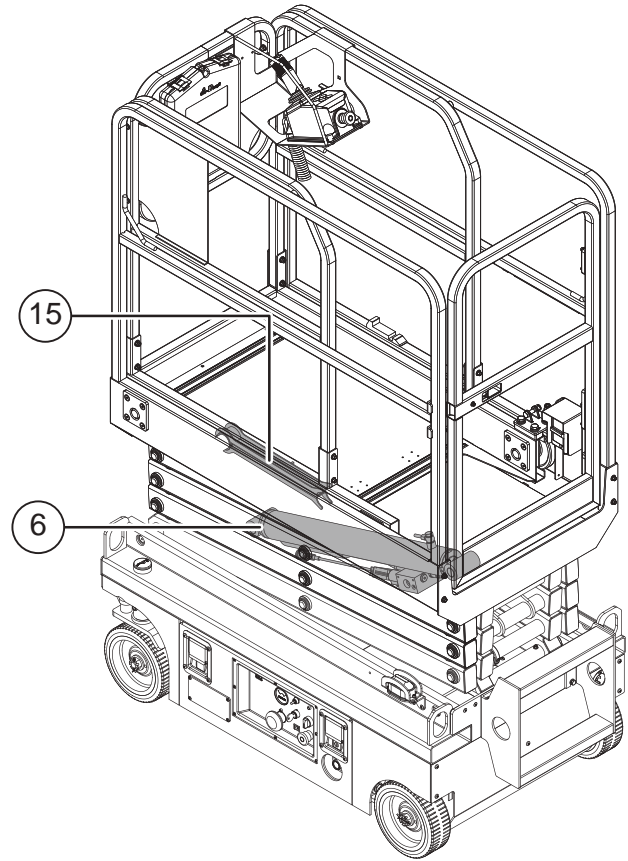

## Control Module

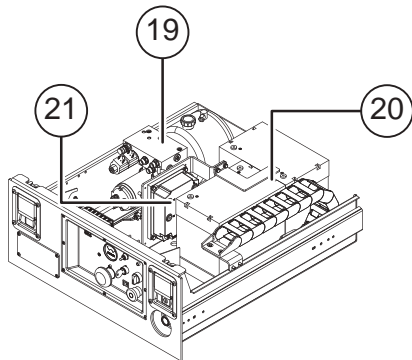

- 1) Platform Controller
- 2) Platform Guard Rails
- 3) Platform Extension Release Pedal
- 4) Platform Entry Gate
- 5) Main Platform
- 6) Lift Cylinder
- 7) Entry Ladder
- 8) Drive Wheels
- 9) Emergency Lowering Knob
- 10) Ground Control Panel
- 11) Battery Charger
- 12) Main Power Switch/Lower Emergency Stop
- 13) Steer Wheels
- 14) Scissor
- 15) Safety Arm
- 16) Lanyard Anchorage Point
- 17) Platform Extension
- 18) Manual Storage Container
- 19) Hydraulic Pump
- 20) Batteries
- 21) Motor Controller
- 22) Forklift Pockets/Tie-Down Points

## Emergency Systems and Procedures



**IF THE CONTROL SYSTEM FAILS WHILE THE PLATFORM IS ELEVATED, HAVE AN EXPERIENCED OPERATOR USE THE EMERGENCY LOWERING PROCEDURE TO SAFELY LOWER THE PLATFORM.**

**DO NOT ATTEMPT TO CLIMB DOWN ELEVATING ASSEMBLY.**

### Emergency Stop

The machine is equipped with an EMERGENCY STOP switch at the base controls and the platform control box.

- Press the EMERGENCY STOP switch at any time to stop all machine functions.
- Pull switch to reset.
- Either switch will stop all machine functions.
- Both switches must be reset or machine will not operate.



ART\_3353

### Emergency Lowering



**IF THE CONTROL SYSTEM FAILS WHILE THE PLATFORM IS ELEVATED, USE THE EMERGENCY LOWERING PROCEDURE TO SAFELY LOWER THE PLATFORM.**

**DO NOT CLIMB DOWN THE ELEVATING ASSEMBLY OR EXIT THE PLATFORM.**

The Emergency Lowering System is used to lower the platform in case of power failure.

To lower the platform, pull the Emergency Lowering Knob, located near the Base Control panel.



ILLUSTRATION No.  
ART\_6272

## Free-Wheel Configuration for Winching or Towing

### RUNAWAY HAZARD!



**AFTER RELEASING THE BRAKES THERE IS NOTHING TO STOP MACHINE TRAVEL. MACHINE WILL ROLL FREELY ON SLOPES.**

**ALWAYS CHOCK THE WHEELS BEFORE MANUALLY RELEASING THE BRAKES.**

The machine can be winched or towed short distances at speeds not to exceed 2.5mph (4km/h). Before towing or winching the machine, it is necessary to release the brakes. Reset the brakes after towing or winching.

### Disengage Brakes Before Towing Or Winching

1. Chock the wheels.
2. Turn the Key Switch to the Off position (pushed in).
3. Pull the Red Emergency Stop button out to the On position (pulled out) at both the ground and platform controls.
4. At the Ground Controls panel, push and hold the red rocker switch to the left & push down and hold the Platform Lift Switch.
5. An alarm will sound, signaling that the brakes have been released.

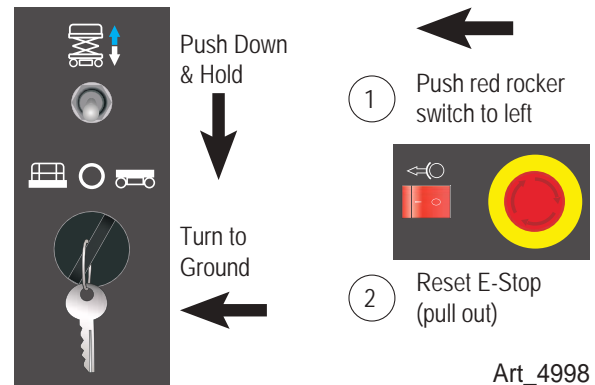

### Resetting Brakes

Push in the Emergency Stop button or turn the Key Switch to the Off position to reset the brakes.



**BE SURE THAT THE BRAKES ARE ENGAGED BEFORE REMOVING THE WHEEL CHOCKS.**



## Lift and Support the Machine



**DEATH OR SERIOUS PERSONAL INJURY MAY RESULT FROM THE USE OF SUBSTANDARD LIFTING DEVICES AND/OR JACK STANDS. ENSURE THAT ALL LIFTING DEVICES AND JACK STANDS ARE OF ADEQUATE CAPACITY AND IN GOOD WORKING CONDITION BEFORE USE.**

The following are needed to safely lift and support the machine;

- A jack with a lifting capacity of two (2) tons or more.
- Jack stands with a rating of two (2) tons or more.

### To Raise the Machine

1. Move machine to a firm level surface capable of supporting the weight of the machine.
2. Chock tires on one end of machine and raise the other end of machine.
3. Position a jack at the end of the machine to be lifted, under a solid lifting point in the center of the frame.
4. Raise the machine and place two (2) suitable jack stands under solid support points at the outer ends of the frame.
5. Lower the machine to rest on the jack stands and inspect for stability.

### To Lower the Machine

1. Raise machine slightly and remove jack stands.
2. Lower the machine and remove the jack.
3. Remove chocks.

## Maintenance

Instructions in this portion of the manual are to be used in conjunction with the Pre-Start, Frequent and Annual Inspection checklists found in this machine's Operator's Manual.

**IMPORTANT:** Scheduled maintenance inspection checklists are included in the Operator's Manual for use only by qualified service technicians. Only qualified service technicians may perform repairs to the machine. After repairs are completed, the operator must perform a Pre-Start Inspection before proceeding to the Functions Test.



**HYDRAULIC FLUID UNDER PRESSURE CAN PENETRATE AND BURN SKIN, DAMAGE EYES, AND MAY CAUSE SERIOUS INJURY, BLINDNESS, AND DEATH. REPAIR LEAKS IMMEDIATELY. FLUID LEAKS UNDER PRESSURE MAY NOT ALWAYS BE VISIBLE. CHECK FOR PIN HOLE LEAKS WITH A PIECE OF CARDBOARD, NOT YOUR HAND.**



**NEVER PERFORM WORK OR INSPECTION ON THE MACHINE WITH THE PLATFORM ELEVATED WITHOUT FIRST BLOCKING THE SCISSOR ASSEMBLY WITH THE MAINTENANCE LOCK (SEE THE INTRODUCTION PORTION OF THIS MANUAL).**

**PERFORM SCHEDULED MAINTENANCE AT RECOMMENDED INTERVALS. FAILURE TO PERFORM SCHEDULED MAINTENANCE AT RECOMMENDED INTERVALS MAY RESULT IN A DEFECTIVE OR MALFUNCTIONING MACHINE AND MAY RESULT IN INJURY OR DEATH OF THE OPERATOR. KEEP MAINTENANCE RECORDS CURRENT AND ACCURATE.**

**IMMEDIATELY REPORT ANY DAMAGE, DEFECT, UNAUTHORIZED MODIFICATION OR MALFUNCTION TO YOUR SUPERVISOR. ANY DEFECT MUST BE REPAIRED PRIOR TO CONTINUED USE. DO NOT USE A DAMAGED, MODIFIED OR MALFUNCTIONING MACHINE.**

**Never leave hydraulic components or hoses open. Plug all hoses and fitting immediately after disassembly to protect the system from outside contamination (including rain).**

**Never open a hydraulic system when there are contaminants in the air.**



**Always clean the surrounding area before opening hydraulic systems.**

**Use only recommended lubricants. Improper lubricants or incompatible lubricants may cause as much damage as no lubrication.**

**Watch for makeshift "fixes" which can jeopardize safety as well as lead to more costly repair.**



Inspection and maintenance should be performed by qualified personnel familiar with the equipment.

### 30-Day Service

Items on this checklist should be inspected before each work shift. Refer to the Operator's Manual.

The 30 day maintenance procedure is a **one-time** procedure to be performed after the first 30 days or 40 hours of usage.

Maintaining the tires and wheels in good condition is essential to safe operation and good performance. Tire and/or wheel failure could result in a machine tip-over. Component damage may also result if problems are not discovered and repaired in a timely fashion.

1. Check the tire surface and sidewalls for cuts, cracks, punctures and unusual wear.
2. Check each wheel for damage, bends and cracks.
3. Remove the wheel covers and check each center lock nut for proper torque and presence of cotter pin.

<b>Front</b>	
Castle Nut Torque, Dry	166.7 ft-lbs (226 Nm)
Castle Nut Torque, Lubricated	125.4 ft-lbs (170 Nm)

<b>Back</b>	
Locknut	100ft-lbs (135 Nm)

## Pre-Start Inspection Checklist

The operator must conduct a Pre-Start Inspection of the machine before each work shift.

DO NOT use a damaged or malfunctioning machine.

	Be sure that the operator's manual are complete, legible and in the storage container located in the platform.
	Be sure that all decals are legible and in place. See Decals section.
	Check for hydraulic oil leaks.
	Check for battery fluid leaks.

**Check the following components or areas for damage, improperly installed or missing parts and unauthorized modifications:**

	Electrical components, wiring and electrical cables
	Battery connections
	Hydraulic hoses, fittings, cylinders and manifolds
	Battery pack and connections
	Drive motors
	Slide blocks/wear pads
	Tires and wheels
	Ground strap
	Limit switches, alarm and beacon
	Nuts, bolts and other fasteners
	Platform entry gate
	Beacons and alarms
	Maintenance Lock
	Platform extension
	Scissor pins and retaining fasteners
	Platform control joystick
	Brake release components
	Pothole guards

**Check entire machine for:**

	Cracks in welds or structural components
	Dents or damage to machine
	Be sure that all structural and other critical components are present and all associated fasteners and pins are in place and properly tightened
	Be sure that guard rails are properly installed and secured, and that all pins and bolts are properly fastened.
	Be sure that the chassis trays are closed and latched and the batteries are properly connected.



**NEVER perform work or inspection on the machine with the platform elevated without first blocking the scissor assembly with the Maintenance Lock. See page 8 for instructions.**

## Frequent Inspection Checklist



**THIS CHECKLIST MUST BE USED AT 3-MONTH INTERVALS OR EVERY 150 HOURS OF MACHINE USE, WHICHEVER OCCURS FIRST. FAILURE TO DO SO COULD RESULT IN DEATH OR SERIOUS INJURY.**

Frequent Maintenance Inspections should be conducted by qualified service technicians only. Photocopy the Frequent Inspection Checklist page from the Operator's Manual to keep record of this inspection. Keep inspections records up to date. Record and report all discrepancies to your supervisor.

Perform all checks listed on Pre-Start Inspection, then proceed with the following checks.

### Hydraulic Fluid

Inspect the condition of hydraulic fluid in the reservoir. Oil should be a clear and amber in color.

### Batteries

Proper battery condition is essential to good machine performance and operational safety. Improper or damaged cables and connections can result in component damage and hazardous conditions.

**ELECTROCUTION / BURN HAZARD. CONTACT WITH ELECTRICALLY CHARGED CIRCUITS COULD RESULT IN DEATH OR SERIOUS INJURY.**



**REMOVE ALL RINGS, WATCHES AND OTHER JEWELRY.**

**BODILY INJURY HAZARD. BATTERIES CONTAIN ACID. AVOID SPILLING OR CONTACTING BATTERY ACID. NEUTRALIZE BATTERY ACID SPILLS WITH BAKING SODA AND WATER.**

1. Put on protective clothing and eye wear.
2. Slide out the component tray from the chassis.
3. Be sure that the battery cable connections are free of corrosion.

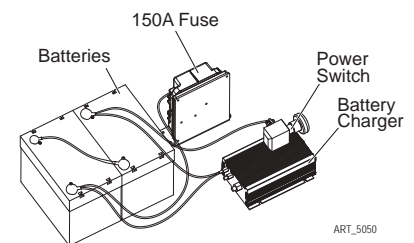

**Note:** Adding terminal protectors and a corrosion preventative sealant will help eliminate corrosion on the battery terminals and cables.

4. Be sure that the battery retainers and cable connections are tight.
5. Fully charge the batteries. Allow the batteries to rest 24 hours before performing this procedure to allow the battery cells to equalize.
6. Check each battery pack and verify that the batteries are wired correctly.
7. Inspect the battery charger plug and pigtail for damage or excessive insulation wear. Replace as required.
8. Connect the battery charger to a properly grounded 110-230V (50-60 Hz) single phase AC

power supply.

- **Result:** The charger should operate and begin charging the batteries.
- **Result:** If, simultaneously, the charger alarm sounds and the LEDs blink, correct the charger connections at the fuse and battery. The charger will then operate correctly and begin charging the batteries.

**Note:** For best results, use an extension cord of adequate size with a length no longer than 50 feet (15 meters).

**Note:** If you have any further questions regarding the battery charger operation, please contact the MEC Customer Service.

## Electrical Wiring

Maintaining electrical wiring in good condition is essential to safe operation and good machine performance. Failure to find and replace burnt, chafed, corroded or pinched wires could result in unsafe operating conditions and may cause component damage.



**ELECTROCUTION / BURN HAZARD. CONTACT WITH ELECTRICALLY CHARGED CIRCUITS COULD RESULT IN DEATH OR SERIOUS INJURY.**

**REMOVE ALL RINGS, WATCHES AND OTHER JEWELRY.**

1. Inspect the following areas for burnt, chafed, corroded and loose wires:
  - Ground Control Panel
  - Hydraulic Power Unit Module Tray
  - Platform Controls
2. Turn the key switch to ground control and pull the red Emergency Stop button out to the On position (pulled out) at both the ground and platform controls
3. Raise the platform approximately 7.2 feet (2.2 meters) from the ground.
4. Lift the safety arm, move it to the center of the scissor arm and rotate up to a vertical position.
5. Lower the platform onto the safety arm.



**CRUSHING HAZARD. KEEP HANDS CLEAR OF THE SAFETY ARM WHEN LOWERING THE PLATFORM.**

6. Inspect the center chassis area and scissor arms for burnt, chafed and pinched cables.
7. Inspect the following areas for burnt, chafed, corroded, pinched and loose wires:
  - Scissor Arms
  - ECU to Platform Controls
  - Power to Platform Wiring
8. Inspect for a liberal coating of dielectric grease in the following locations:
  - Between the ECU and platform controls
  - All wire harness connectors Level sensor
9. Raise the platform and return the safety arm to the stowed position.
10. Lower the platform to the stowed position and turn the machine off.

## Tires and Wheels

Maintaining the tires and wheels in good condition is essential to safe operation and good performance. Tire and/or wheel failure could result in a machine tip-over. Component damage may also result if problems are not discovered and repaired in a timely fashion.

- Check the tire surface and sidewalls for cuts, cracks, punctures and unusual wear.
- Check each wheel for damage, bends and cracks.
- Remove the wheel covers and check each center lock nut for proper torque and presence of cotter pin.

Front	
Castle Nut Torque, Dry	19 ft-lbs (26 Nm)
Castle Nut Torque, Lubricated	14 ft-lbs (20 Nm)

## Emergency Stop

A properly functioning Emergency Stop system is essential for safe machine operation. An improperly operating red Emergency Stop button will fail to shut off power and stop all machine functions, resulting in a hazardous situation.

As a safety feature, selecting and operating from the ground controls will override all platform controls except the platform red Emergency Stop button.

1. Turn the key switch to ground control and pull the red Emergency Stop button out to the On position (pulled out) at both the ground and platform controls.
2. Push in the red Emergency Stop button at the ground controls to the Off position (pushed in).
  - **Result:** No machine functions should operate.
3. Turn the key switch to platform control and pull the red Emergency Stop button out to the On position (pulled out) at both the ground and platform controls.
4. Push in the red Emergency Stop button at the platform controls to the Off position (pushed in).
  - **Result:** No machine functions should operate.

**Note:** The red Emergency Stop button at the ground controls will stop all machine operation, even if the key switch is switched to platform control.

## Key Switch

Proper key switch action and response is essential to safe machine operation. The machine can be operated from the ground or platform controls and the activation of one or the other is accomplished with the key switch. Failure of the key switch to activate the appropriate control panel could cause a hazardous operating situation.

Perform this procedure from the ground using the platform controls. Do not stand in the platform.

1. Pull the red Emergency Stop button out to the On position (pulled out) at both the ground and platform controls.
2. Turn the key switch to platform control.
3. Check the platform up/down function from the ground controls.
  - **Result:** The machine functions should not operate.
4. Turn the key switch to ground control.

5. Check the machine functions from the platform controls.
  - **Result:** The machine functions should not operate.
6. Turn the key switch to the Off position (pushed in).
  - **Result:** No function should operate.

## Horn

The horn is activated at the platform controls and sounds at the ground as a warning to ground personnel. An improperly functioning horn will prevent the operator from alerting ground personnel of hazards or unsafe conditions.

1. Turn the key switch to platform control and pull the red Emergency Stop button out to the On position (pulled out) at both the ground and platform controls.
2. Push down the horn button at the platform controls.
  - **Result:** The horn should sound.

## Drive Brake

Proper brake action is essential to safe machine operation. The drive brake function should operate smoothly, free of hesitation, jerking and unusual noise. Hydraulically released individual wheel brakes can appear to operate normally when not fully operational.

Perform this procedure with the machine on a firm level surface that is free of obstructions, with the platform extension deck fully retracted and the platform in the stowed position.

1. Mark a test line on the ground for reference.
2. Turn the key switch to platform control and pull the red Emergency Stop button out to the On position (pulled out) at both the ground and platform controls.
3. Press the drive function select button.
4. Choose a point on the machine; i.e., contact patch of a tire, as a visual reference for use when crossing the test line.
5. Bring the machine to top drive speed before reaching the test line. Release the function enable switch or the joystick when your reference point on the machine crosses the test line.
6. Measure the distance between the test line and your machine reference point.
  - **The maximum braking distance at high speed on a paved surface is 24 inches±11.8 inches (61 centimeters±30 centimeters)**
  - **Result:** The machine stops within the specified braking distance. No action required.
  - **Result:** The machine does not stop within the specified braking distance.

**Note:** The brakes must be able to hold the machine on any slope it is able to climb.

7. Replace the brakes and repeat this procedure beginning with step 1.

## Drive Speed, Lowered Platform

Proper drive functions are essential to safe machine operation. The drive function should respond quickly and smoothly to operator control. Drive performance should also be free of hesitation, jerking and unusual noise over the entire proportionally controlled speed range.

Perform this procedure with the machine on a firm, level surface that is free of obstructions.



1. Create start and finish lines by marking two lines on the ground 40 feet (12.2 meters) apart.
2. Turn the key switch to platform control and pull the red Emergency Stop button out to the On position (pulled out) at both the ground and platform controls.
3. Lower the platform to the stowed position.
4. Press the drive function select button.
5. Choose a point on the machine; i.e., contact patch of a tire, as a visual reference for use when crossing the start and finish lines.
6. Bring the machine to top drive speed before reaching the start line. Begin timing when your reference point on the machine crosses the start line.
7. Continue at full speed and note the time when your reference point on the machine passes over the finish line. The time should be 9-11 sec.

### **Drive Speed, Raised Platform**

Proper drive functions are essential to safe machine operation. The drive function should respond quickly and smoothly to operator control. Drive performance should also be free of hesitation, jerking and unusual noise over the entire proportionally controlled speed range.

Perform this procedure with the machine on a firm, level surface that is free of obstructions.

1. Create start and finish lines by marking two lines on the ground 40 feet (12.2 meters) apart.
2. Turn the key switch to platform control and pull the red Emergency Stop button out to the On position (pulled out) at both the ground and platform controls.
3. Press the lift function select button.
4. Press and hold the function enable switch on the joystick.
5. Raise the platform approximately 4 feet (1.2 meters) from the ground.
6. Press the drive function select button.
7. Choose a point on the machine; i.e., contact patch of a tire, as a visual reference for use when crossing the start and finish lines.
8. Bring the machine to top drive speed before reaching the start line. Begin timing when your reference point on the machine crosses the start line.
9. Continue at full speed and note the time when your reference point on the machine passes over the finish line. The time should be 35-40 sec.

### **Drive Speed, Slow**

Proper drive functions are essential to safe machine operation. The drive function should respond quickly and smoothly to operator control. Drive performance should also be free of hesitation, jerking and unusual noise over the entire proportionally controlled speed range.

Perform this procedure with the machine on a firm, level surface that is free of obstructions.

1. Create start and finish lines by marking two lines on the ground 40 feet (12.2 meters) apart.
2. Turn the key switch to platform control and pull the red Emergency Stop button out to the On position (pulled out) at both the ground and platform controls.
3. Lower the platform to the stowed position.
4. Press the slow speed select button.
5. Choose a point on the machine; i.e., contact patch of a tire, as a visual reference for use when crossing the start and finish lines.

6. Bring the machine to top drive speed before reaching the start line. Begin timing when your reference point on the machine crosses the start line.
7. Continue at full speed and note the time when your reference point on the machine passes over the finish line. The time should be 18-22 sec.

## Hydraulic Oil Analysis

Replacement or testing of the hydraulic oil is essential for good machine performance and service life. Dirty oil may cause the machine to perform poorly and continued use may cause component damage. Extremely dirty conditions may require oil changes to be performed more often.

Before replacing the hydraulic oil, the oil may be tested by an oil distributor for specific levels of contamination to verify that changing the oil is necessary.

Hydraulic oil should be tested yearly and replaced if it fails. If the hydraulic oil is not replaced at the Annual Inspection, test the oil quarterly. Replace the oil when it fails the test.

## Tank Venting System

A free-breathing hydraulic tank cap is essential for good machine performance and service life. A dirty or clogged cap may cause the machine to perform poorly. Extremely dirty conditions may require that the cap be inspected more often.

1. Remove the breather cap from the hydraulic tank.
2. Check for proper venting.
  - **Result:** Air passes through the breather cap.
  - **Result:** If air does not pass through the cap, clean or replace the cap. Proceed to step 3.

**Note:** When checking for positive tank cap venting, air should pass freely through the cap.

3. Using a mild solvent, carefully wash the cap venting system. Dry using low pressure compressed air. Repeat step 2.
4. Install the breather cap onto the hydraulic tank.

# Annual Inspection Checklist



**THIS CHECKLIST MUST BE USED AT 12-MONTH INTERVALS OR EVERY 600 HOURS OF MACHINE USE, WHICHEVER OCCURS FIRST. FAILURE TO DO SO COULD RESULT IN DEATH OR SERIOUS INJURY.**

Annual Maintenance Inspections should be conducted by qualified service technicians only. Photocopy the Annual Inspection Checklist page from the Operator's Manual to keep record of this inspection. Keep inspections records up to date. Record and report all discrepancies to your supervisor.

Perform all checks listed on Pre-Start Inspection and the Frequent Inspection, then check all items listed on the Annual Inspection Report. See specific instructions below.

## Scissor Slide Blocks

Maintaining the condition of the scissor arm slide blocks is essential to safe machine operation. Continued use of worn out wear pads may result in component damage and unsafe operating conditions.

Perform this procedure with the platform in the stowed position.

1. Measure the distance between the number one inner arm cross tube and the chassis deck at the ground controls side of the non-steer end of the machine.
  - **Result:** The measurement is 1.18 inches (30 millimeters) or more. Proceed to step 2.
  - **Result:** The measurement is less than 1.18 inches (30 millimeters). Replace both wear pads.
2. Measure the distance between the number one inner arm cross tube and the chassis deck at the battery pack side of the non-steer end of the machine.
  - **Result:** The measurement is 1.18 inches (30 millimeters) or more. Proceed to step 3.
  - **Result:** The measurement is less than 1.18 inches (30 millimeters). Replace both wear pads.
3. Apply a thin layer of dry film lubricant to the area of the chassis where the scissor arm wear pads make contact.

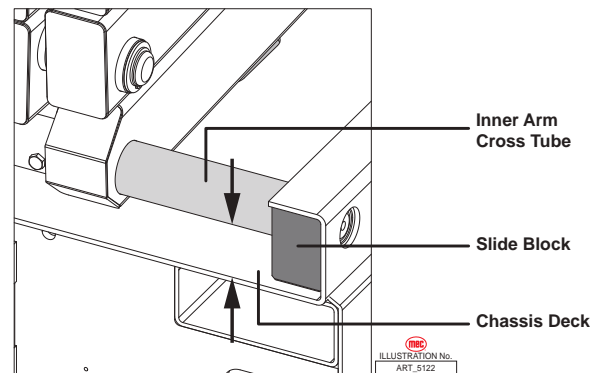

## Hydraulic Tank Breather Cap

The hydraulic tank is a vented-type tank. The breather cap has an internal air filter that can become clogged or, over time, can deteriorate.

If the breather cap is faulty or improperly installed, impurities can enter the hydraulic system which may cause component damage. Extremely dirty conditions may require that the cap be inspected more often.

1. Remove and discard the hydraulic tank breather cap.
2. Install a new cap onto the tank.

## Hydraulic Oil Inspection

Replacement or testing of the hydraulic oil is essential for good machine performance and service life. Dirty oil may cause the machine to perform poorly and continued use may cause component damage. Extremely dirty conditions may require oil changes to be performed more often.

Before replacing the hydraulic oil, the oil may be tested by an oil distributor for specific levels of contamination to verify that changing the oil is necessary.

Hydraulic oil should be tested yearly and replaced if it fails. If the hydraulic oil is not replaced at the Annual Inspection, test the oil quarterly. Replace the oil when it fails the test.

**Note:** Perform this procedure with the platform in the stowed position.

1. Slide out the Component Tray.
2. Disconnect the battery pack from the machine.



**ELECTROCUTION / BURN HAZARD. CONTACT WITH ELECTRICALLY CHARGED CIRCUITS COULD RESULT IN DEATH OR SERIOUS INJURY.**

**REMOVE ALL RINGS, WATCHES AND OTHER JEWELRY.**

3. Tag and disconnect the hydraulic pump outlet line and remove the line from the pump. Cap the fitting on the pump.
4. Loosen the bolts and remove the hydraulic power pack from the tray.
5. Open the oil plug of tank. Drain all of the oil into a suitable container.
6. Loosen and remove the bolts and separate the tank from the pump body.

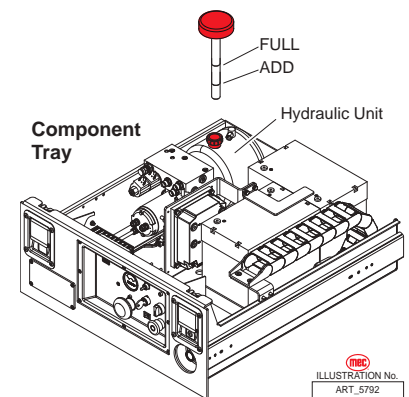

**BODILY INJURY HAZARD. SPRAYING HYDRAULIC OIL CAN PENETRATE AND BURN SKIN. LOOSEN HYDRAULIC CONNECTIONS VERY SLOWLY TO ALLOW THE OIL PRESSURE TO DISSIPATE GRADUALLY. DO NOT ALLOW OIL TO SQUIRT OR SPRAY.**

7. Clean up any oil that may have spilled. Properly discard the used oil.
8. Clean the inside of the hydraulic tank using a mild solvent. Allow the tank to dry completely.
9. Install the hydraulic tank and install and tighten the hydraulic tank retaining fasteners. Torque to specification.
  - Hydraulic Tank Retaining Fasteners, Dry: 35in-lbs (4Nm)
  - Hydraulic Tank Drain Plug, Lubricated: 26in-lbs (3Nm)
10. Install the hydraulic power pack into the component tray. Install the fitting and hydraulic hoses

onto the hydraulic power pack and torque.

11. Fill the tank with hydraulic oil to the middle of the dipstick. Do not overfill.

12. Activate the pump to fill the hydraulic system with oil and bleed the system of air.



**COMPONENT DAMAGE HAZARD. THE PUMP CAN BE DAMAGED IF OPERATED WITHOUT OIL. BE CAREFUL NOT TO EMPTY THE HYDRAULIC TANK WHILE IN THE PROCESS OF FILLING THE HYDRAULIC SYSTEM. DO NOT ALLOW THE PUMP TO CAVITATE.**

---

# Maintenance Inspection Report

## SE & MICRO Series Scissors

Fleet Equipment Number \_\_\_\_\_ Date \_\_\_\_\_  
 Inspector Name \_\_\_\_\_ Inspector Co. \_\_\_\_\_  
 Model Number \_\_\_\_\_ Address \_\_\_\_\_  
 Serial Number \_\_\_\_\_  
 Hour Meter \_\_\_\_\_ Signature \_\_\_\_\_  
 Machine Owner & address \_\_\_\_\_

**Maintain all service records in accordance with ANSI A92.24-2019**

\* If an inspection receives an "N", remove from service. Once repaired, place an "R" in the box.  
 \* Refer to the proper service manual for specific information, settings and torque specifications.

**Key** Y = Yes, Acceptable N = No, Remove from Service R = Repaired 0 = Not Applicable

**QUARTERLY** - Inspect only those marked "Q"  **ANNUAL** - Inspect all items

	Q/A	Y/N/O	R
<b>DECALS:</b>			
Legible - undamaged/readable	Q		
Capacity decal correct for model	Q		
<b>RAILS:</b>			
Not damaged, all in place	Q		
All rail fasteners secure	Q		
Entry gate secure, closes properly	Q		
Manual box in good condition	Q		
Operators Manual in manual box	Q		
<b>PLATFORM EXTENSION:</b>			
Rolls in and out freely	Q		
Lock holds deck in place	Q		
Release pedal moves freely (lube)	Q		
<b>ELEVATING ASSEMBLY:</b>			
Scissor Slide Blocks, lubed	Q		
Maintenance Stand, good Cond	Q		
Beam structures: Straight, no cracks	A		
Welds: secure, no cracks	A		
Retaining Rings	A		
Cylinder Pins, secure	A		
<b>ELECTRICAL:</b>			
GFCI operates correctly	Q		
Wire harnesses good cond, secure	A		
Comm cable no damage, secure	A		
<b>BASE:</b>			
Fasteners tight	Q		
Cover panels secure	Q		
Welds	A		

	Q/A	Y/N/O	R
<b>WHEELS:</b>			
Tire damage	Q		
Lug nuts (Wheel mounting) torqued correctly	Q		
King Pins lubed	A		
<b>COMPONENT AREA:</b>			
Hydraulic - no leaks	Q		
Hydraulic tank, correct level	Q		
Hoses not damaged - Fittings tight	Q		
Valve manifold secure, no leaks	Q		
Power unit secure, no leaks	Q		
Batteries properly filled and cables clean	Q		
Emergency stop, cuts power/operation	Q		
Battery switch cuts battery feed	Q		
Plastic cover secure (door end 2632-4555 only)	A		
Hydraulic tank, oil clean	A		
Replace Hydraulic Filter (if equipped)	A		
Clean or replace tank breather filter	A		
<b>OPERATIONAL INSPECTION:</b>			
All functions, operate smooth and quiet	Q		
All functions, speeds correct.	Q		
Upper control box, operates correctly	Q		
Emergency Down, operates correctly	Q		
Limit switches slows drive when elevated	Q		
Pothole switch test	Q		
Steering pressure relief, set correctly	Q		
Lift pressure relief, set correctly	Q		
**Check Platform Overload Sensing operation	Q		

\*\*For machine equipped with Platform Overload Protection system only



# Control Component Locations

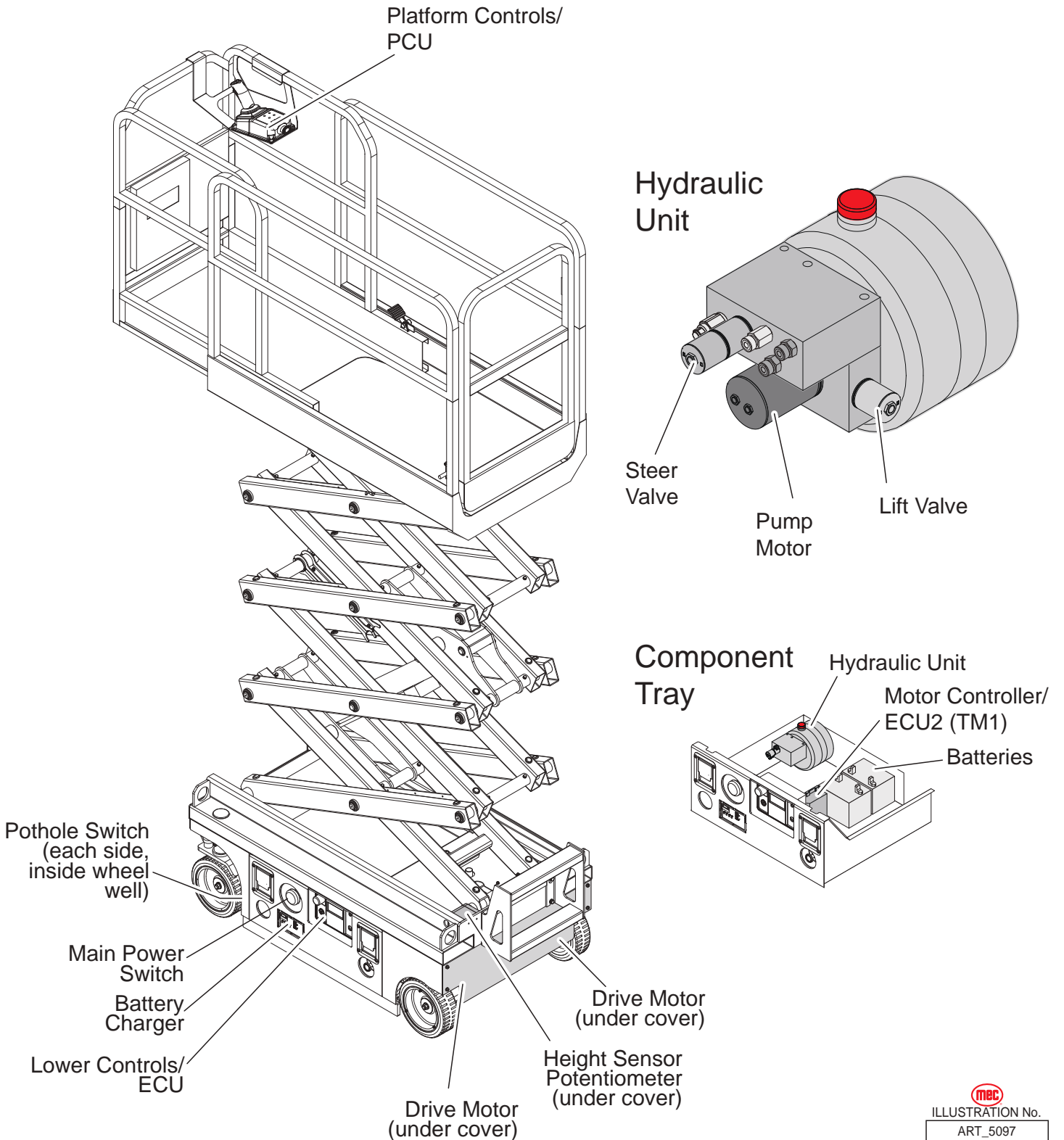
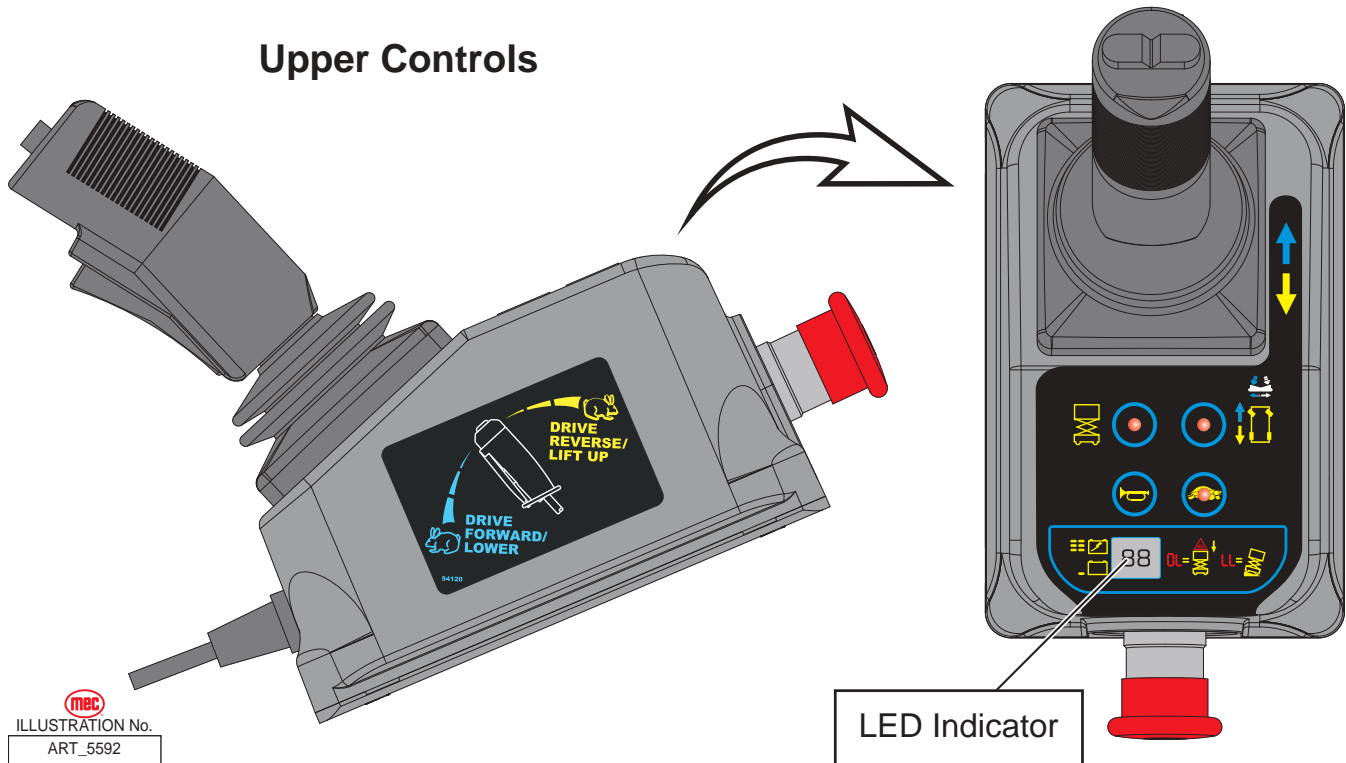

  
ILLUSTRATION No.  
ART\_5097

# Fault Codes

Fault Codes, when present, appear on the LED Indicator at the Upper Controls station and on the LED Screen at the Lower Controls station.

## Upper Controls



## 1330SE Lower Controls

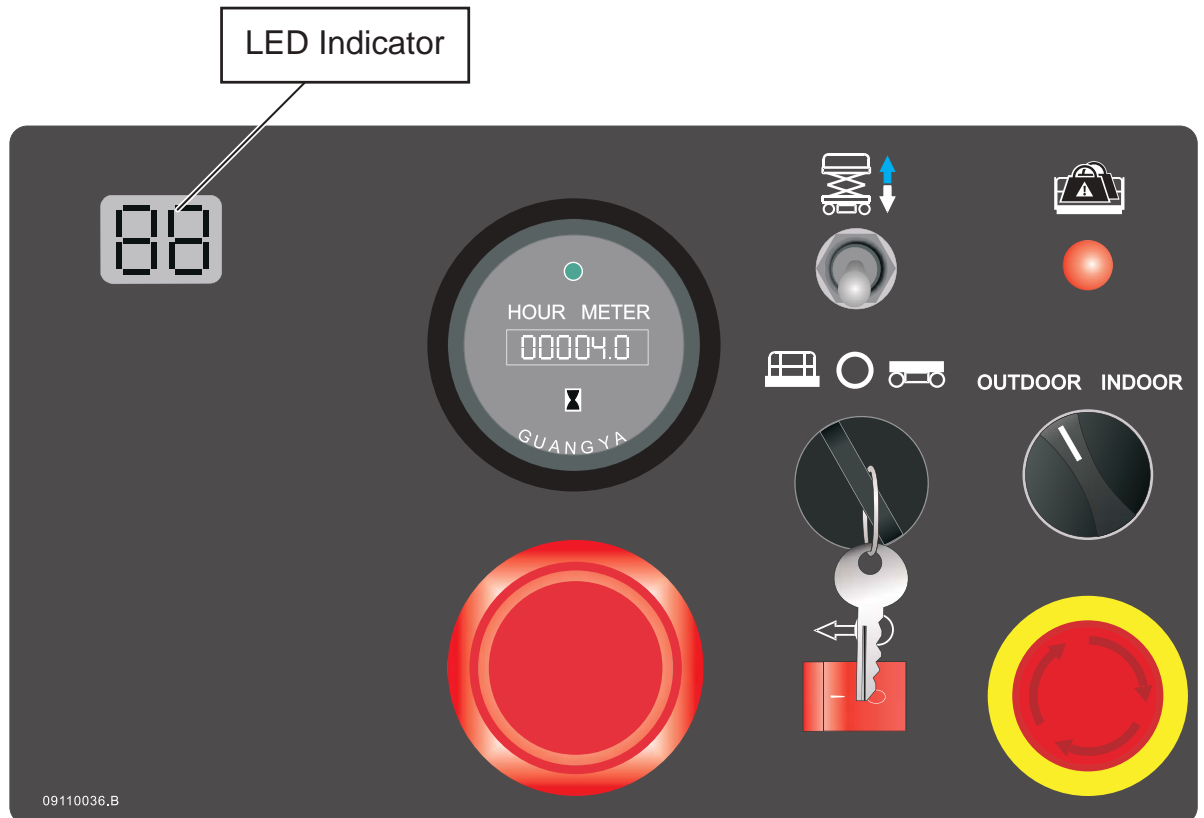



## Error Indicator Readout

If the LED diagnostic readout displays an error code, such as LL, push in and turn the red Emergency Stop button to reset the system.



Art\_5533

Fault	Description	Models	Solutions
01/10	System Initialization Fault	All Models	Check the ECU.
02/20	System Communication Fault	All Models	Check the platform control, wiring on platform connector, ECU, battery, and relay on ground control.
03	Invalid Option Setting	All Models	Reset the option code. See Service manual for instructions.
12	Chassis Up or Down Switch ON at power-up Fault	All Models	Check the wiring on toggle switch, and the toggle switch.
18	Pothole Guard Fault	All Models	Check the pothole board and switches. If stowed, check limit switch.
31	Pressure Sensor Fault	Micro 19	Check option code. See Service manual for instructions.
32	Angle Sensor Fault	All Models > 2020 With Overload	Check wiring to angle sensor for normal voltage range < 2020, 1.9-3.8V, then check the option code.
42	Left turn switch ON at power- up	All Models	Check the left steer button, and the platform controller.
43	Right Turn Switch ON at power-up	All Models	Check the right steer button, and the platform controller.
46	Joystick Enable Switch ON at power-up	All Models	Wait several seconds when turning on the lift, then check the joystick dead-man switch.
47	Joystick not in neutral at power-up	All Models	Check the joystick, and the platform controller.
52	Drive Forward Coil Fault	All Models	Check the option code. See Service manual for instructions.
53	Drive Reverse Coil Fault	All Models	Check the option code. See Service manual for instructions.
54	Lift Up Coil Fault	All Models	Check the lift solenoid and wiring.
55	Lift Down Coil fault	All Models	Check the down solenoid and wiring, and the scissor harness for crushed or pinched wires.
56	Right Turn Coil Fault	All Models	Check the right steering solenoid and wiring.
57	Left Turn Coil Fault	All Models	Check the left steering solenoid and wiring.
58	General Brake Coil Fault - Brakes about 46 ohms	All Models	Check the brake module and wiring, brakes and wiring, and the battery voltage.
60	Motor Controller Fault	All Models	Replace the motor controller.
61	Motor Controller Sensor Fault	All Models	Check the drive motor and wiring, and the drive motor controller and wiring.
62	Motor Controller Hardware Failsafe Fault	All Models	Cycle power, then replace the Motor Controller.
63	Motor Controller Output Fault	All Models	Check the drive motor and wiring for shorts, and the drive motor controller and wiring.
64	Motor Controller SRO Fault	All Models	Replace motor controller

Fault	Description	Models	Solutions
65	Motor Controller Throttle Fault	All Models	Replace motor controller
66	Motor Controller Emergency Reverse Fault	All Models	Replace motor controller
67	Motor Controller HPD Fault	All Models	Replace motor controller, check contactor, replace ECU.
68	Low Voltage Fault	All Models	Check battery voltage and charge batteries if necessary, check battery connections, connection from ECU to PCU, then the voltage to the ECU and PCU.
69	High Neutral Current Fault	All Models	Motor seized - This message comes just before other faults but should be ignored in those cases.
70	Steer Input Out of Range	All Models	Check for loose wires on motor controller, replace motor controller.
71	Motor Controller Main Contactor Fault	All Models	Check wiring to contactor, white and black wire could be off, check drive motor and wiring, and motor controller and wiring. Replace contractor.
72	Motor Controller Over Voltage Fault	All Models	Check battery voltage with battery charger off, cycle power to machine, replace motor controller.
73	Motor Controller Thermal Cutback Fault	All Models	Drive/Lift Motor may be overheating so let motor cool down, cycle power to reset Motor controller, replace motor controller.
74	Motor Controller Motor Fault	All Models	Check connections at motors "motor open", cycle power to the lift, and replace motor controller.
75	Motor Controller Pump Motor Fault	All Models	Check connections to the Pump Motor, cycle power to the lift, and replace motor controller.
76	Motor Controller Left Drive Motor Fault	All Models	Check connections to the motors, cycle power to the lift, and replace motor controller.
77	Motor Controller Right Drive Motor Fault	All Models	Check connections to the motors, cycle power to the lift, and replace motor controller.
78	Pump Motor Short Fault: 0.8-1.4 ohms	All Models	Check connections to the pump motor, cycle power to the lift, and replace motor controller.
79	Left Drive Motor Short Fault	1930SE Only	Check the left drive motor and wiring, and the ZAPI drive controller and wiring.
	(Should be 0.5-2.0 ohms)	Micro 19	Swap wires on drive motors: if code changes it's in wiring or motor and if code doesn't change it's in motor controller.
80	Over 80% Load Warning	All Models	Platform is getting close to limit of weight. > 2020 with overload
81	Right Drive Motor Short	1930SE/Micro	Check the right drive motor and wiring, and motor controller and wiring.
82	Right Brake Coil - Brakes about 46 ohms	1930SE/Micro	Check battery voltage, contactor, wiring to brakes, wiring to drive motors, motor controller and wiring.
		All Models	Check battery voltage, right motor brake and wiring, brake module and wiring, and contactor.

<b>Fault</b>	<b>Description</b>	<b>Models</b>	<b>Solutions</b>
83	Left Brake Coil - Brakes about 46 ohms	1930SE/Micro	Check battery voltage, contactor, wiring on brakes, wiring to drive motors, motor controller and wiring.
		All Models	Check battery voltage, left motor brake and wiring, brake module and wiring, and contactor.
85	Brake Release Switch Closed	1930SE/Micro	Turn brake release switch off. Replace brake release switch.
86	Raised Brake Release Fault	1930SE Only	Brake release switch engaged.
87	Brake Release Switch Fault	1930SE Only	Brake release switch open.
89	Drive Motor Field Open	All Models	Check wiring on motors and motor controller.
91	Left Drive Motor Short	All Models	Check wiring to motor and motor controller.
92	Right Drive Motor Short	All Models	Check wiring to motor and motor controller.
99	Over 99% Load Warning	All Models	Platform has reached its weight capacity.
OL	Platform Overloaded	All Models	Remove the excess load immediately. > 2020 with overload.
LL	Machine Tilted Beyond Safe Limits Fault	All Models	Check to see if machine is tilted, then check wiring to tilt sensor and the tilt sensor.
CH	NOT A FAULT CODE	All Models	Indicates that key switch is in base controls.

# Hydraulic Schematic

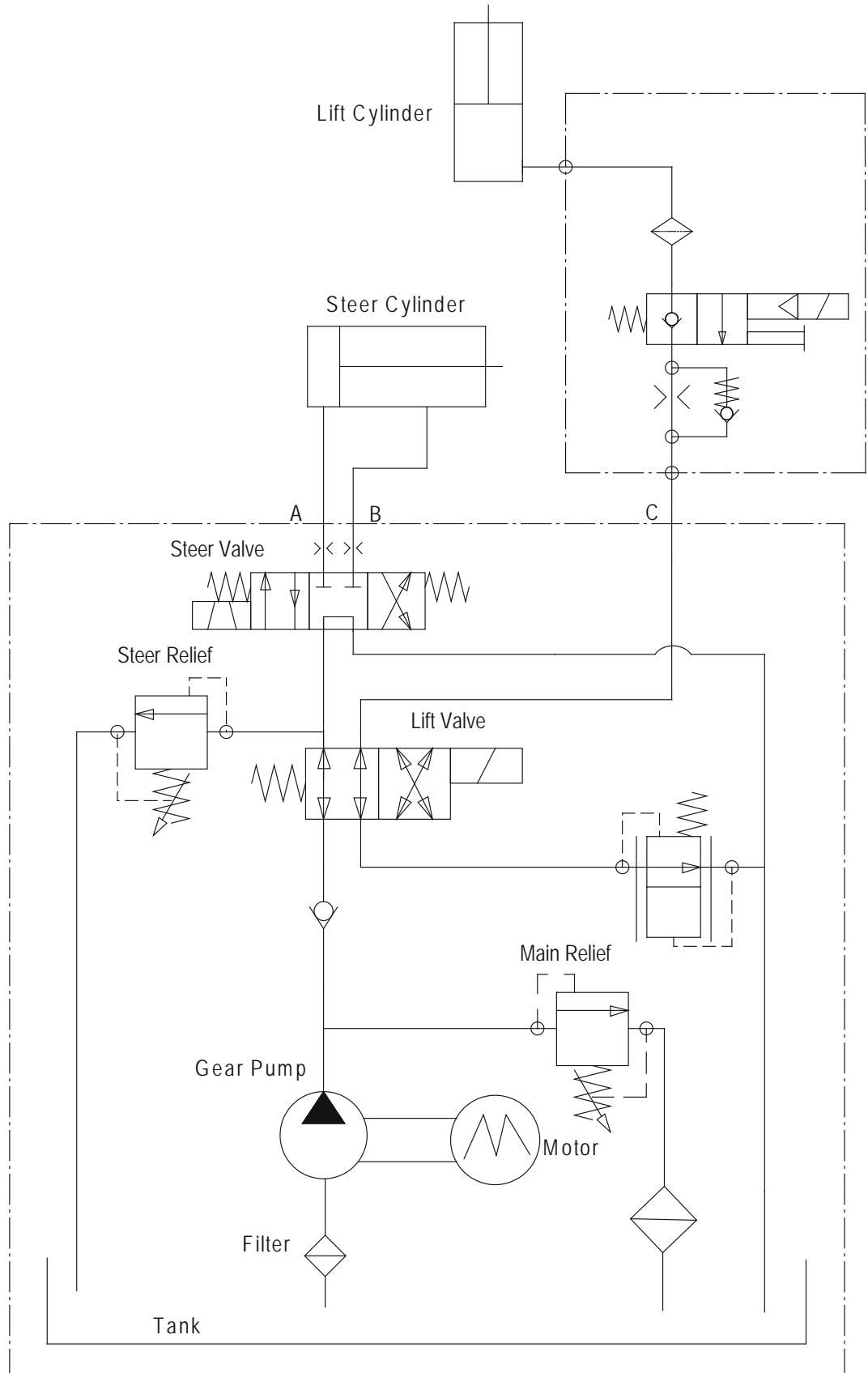

# Hydraulic Unit

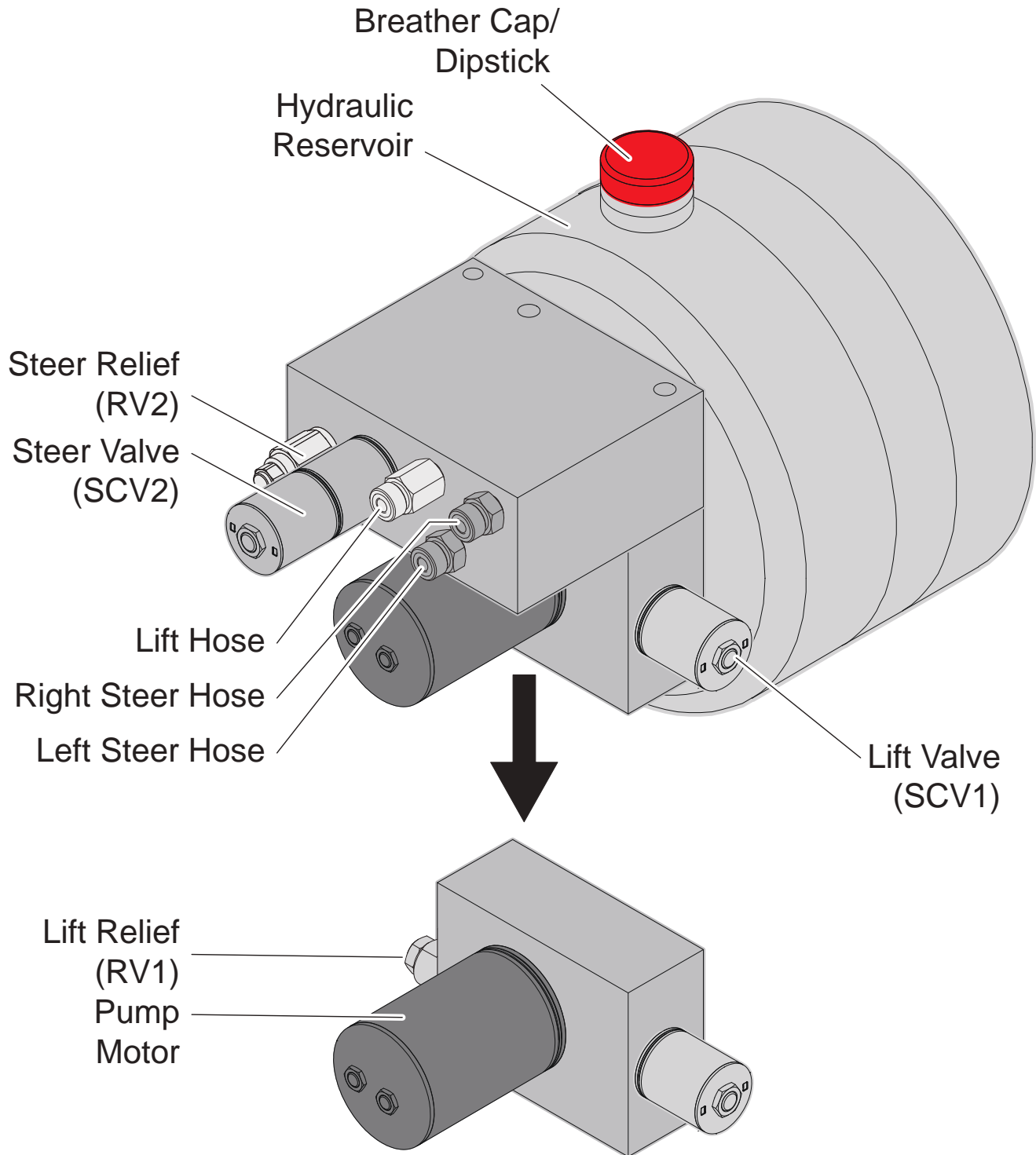

# Electrical Schematic

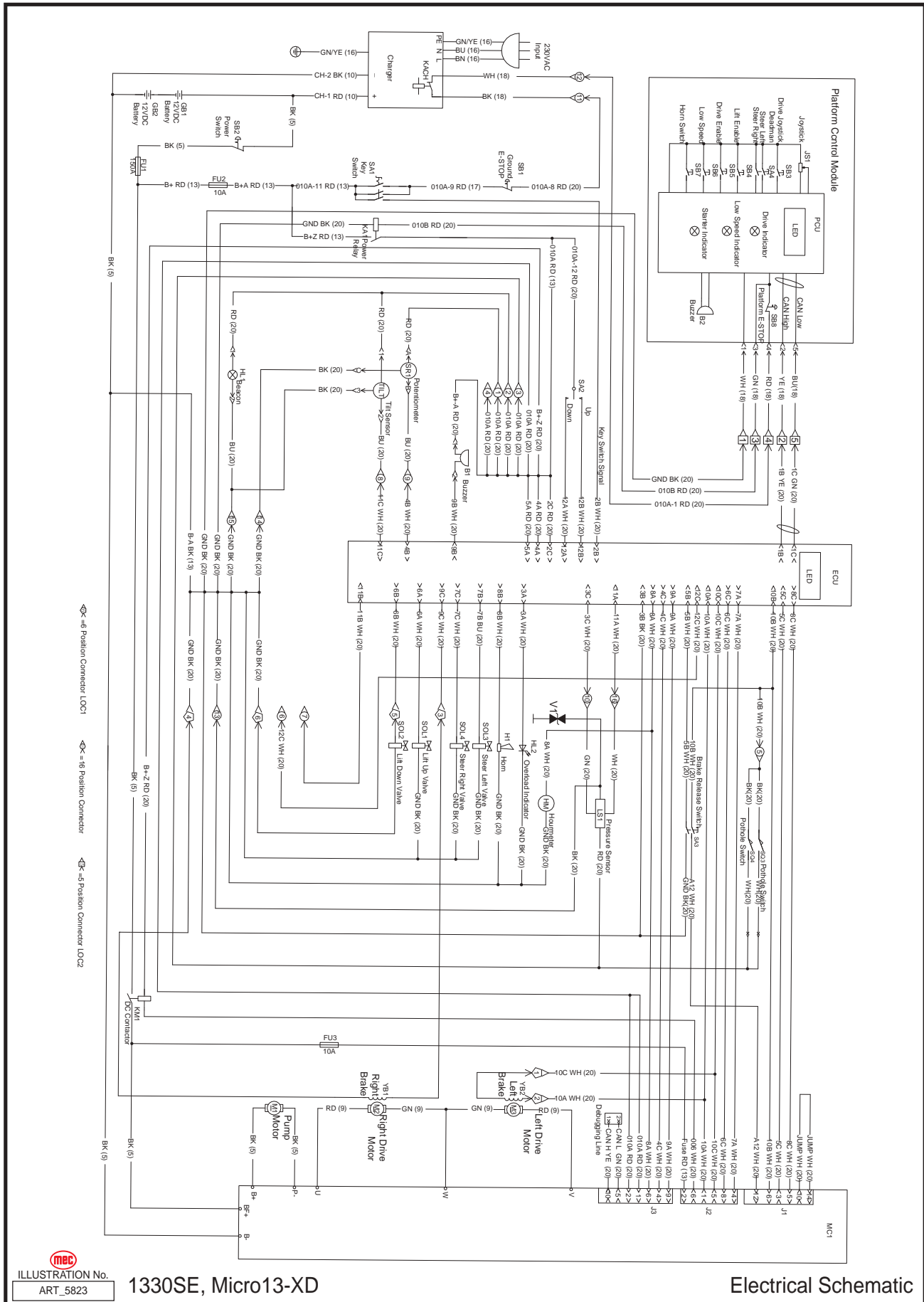

ILLUSTRATION No. ART\_5823

1330SE, Micro13-XD

Electrical Schematic





# Steer Linkage and Wheels Assembly, To Serial #16308570

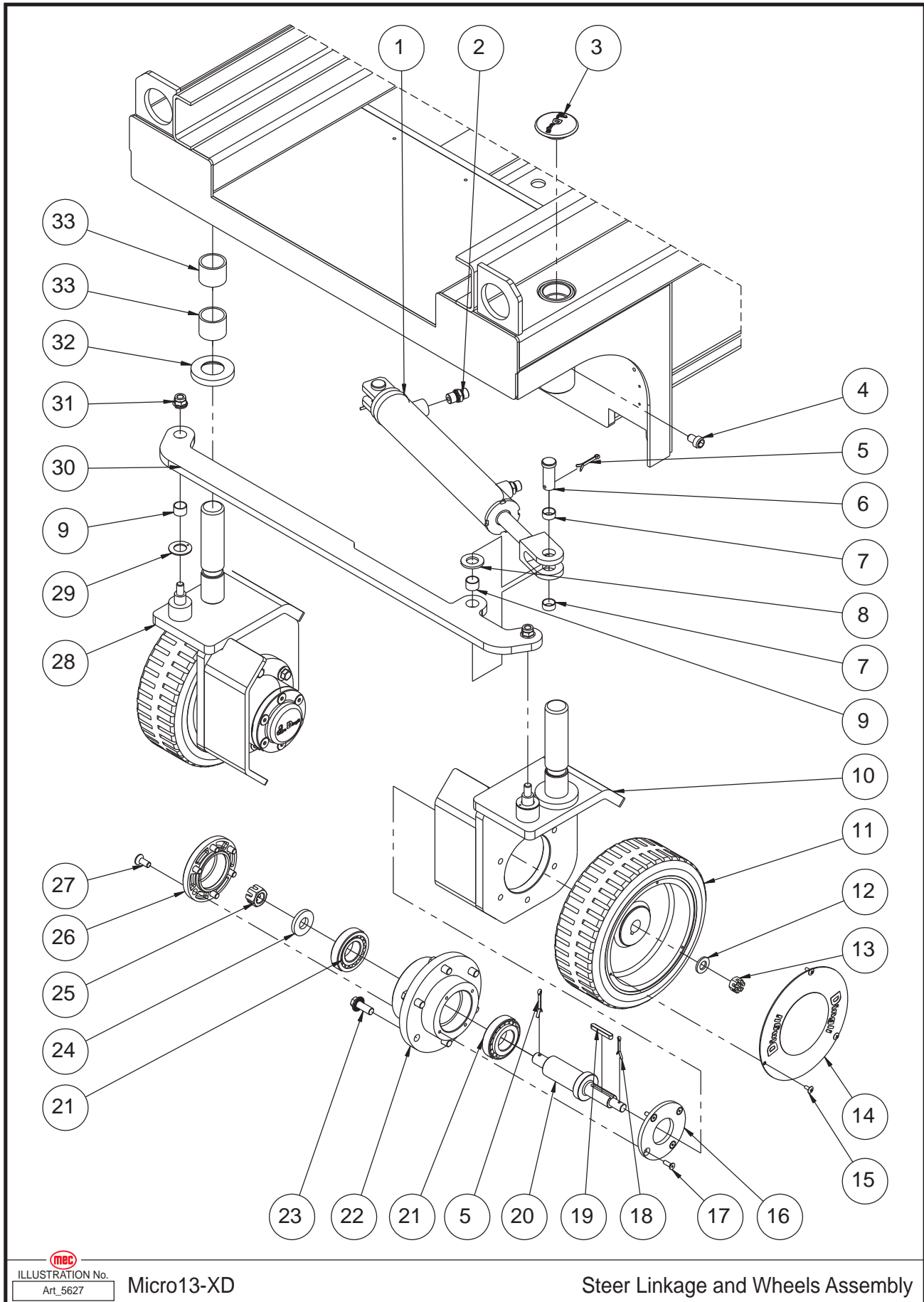

 ILLUSTRATION No. **Micro13-XD**  
Art\_5627

Steer Linkage and Wheels Assembly



Item	Part Number	Description	Qty.
1	41223	Steer Cylinder Assembly	1
--	41594	Seal Kit	1
2	41298	Straight Fitting	2
3	41318	Cover	2
4	41794	Screw	2
5	41322	Cotter Pin	4
6	41321	Pin	2
7	41225	Bearing	4
8	43564	Washer	2
9	41210	Bearing	4
10	44043	Steer Yoke Weldment	1
11	41228	Wheel	2
12	50003	WSHR M12 Standard Flat Washer	2
13	53363	Castle Nut M12-1.75, Hex Thin Slotted	2
14	41323	Cover	2
15	53348	Screw THMS M04-0.70 x 10	6
16	41230	Bearing Cover	2
17	53269	Screw CSCS M05-0.80 x 16	8
18	44493	Cotter Pin	2
19	44029	Key	2
20	41233	Wheel Shaft	2
21	41024	Bearing	4
22	41234	Connection Plate	2
23	50429	Screw HHCS M10-1.50 x 25 Serrated Flange	12
24	41327	Washer	2
25	53347	Castle Nut M16 x 1.50	2
26	41328	Cap	2
27	53282	Screw CSCS M08-1.25 x 20	12
28	44042	Steer Yoke Weldment	1
29	41222	Bearing	2
30	41221	Tie Rod	1
31	50311	Nut NNYL M10-1.50 Flange	2
32	41199	Washer	2
33	41202	Bearing	4

# Steer Linkage and Wheels Assembly, From Serial #16308571

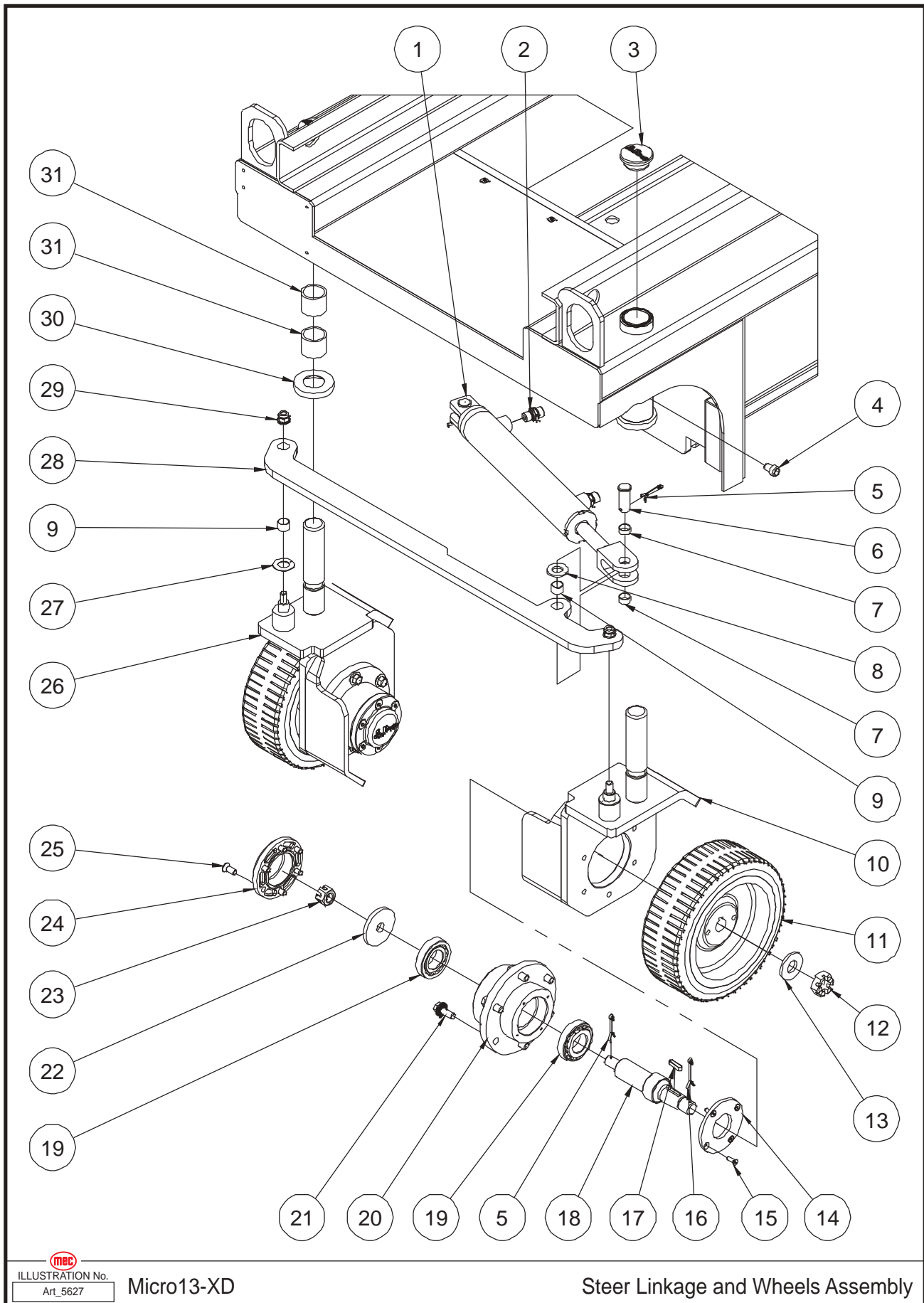

 ILLUSTRATION No. **Micro13-XD**  
Art\_5627

Steer Linkage and Wheels Assembly

Item	Part Number	Description	Qty.
1	41223	Steer Cylinder Assembly	1
--	41594	Seal Kit	1
2	41298	Straight Fitting	2
3	46735	Cover	2
4	41794	Screw	2
5	41322	Cotter Pin	4
6	41321	Pin	2
7	41225	Bearing	4
8	43564	Washer	2
9	41210	Bearing	4
10	46736	Steer Yoke Weldment	1
11	46737	Wheel	2
12	46738	Nut	2
13	46739	Washer	2
14	41230	Bearing Cover	2
15	53269	Screw CSCS M05-0.80 x 16	8
16	43563	Cotter Pin	2
17	44648	Key	2
18	44650	Wheel Shaft	2
19	41024	Bearing	4
20	41234	Connection Plate	2
21	50429	Screw HHCS M10-1.50 x 25 Serrated Flange	12
22	41327	Washer	2
23	53347	Castle Nut M16 x 1.50	2
24	41328	Cap	2
25	53282	Screw CSCS M08-1.25 x 20	12
26	46740	Steer Yoke Weldment	1
27	41222	Bearing	2
28	41221	Tie Rod	1
29	50311	Nut NNYL M10-1.50 Flange	2
30	41199	Washer	2
31	41202	Bearing	4

# Drive Wheel Assembly, To Serial #16308570

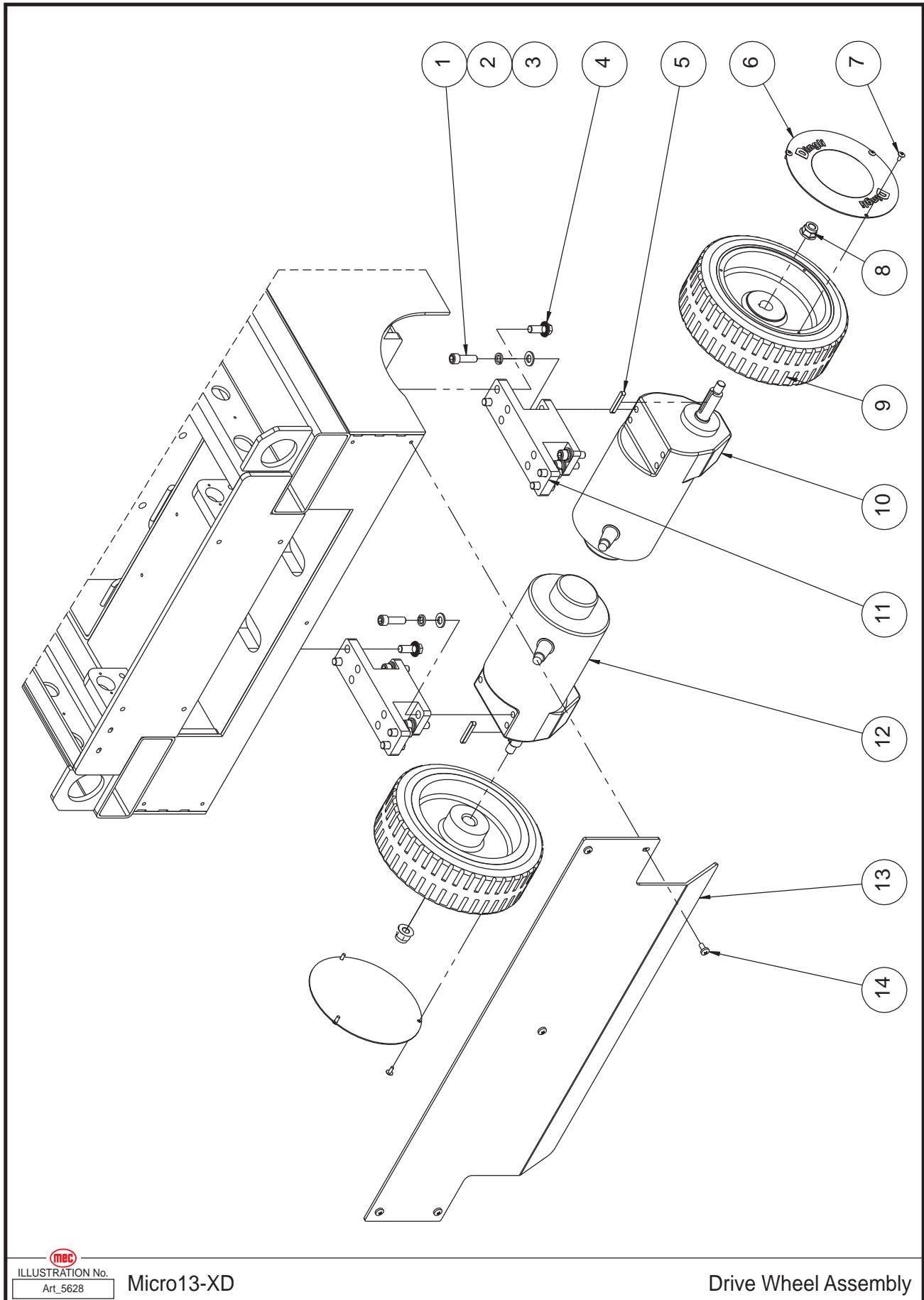

 ILLUSTRATION No. Art\_5628 Micro13-XD

Drive Wheel Assembly

Item	Part Number	Description	Qty.
1	53315	Screw SHCS 3/8-24 x 1 1/4	8
2	53054	WSHR M10 Spring Washer	8
3	50002	WSHR M10 Standard Flat Washer	8
4	50429	Screw HHCS M10-1.50 x 25 Serrated Flange	8
5	44029	Key	2
6	41323	Cover	2
7	53348	Screw THMS M04-0.70 x 10	6
8	53261	Nut NNYL M12-1.75 Flange	2
9	41228	Wheel	2
10	41240	Right Drive Motor Assembly	1
--	43751	Right Motor	1
--	42515	Reducer	1
--	44859	Output Shaft	1
--	44033	Brake	1
11	41239	Support	2
12	41240	Left Drive Motor Assembly	1
--	43752	Left Motor	1
--	42515	Reducer	1
--	44859	Output Shaft	1
--	44033	Brake	1
13	44062	Plate (With Platform Power)	1
--	42883	Connector, Drive Motor	1
14	53318	Screw PHMS M06-1.00 x 12	5

# Drive Wheel Assembly, From Serial #16308571

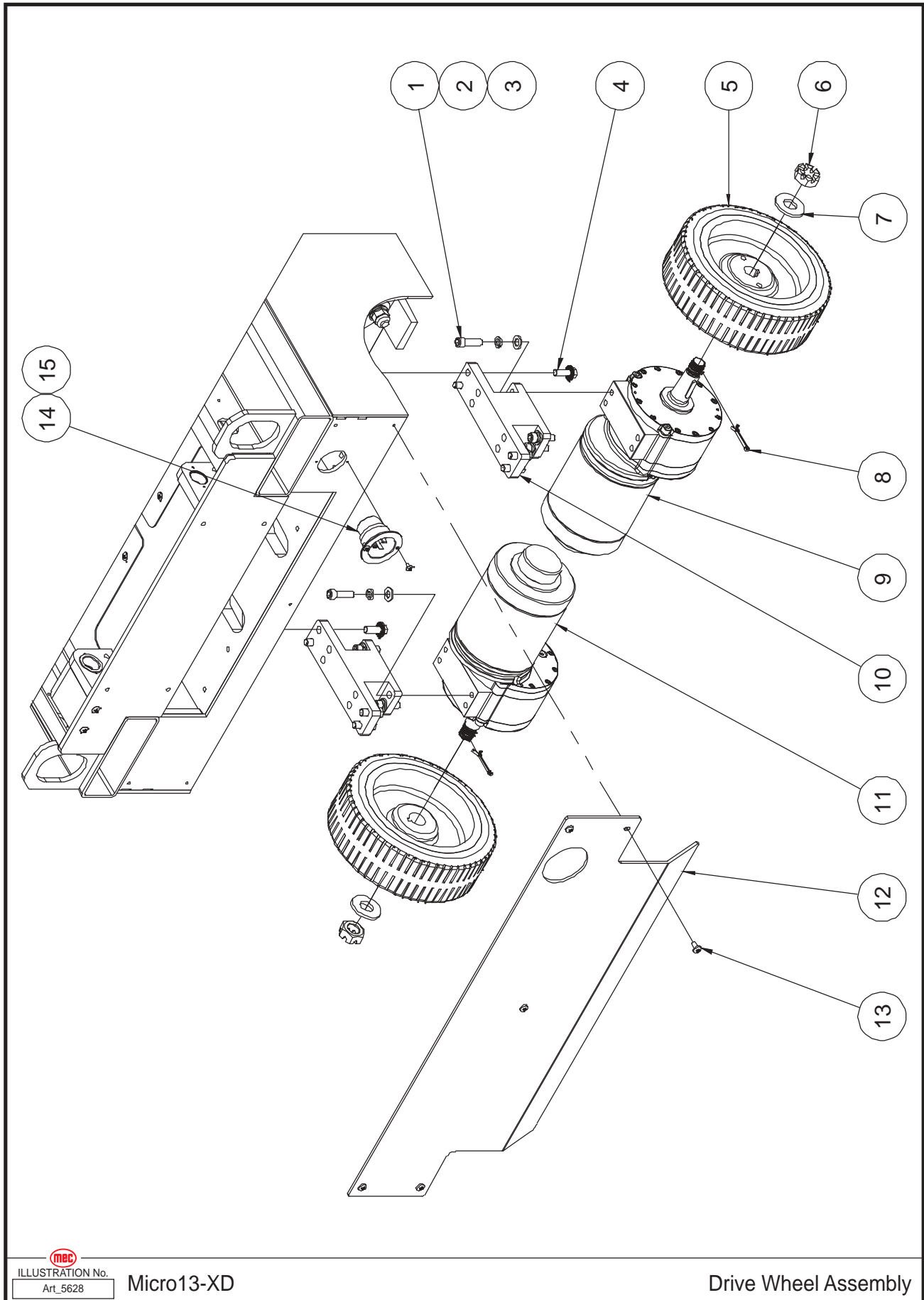

 ILLUSTRATION No. Art\_5628 Micro13-XD

Drive Wheel Assembly

Item	Part Number	Description	Qty.
1	53315	Screw SHCS 3/8-24 x 1 1/4	8
2	53054	WSHR M10 Spring Washer	8
3	50002	WSHR M10 Standard Flat Washer	8
4	50429	Screw HHCS M10-1.50 x 25 Serrated Flange	8
5	46737	Wheel	2
6	46738	Nut	2
7	46739	Washer	2
8	43563	Cotter Pin	2
9	46741	Right Drive Motor Assembly	1
--	46742	Right Motor	1
--	46743	Reducer	1
--	46744	Output Shaft	1
--	44033	Brake	1
--	46745	Key	1
10	41239	Support	2
11	46746	Left Drive Motor Assembly	1
--	46747	Left Motor	1
--	46743	Reducer	1
--	46744	Output Shaft	1
--	44033	Brake	1
--	46745	Key	1
12	46748	Plate	1
13	53318	Screw PHMS M06-1.00 x 12	5
14	41575	Plug	1
15	53263	Screw THMS M04-0.70 x 8	2

# Pothole Protection Assembly

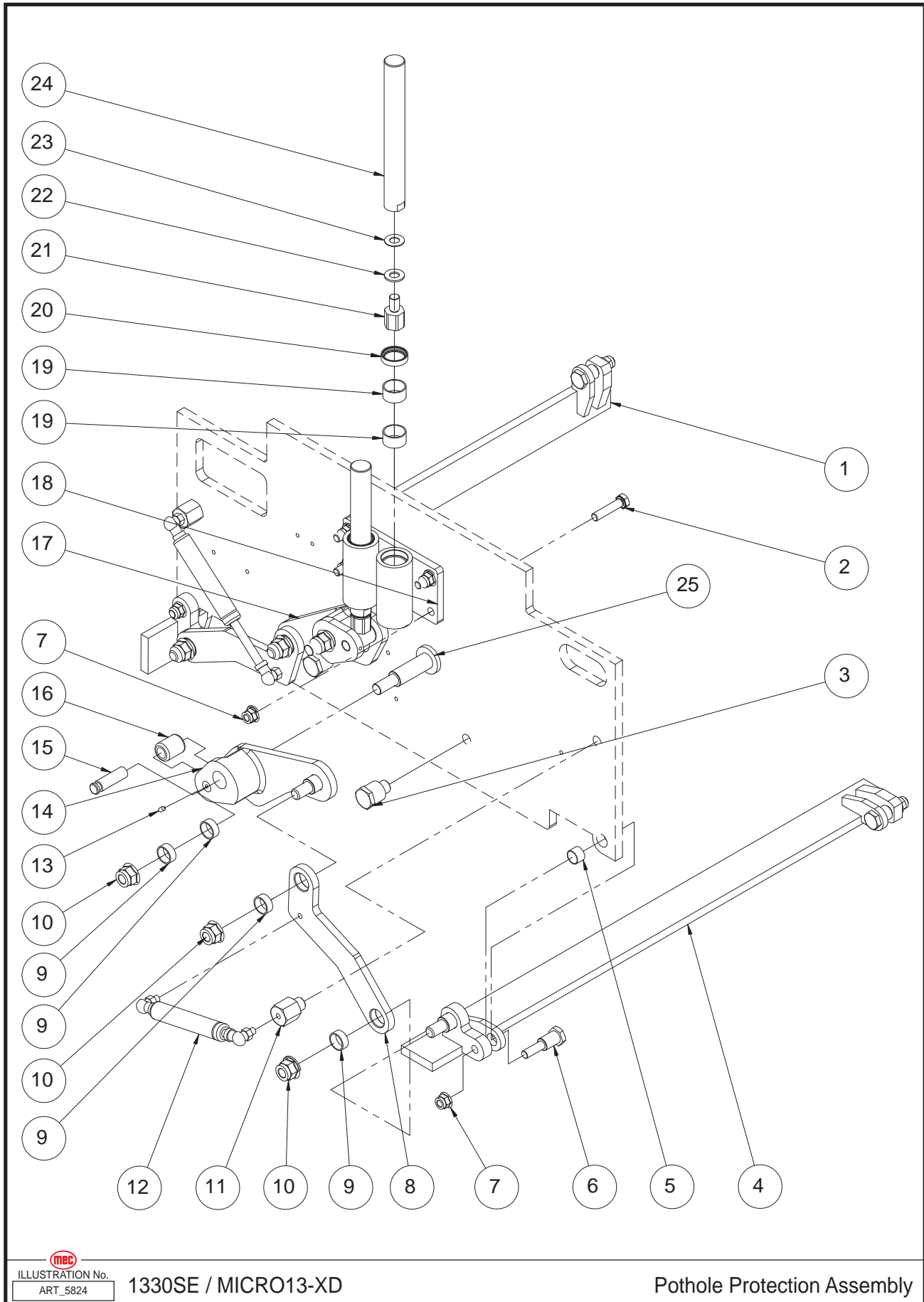

 ILLUSTRATION No. 1330SE / MICRO13-XD  
ART\_5824

Pothole Protection Assembly



Item	Part Number	Description	Qty.
1	41207	Pothole Guard Weldment (To Serial #16308570)	1
	46749	Pothole Guard Weldment (From Serial #16308571)	1
2	50430	Screw HHCS M10-1.50 x 45	4
3	41211	Pin	2
4	41208	Pothole Guard Weldment (To Serial #16308570)	1
	46750	Pothole Guard Weldment (From Serial #16308571)	1
5	41210	Bearing	4
6	41209	Pin	4
7	50311	Nut NNYL M10-1.50 Flange	8
8	41213	Pothole Link Plate	2
9	41214	Bearing	8
10	53349	Nut NNYL M14-2.00 Flange	6
11	41212	Gas Shock Strut	2
12	41215	Gas Shock	2
13	53283	Set Screw M05-0.80 x 10 Cone Point	2
14	41319	Linkage Weldment	1
15	41216	Pin	2
16	41217	Roller	2
17	41320	Linkage Weldment	1
18	44609	Pothole Guide	1
19	41203	Bearing	4
20	44610	Seal	2
21	41204	Pothole Hole Pusher Pin	2
22	44007	Adjusting Washer 2	2
23	44008	Adjusting Washer 3	2
24	41205	Pothole Hole Pusher Rod	2
25	47376	Pivot Pin, Pothole Weld	1

# Battery Pack Module, To Serial #16308570

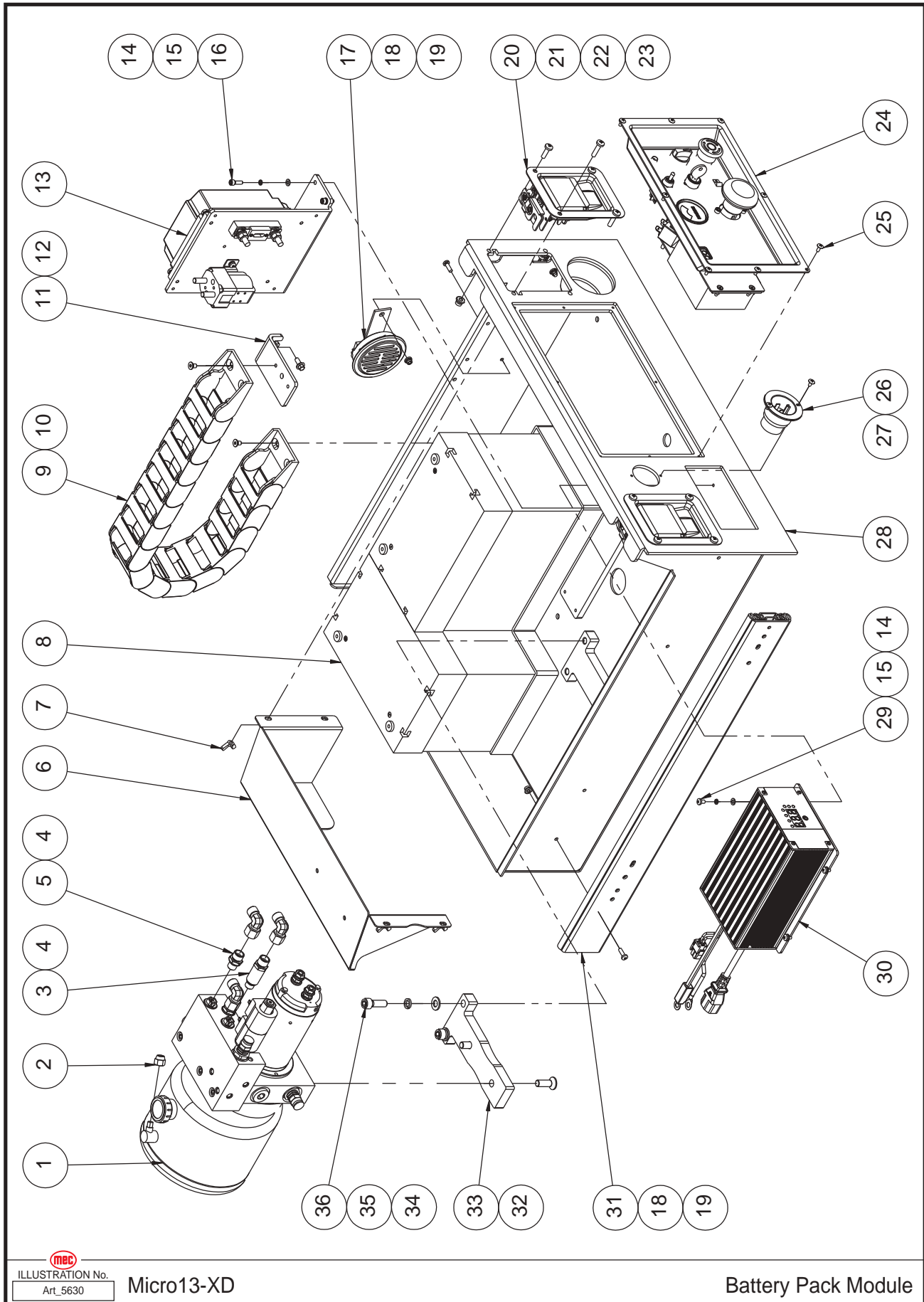

 ILLUSTRATION No. Art\_5630 Micro13-XD

Battery Pack Module

Item	Part Number	Description	Qty.
1	REF	Hydraulic Power Unit (Refer to page 50)	1
2	41413	Nut	1
3	44860	Straight Fitting	1
4	43639	Elbow	3
5	41296	Straight Fitting	2
6	44053	Protect Cover	1
7	53350	Wing Nut M06-1.00	4
8	41330	Battery	2
9	44039	Towline	1
10	53352	Screw CSCS M06-1.00 x 10	4
11	44040	Towline Bracket	1
12	53273	Screw HHCS M06-1.00 x 14 Serrated Flange	2
13	REF	Motor Controller Assembly (Refer to page 52)	1
14	53038	WSHR M05 Standard Flat Washer	8
15	53043	WSHR M05 Spring Washer	8
16	50359	Screw SHCS M05-0.80 x 16	4
17	41075	Horn	1
18	53351	Screw PHMS M05-0.80 x 16	8
19	53281	Nut NNYL M05-0.80 Flange	8
20	43977	Latch	2
21	53264	Screw PHMS M06-1.00 x 20	4
22	53353	Screw PHMS M06-1.00 x 25	4
23	50568	Nut NNYL M06-1.00 Flange	8
24	REF	Ground Control Assembly (Refer to page 54)	1
25	53348	Screw THMS M04-0.70 x 10	8
26	41575	Plug	1
27	53263	Screw THMS M04-0.70 x 8	2
28	44051	Battery Tray Weldment	1
29	53222	Screw PHMS M05-0.80 x 8	4
30	42904	Charger	1
31	41255	Glide Track	2
32	53225	Screw CSCS M10-1.50 x 30	2
33	41337	Bracket	1
34	50002	WSHR M10 Standard Flat Washer	2
35	53054	WSHR M10 Spring Washer	2
36	50127	Screw SHCS M10-1.50 x 30	2

REF - Reference

# Battery Pack Module, From Serial #16308571

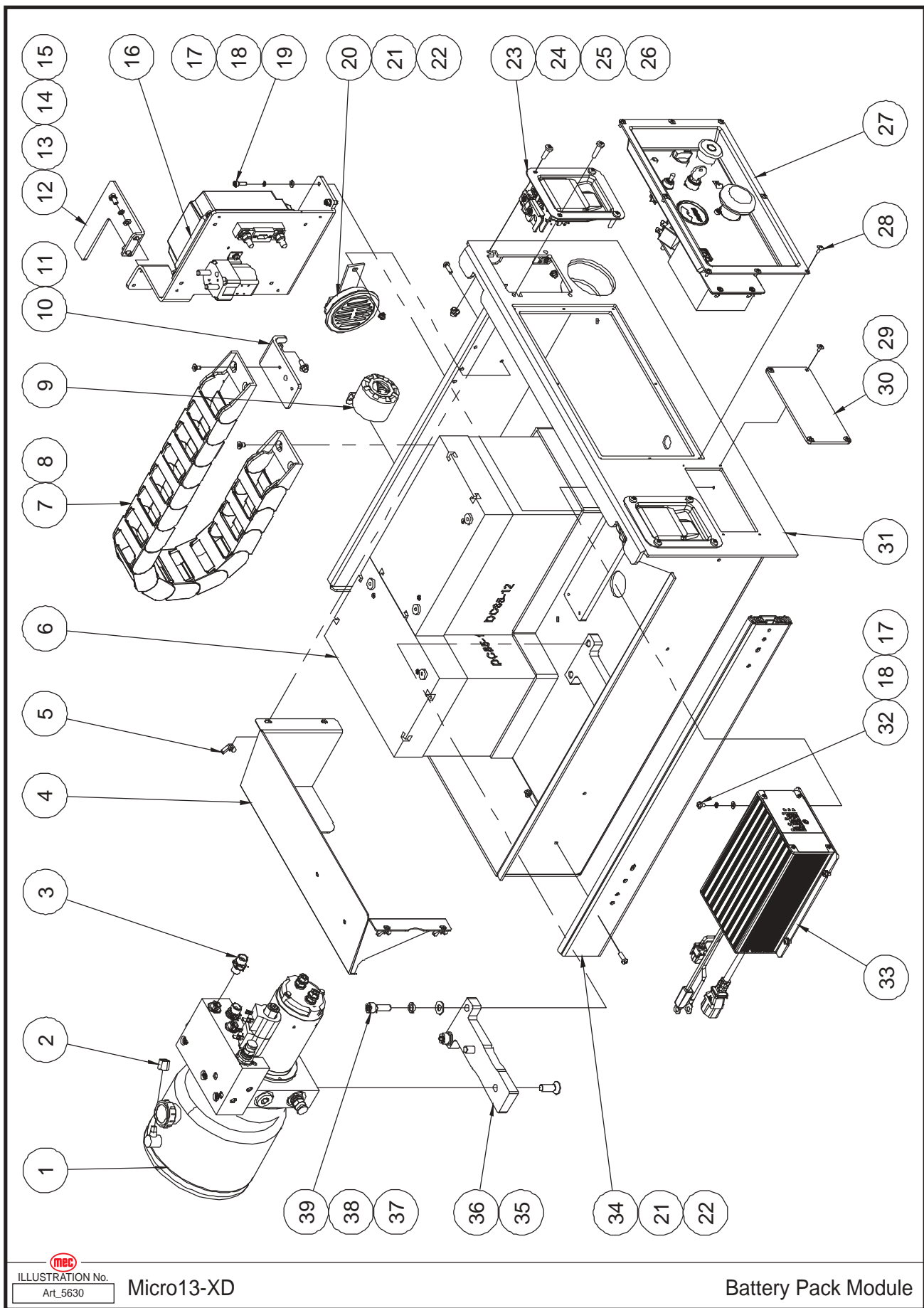

ILLUSTRATION No. **Micro13-XD**  
Art. 5630

Battery Pack Module



Item	Part Number	Description	Qty.
1	42891	Hydraulic Power Unit (Refer to page 50)	1
2	41413	Nut	1
3	41296	Straight Fitting	3
4	44053	Protect Cover	1
5	53350	Wing Nut M06-1.00	4
6	41330	Battery	2
7	44039	Towline	1
8	53352	Screw CSCS M06-1.00 x 10	4
9	41074	Alarm	1
10	44040	Towline Bracket	1
11	53273	Screw HHCS M06-1.00 x 14 Serrated Flange	2
12	46751	Press Plate	1
13	53104	Screw HHCS M06-1.00 x 12	2
14	53046	WSHR M06 Spring Washer	2
15	50000	WSHR M06 Standard Flat Washer	2
16	46752	Motor Controller Assembly (Refer to page 52)	1
17	53038	WSHR M05 Standard Flat Washer	8
18	53043	WSHR M05 Spring Washer	8
19	50359	Screw SHCS M05-0.80 x 16	4
20	41075	Horn	1
21	53351	Screw PHMS M05-0.80 x 16	8
22	53281	Nut NNYL M05-0.80 Flange	8
23	43977	Latch	2
24	53264	Screw PHMS M06-1.00 x 20	4
25	53353	Screw PHMS M06-1.00 x 25	4
26	50568	Nut NNYL M06-1.00 Flange	8
27	44052	Ground Control Assembly (Refer to page 54)	1
28	53348	Screw THMS M04-0.70 x 10	8
29	53263	Screw THMS M04-0.70 x 8	4
30	44612	Cover	1
31	44051	Battery Tray Weldment	1
32	53222	Screw PHMS M05-0.80 x 8	4
33	42904	Charger	1
34	41255	Glide Track	2
35	53225	Screw CSCS M10-1.50 x 30	2
36	41337	Bracket	1
37	50002	WSHR M10 Standard Flat Washer	2
38	53054	WSHR M10 Spring Washer	2
39	50127	Screw SHCS M10-1.50 x 30	2

REF - Reference

# Hydraulic Power Unit

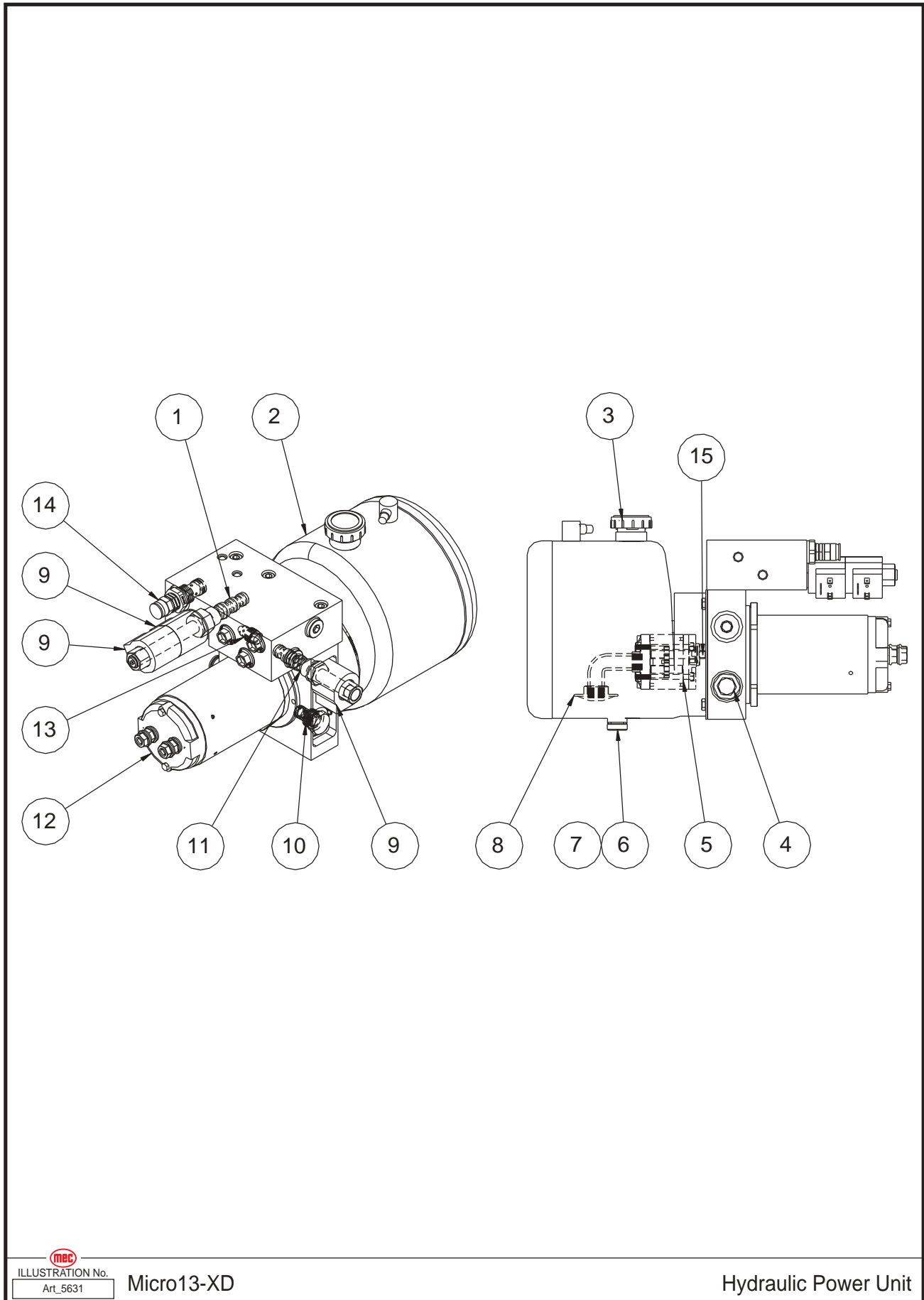

 ILLUSTRATION No. **Micro13-XD**  
Art\_5631

Hydraulic Power Unit

Item	Part Number	Description	Qty.
1	41246	Solenoid Valve Spool	1
2	41247	Tank	1
3	42901	Tank Cover	1
4	43807	Relief Valve	1
5	42524	Pump	1
6	43808	Plug	1
7	43777	Washer	1
8	43809	Filter Web	1
9	41894	Coil (To Serial #16308570)	3
	43810	Coil (From Serial #16308571)	3
10	43811	Check Valve	1
11	41245	Solenoid Valve Spool	1
12	41243	Motor	1
13	43812	Pressure Compensation Valve	1
14	43813	Relief Valve	1
15	42894	Coupler, Motor Pump	1

# Motor Controller Assembly

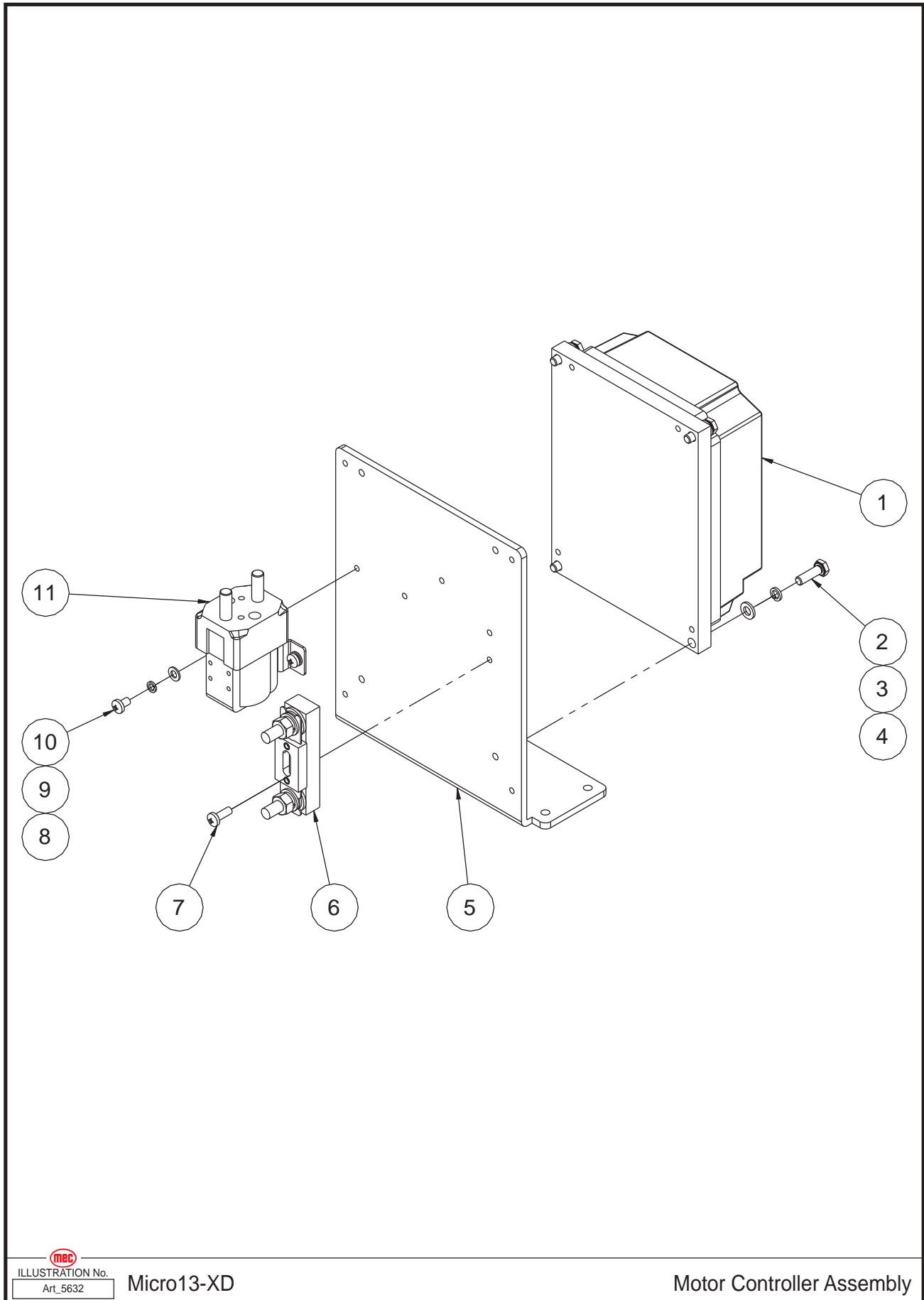

 ILLUSTRATION No. **Micro13-XD**  
Art\_5632

Motor Controller Assembly



Item	Part Number	Description	Qty.
1	41610	Motor Controller	1
2	50028	Screw HHCS M06-1.00 x 20	4
3	53046	WSHR M06 Spring Washer	4
4	50000	WSHR M06 Standard Flat Washer	4
5	41333	Mounting Plate (To Serial #16308570)	1
	46753	Mounting Plate (From Serial #16308571)	1
6	41251	150A Fuse Assembly	1
--	44031	150A Fuse	1
--	41092	Fuse Seat	1
7	53355	Screw PHMS M05-0.80 x 14	2
8	53038	WSHR M05 Standard Flat Washer	2
9	53043	WSHR M05 Spring Washer	2
10	53222	Screw PHMS M05-0.80 x 8	2
11	41331	DC Contactor	1

# Ground Control Assembly

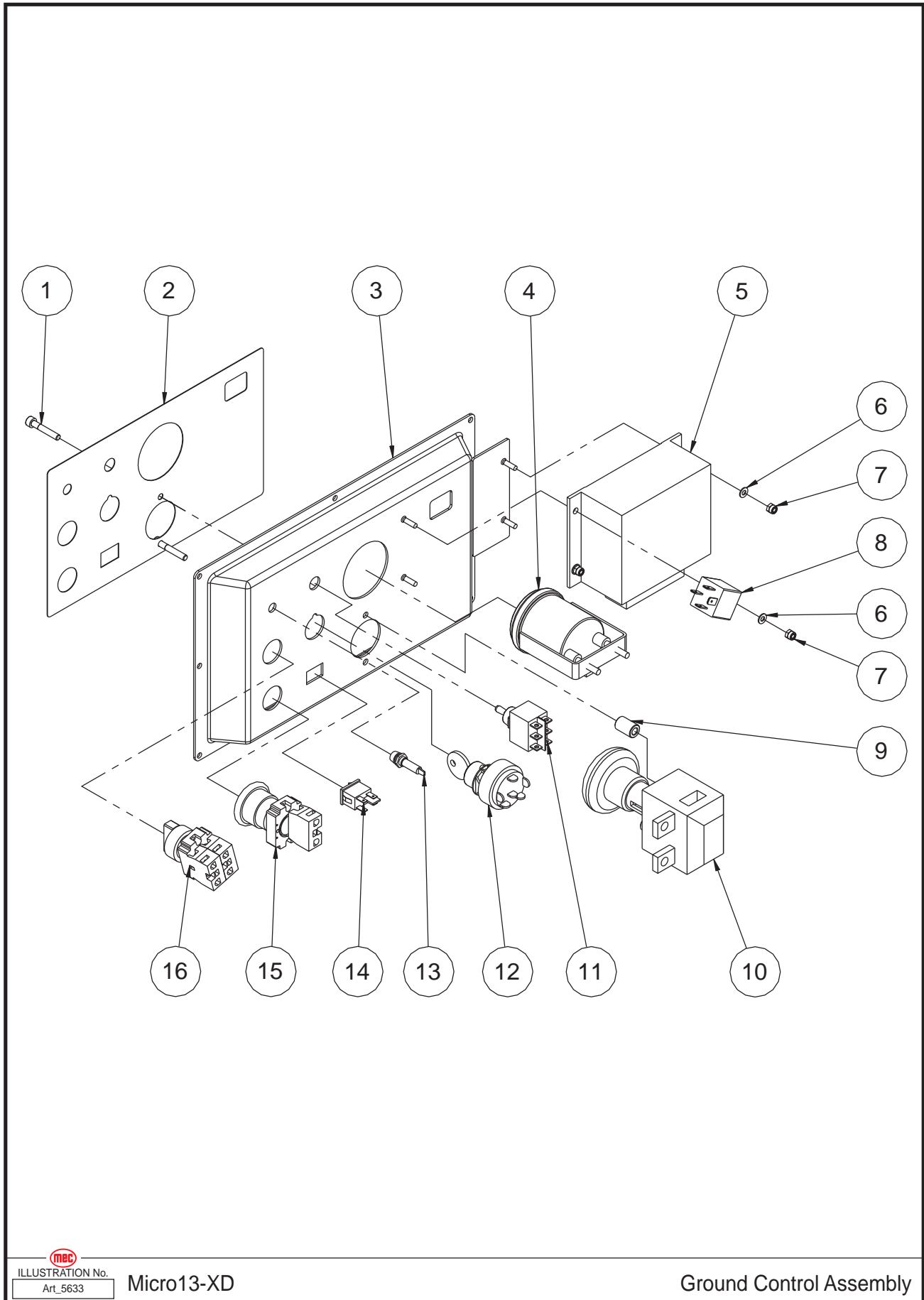

 ILLUSTRATION No. **Micro13-XD**  
Art\_5633

Ground Control Assembly

Item	Part Number	Description	Qty.
1	53171	Screw SHCS M05-0.80 x 30	2
2	43904	Decal, Ground Control Panel (1330SE)	1
3	44052	Ground Control Panel Weldment	1
4	41070	Hour Meter (To Serial #16308570)	1
	46754	Hour Meter (From Serial #16308571)	1
5	43989	Controller	1
6	50284	WSHR M04 Standard Flat Washer	4
7	50285	Nut NNYL M04 x 0.70	4
8	41334	Relay	1
9	44054	Sleeve Pipe	2
10	42071	Power Switch	1
11	41419	Toggle Switch	1
12	41418	Key Switch	1
--	91574	Key	1
13	41421	Indicator	1
14	43991	Brake Release Switch	1
15	41422	Emergency Stop Switch	1
--	43098	Red Mushroom Head	1
--	43097	Base With 1 NC Contact	1
16	43992	Select Switch (To Serial #16308570)	1
	46755	Select Switch (From Serial #16308571)	1
--	43993	Select Switch Head	1
--	43994	Base With 1 NO Contact	1
--	43096	NC Contact	1

# Chassis and Accessories, To Serial #16308570

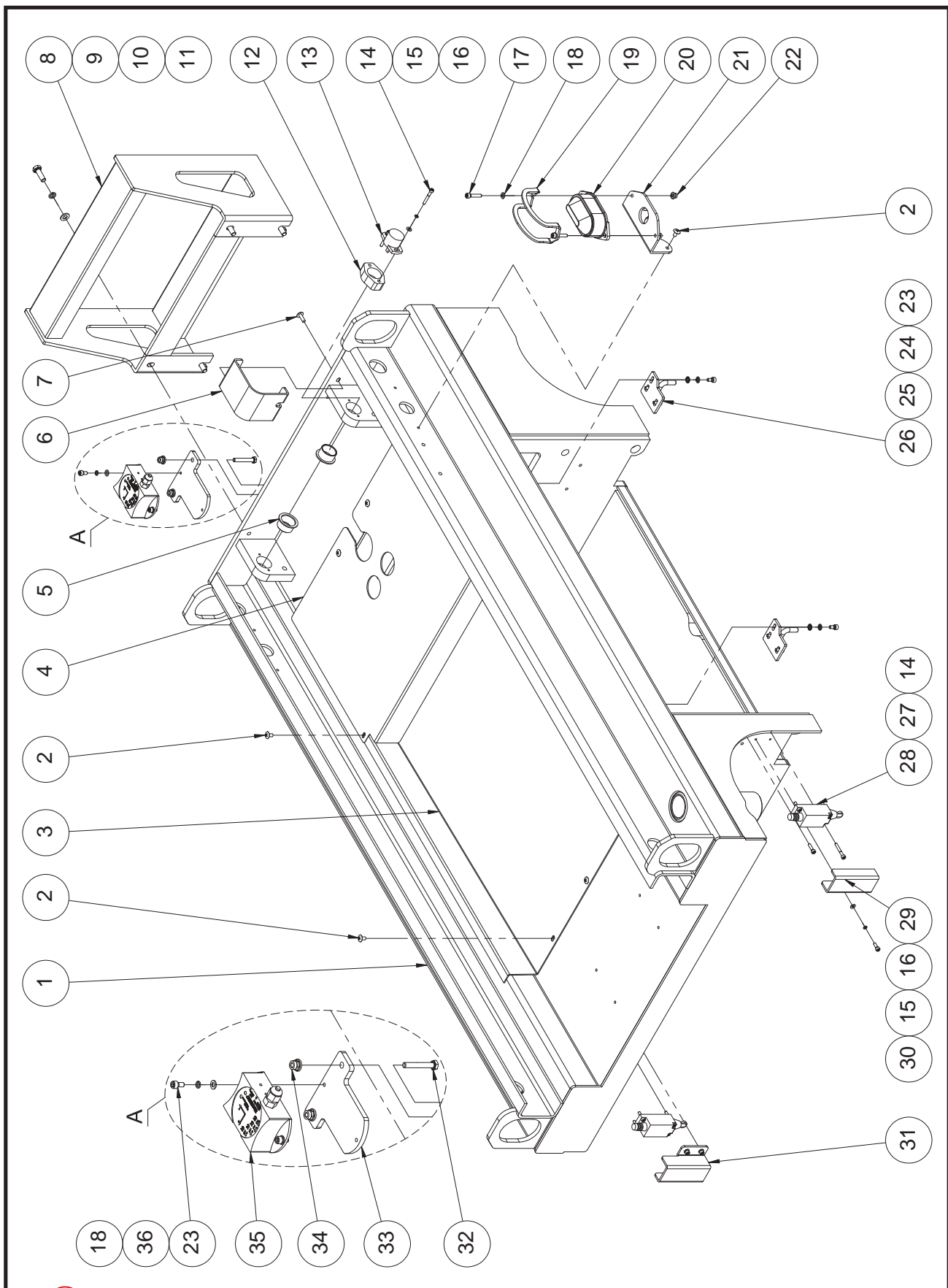

 ILLUSTRATION No. 1330SE / MICRO13-XD  
ART\_5825

Chassis and Accessories

Item	Part Number	Description	Qty.
1	44041	Frame Weldment	1
2	53265	Screw THMS M05-0.80 x 10	9
3	41308	Cover	1
4	41311	Cover	1
5	41257	Bearing	2
6	41312	Sensor Cover	1
7	53223	Screw THMS M05-0.80 x 16	2
8	41193	Ladder	1
9	50031	Screw HHCS M08-1.25 x 25	4
10	53055	WSHR M08 Spring Washer	4
11	50001	WSHR M08 Standard Flat Washer	4
12	41194	Sensor Bracket	1
13	41195	Rotary Sensor	1
14	50284	WSHR M04 Standard Flat Washer	6
15	53062	WSHR M04 Spring Washer	6
16	53065	Screw SHCS M04-0.70 x 30	6
17	53356	Screw SHCS M05-0.80 x 25	2
18	53038	WSHR M05 Standard Flat Washer	4
19	41309	Beacon Cover	1
20	41310	Beacon	1
21	42406	Beacon Bracket	1
22	53281	Nut NNYL M05-0.80 Flange	2
23	53173	Screw SHCS M05-0.80 x 10	8
24	53425	WSHR M05 Serrated Lock Washer Internal Teeth	6
25	53426	WSHR M05 Serrated Lock Washer External Teeth	6
26	43978	Lock Clasp	2
27	53113	Screw SHCS M04-0.70 x 16	4
28	41197	Limit Switch	2
29	41315	Switch Cover	1
30	50423	Screw SHCS M04-0.70 x 12	4
31	41198	Switch Cover	1
32	50289	Screw HHCS M06-1.00 x 40	2
33	42403	Sensor Bracket	1
34	50568	Nut NNYL M06-1.00 Flange	2
35	41098	Tilt Sensor	1
36	53043	WSHR M05 Spring Washer	2

# Chassis and Accessories, From Serial #16308571

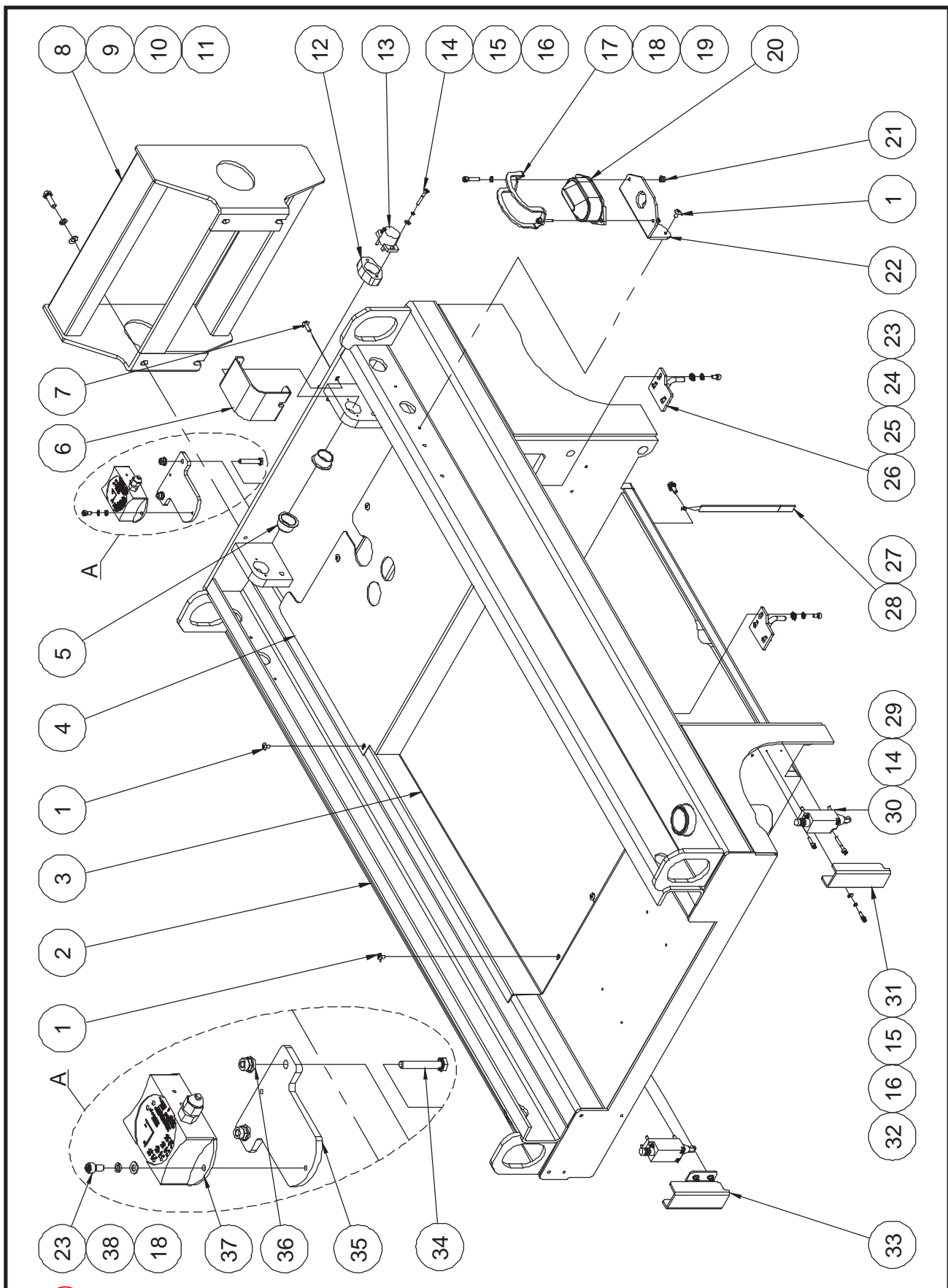
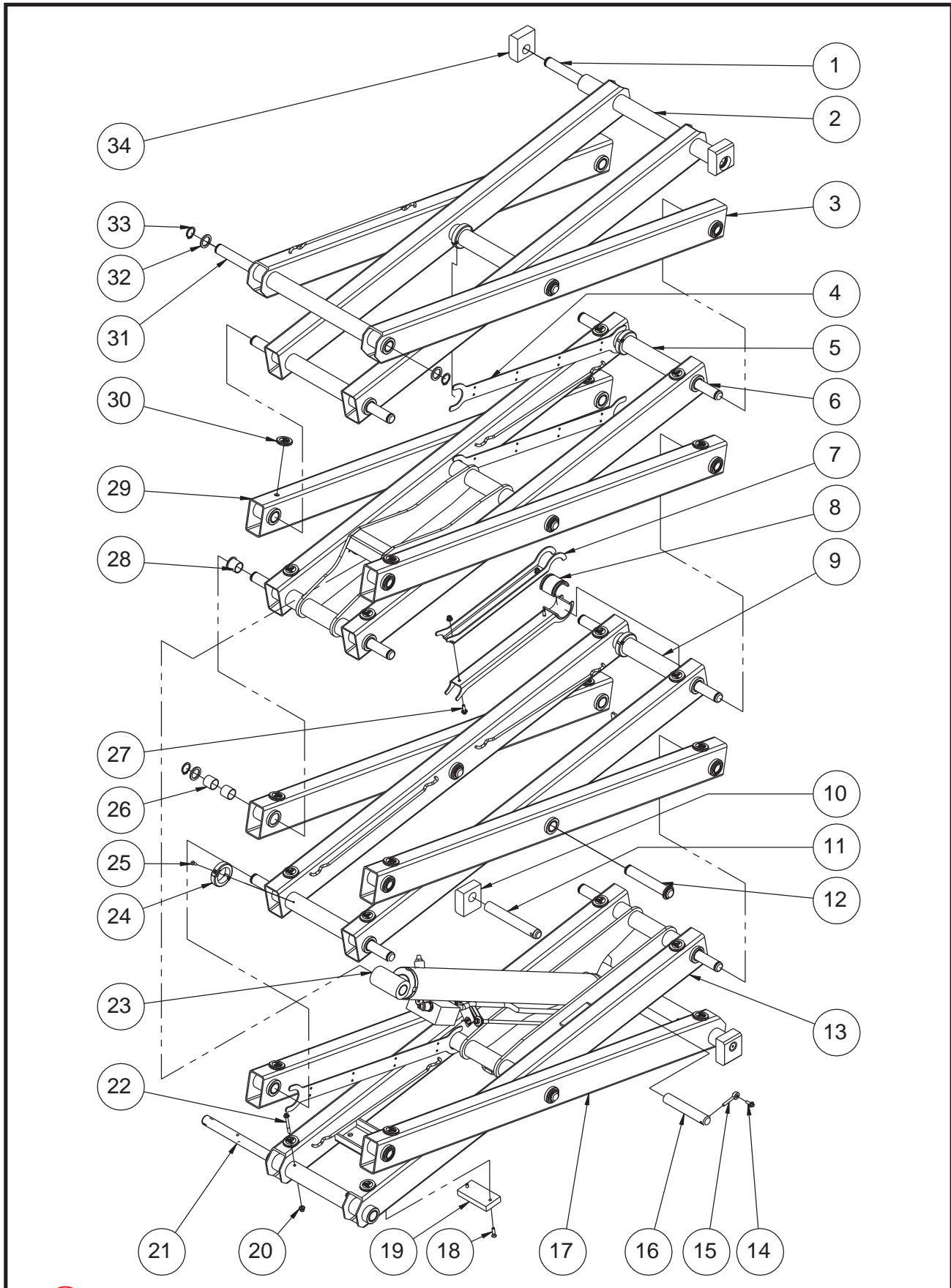

 ILLUSTRATION No. **1330SE / MICRO13-XD** Chassis and Accessories  
ART\_5825

Item	Part Number	Description	Qty.
1	53265	Screw THMS M05-0.80 × 10	9
2	44041	Frame Weldment	1
3	41308	Cover	1
4	41311	Cover	1
5	41257	Bearing	2
6	41312	Sensor Cover	1
7	53223	Screw THMS M05-0.80 × 16	2
8	44615	Ladder	1
9	50031	Screw HHCS M08-1.25 × 25	4
10	53055	WSHR M08 Spring Washer	4
11	50001	WSHR M08 Standard Flat Washer	4
12	41194	Sensor Bracket	1
13	41195	Rotary Sensor	1
14	53065	Screw SHCS M04-0.70 × 30	6
15	53062	WSHR M04 Spring Washer	6
16	50284	WSHR M04 Standard Flat Washer	6
17	41309	Beacon Cover	1
18	53038	WSHR M05 Standard Flat Washer	4
19	53356	Screw SHCS M05-0.80 × 25	2
20	46264	Beacon	1
21	53281	Nut NNYL M05-0.80 Flange	2
22	42406	Beacon Bracket	1
23	53173	Screw SHCS M05-0.80 × 10	8
24	53425	WSHR M05 Serrated Lock Washer Internal Teeth	6
25	53426	WSHR M05 Serrated Lock Washer External Teeth	6
26	43978	Lock Clasp	2
27	53273	Screw HHCS M06-1.00 × 14 Serrated Flange	1
28	41003	Ground Strap	1
29	53113	Screw SHCS M04-0.70 × 16	4
30	41197	Limit Switch	2
31	41315	Switch Cover	1
32	50423	Screw SHCS M04-0.70 × 12	4
33	41198	Switch Cover	1
34	50289	Screw HHCS M06-1.00 × 40	2
35	42403	Sensor Bracket	1
36	50568	Nut NNYL M06-1.00 Flange	2
37	41098	Tilt Sensor	1
38	53043	WSHR M05 Spring Washer	2

# Scissor Assembly





Item	Part Number	Description	Qty.
1	41576	Pin	1
2	44047	Inner Arm 4 (To Serial #16308570)	1
	46756	Inner Arm 4 (From Serial #16308571)	1
3	44049	Outer Arm 3 (To Serial #16308570)	1
	46757	Outer Arm 3 (From Serial #16308571)	1
4	41352	Cable Bridge	3
5	44046	Inner Arm 3 (To Serial #16308570)	1
	46758	Inner Arm 3 (From Serial #16308571)	1
6	41577	Pin	9
7	41263	Safety Arm	2
8	41262	Safety Arm Bushing	2
9	44045	Inner Arm 2 (To Serial #16308570)	1
	46759	Inner Arm 2 (From Serial #16308571)	1
10	41256	Chassis Slider	2
11	41338	Pin	2
12	41349	Pin	2
13	44044	Inner Arm 1 (To Serial #16308570)	1
	46760	Inner Arm 1 (From Serial #16308571)	1
14	53256	Screw HHCS M06-1.00 x 16 Serrated Flange	2
15	42449	Pin	2
16	41345	Pin	2
17	44048	Outer Arm 1 (To Serial #16308570)	1
	46761	Outer Arm 1 (From Serial #16308571)	1
18	50386	Screw CSCS M06-1.00 x 25	2
19	41350	Pothole Pusher	1
20	50568	Nut NNYL M06-1.00 Flange	6
21	41258	Pin	1
22	53357	Screw HHCS M06-1.00 x 55 Flange	4
23	REF	Lift Cylinder Assembly (Refer to page 72)	1
24	44050	Collar	4
25	53269	Screw CSCS M05-0.80 x 16	4
26	41287	Bearing	44
27	53255	Screw HHCS M06-1.00 x 20 Serrated Flange	2
28	42446	Bearing	26
29	41343	Outer Arm 2 (To Serial #16308570)	4
	46762	Outer Arm 2 (From Serial #16308571)	4
30	41114	Block	32
31	42457	Pin	1
32	41354	Washer	26
33	42437	Circlips	26
34	41256	Platform Slider	2

# Main Platform Assembly

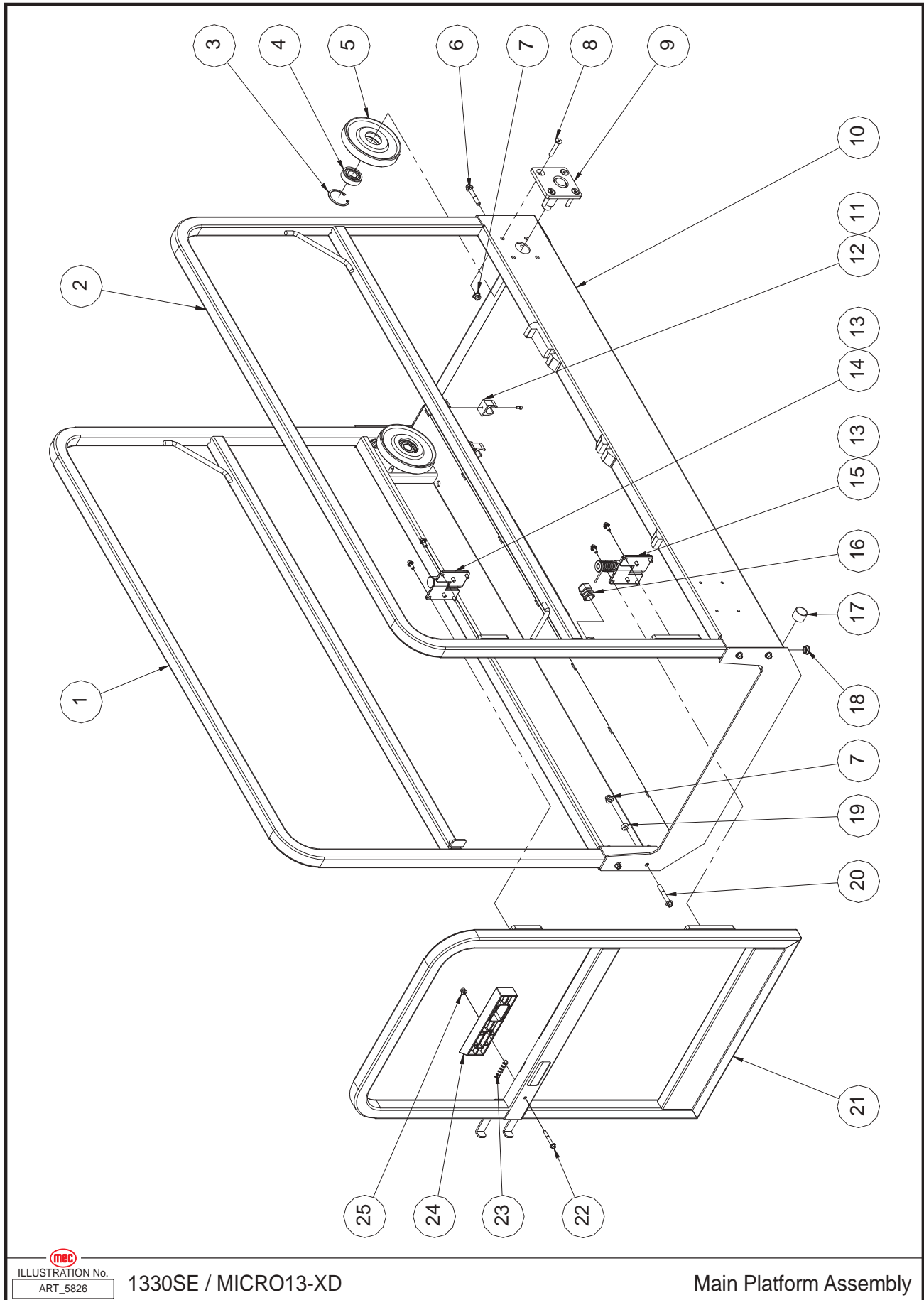

  
ILLUSTRATION No.  
ART\_5826

1330SE / MICRO13-XD

Main Platform Assembly

Item	Part Number	Description	Qty.
1	44582	Left Main Rail	1
2	44583	Right Main Rail	1
3	43618	Circlips	2
4	41131	Bearing	2
5	41269	Roller	2
6	53358	Screw HHCS M08-1.25 x 50 Flange	4
7	50313	Nut NNYL M08-1.25 Flange	8
8	53275	Screw CSCS M08-1.25 x 45	8
9	41360	Roller Bracket	2
10	41272	Main Deck Weldment	1
11	53276	Screw PHMS M04-0.70 x 8	2
12	41134	Clip	2
13	53273	Screw HHCS M06-1.00 x 14 Serrated Flange	12
14	41127	Hinge A	1
15	41128	Hinge B	1
16	41273	Water-Proof Joint	1
17	41046	Bearing	2
18	41275	Sheath	1
19	42462	Washer	4
20	53359	Screw HHCS M08-1.25 x 55 Flange	4
21	44584	Entry Gate	1
22	53360	Screw HHCS M06-1.00 x 45 Flange	1
23	41277	Spring	1
24	41278	Latch Handle	1
25	50568	Nut NNYL M06-1.00 Flange	1

# Platform Extension Assembly

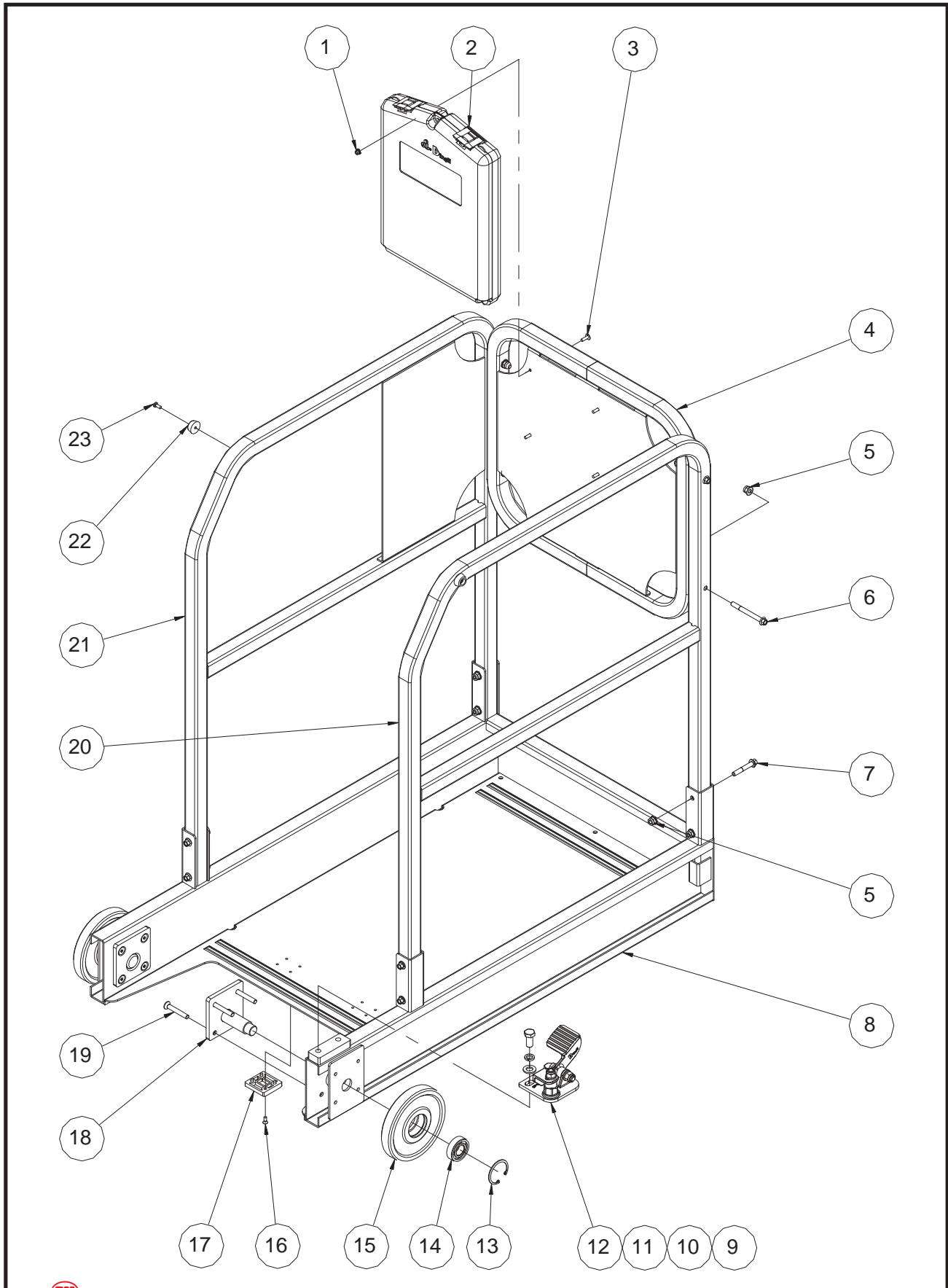

 ILLUSTRATION No. **1330SE / MICRO13-XD** Platform Extension Assembly  
ART\_5827

Item	Part Number	Description	Qty.
1	53281	Nut NNYL M05-0.80 Flange	4
2	43319	Manual Box	1
3	53223	Screw THMS M05-0.80 × 16	4
4	41283	Front Rail	1
5	50313	Nut NNYL M08-1.25 Flange	12
6	53409	Screw HHCS M08-1.25 × 80 Flange	4
7	53358	Screw HHCS M08-1.25 × 50 Flange	8
8	44586	Extension Deck Weldment	1
9	50038	Screw HHCS M12-1.50 × 25	2
10	53148	WSHR M12 Spring Washer	2
11	50003	WSHR M12 Standard Flat Washer	2
12	44599	Platform Locking Device Assembly (Refer to page 70)	1
13	43618	Circlips	2
14	41131	Bearing	2
15	41141	Roller 2	2
16	53279	Screw CSCS M05-0.80 × 12	8
17	41284	Slide Pad	2
18	41360	Roller Bracket	2
19	53280	Screw CSCS M08-1.25 × 55	8
20	44812	Right Extension Rail	1
21	44800	Left Extension Rail	1
22	41120	Bumper	2
23	53378	Screw PHMS M05-0.80 × 12	2

REF - Reference

# Platform Control Assembly

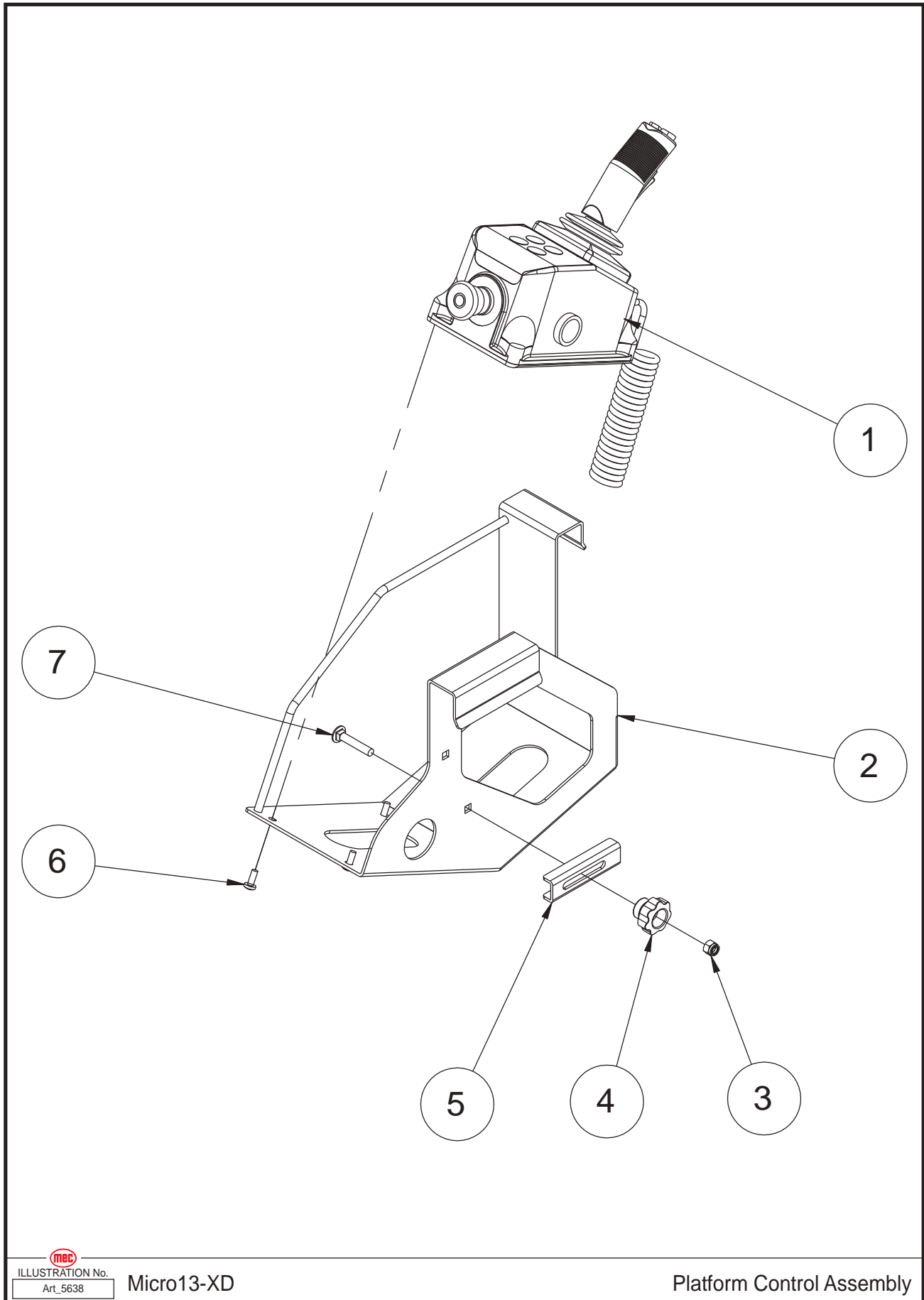

  
ILLUSTRATION No. **Micro13-XD**  
Art\_5638

Platform Control Assembly

Item	Part Number	Description	Qty.
1	41137	Platform Control Box Assembly (To Serial #16308570) (Refer to page 68)	1
	44280	Platform Control Box Assembly (From Serial #16308571) (Refer to page 68)	1
2	42499	Platform Control Box Mount Bracket	1
3	50048	NNYL M08 x 1.25	1
4	42501	Handle	1
5	42500	Locating Plate	1
6	53231	PHMS M06-1.00 x 16	4
7	53248	CARB M08-1.25 x 45	1

REF - Reference

# Platform Control Box Assembly

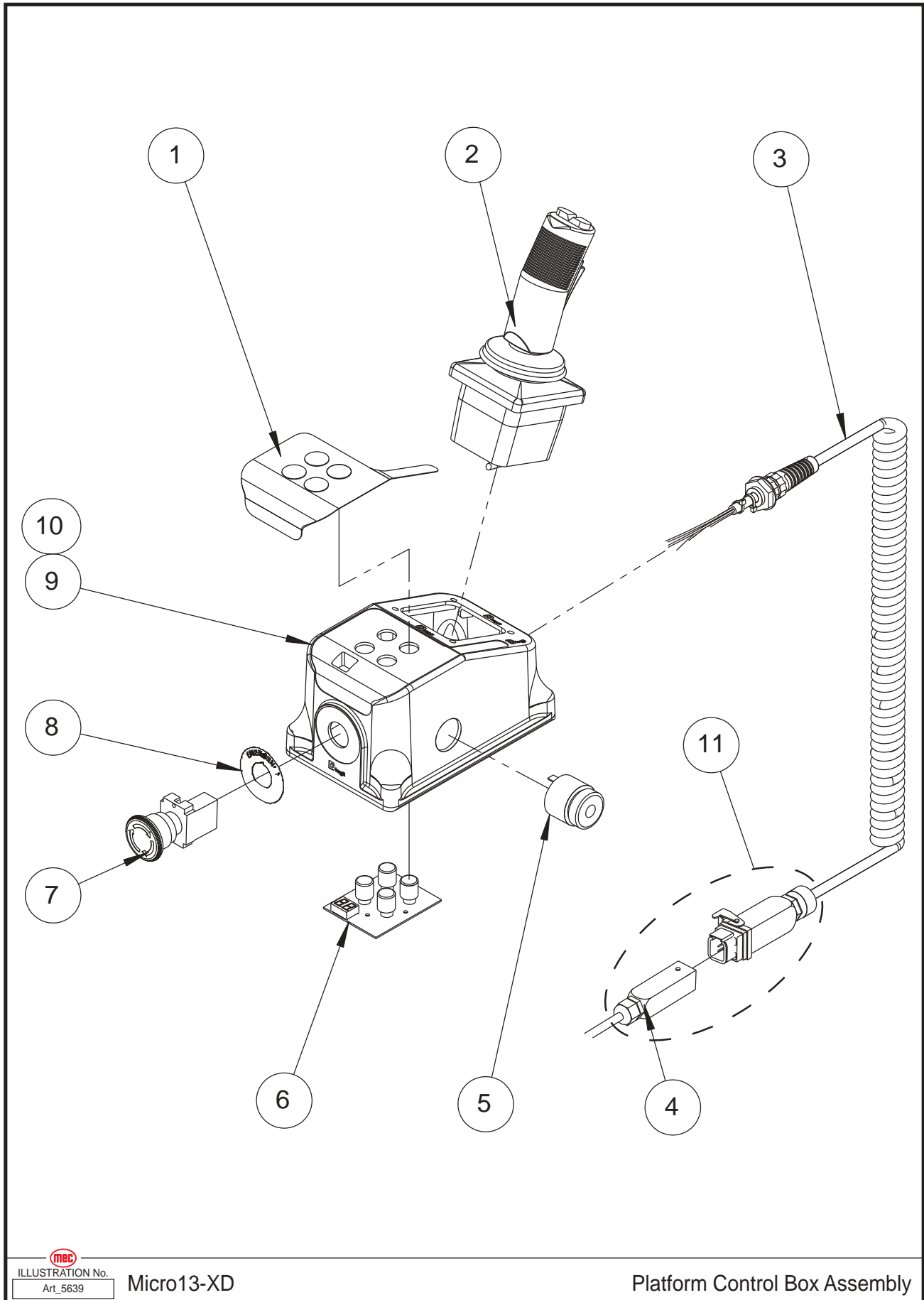

 ILLUSTRATION No. **Micro13-XD**  
Art\_5639

Platform Control Box Assembly



Item	Part Number	Description	Qty.
1	41632	Decal, Platform Control Panel	1
2	41149	Joystick	1
--	43621	Function Enable Switch	1
--	41150	Joystick Cover	1
--	43622	Joystick Steer Switch	1
--	43623	Switch Boot	1
3	41152	Coil Cord	1
--	43624	Housing	1
--	43625	Male Insert	1
--	43626	Male Contacts	5
--	43627	Cable Gland	1
4	43999	Platform Control Box Harness (To Serial #16308570)	1
	46763	Platform Control Box Harness (From Serial #16308571)	1
--	43628	Hood	1
--	43629	Female Insert	1
--	43630	Female Contacts	5
--	43627	Cable Gland	1
5	41568	Alarm	1
--	43631	Alarm Nut	1
6	41156	Main Board	1
--	41155	Button	4
7	41157	Emergency Stop Switch	1
--	43632	Red Mushroom Head	1
--	43633	Base With 1 NC Contact	1
8	42915	Decal, Emergency Stop Panel	1
9	43634	Enclosure	1
10	43635	Cover Bottom	1
11	41271	Replacement Connector, Gray	1

# Platform Locking Device Assembly

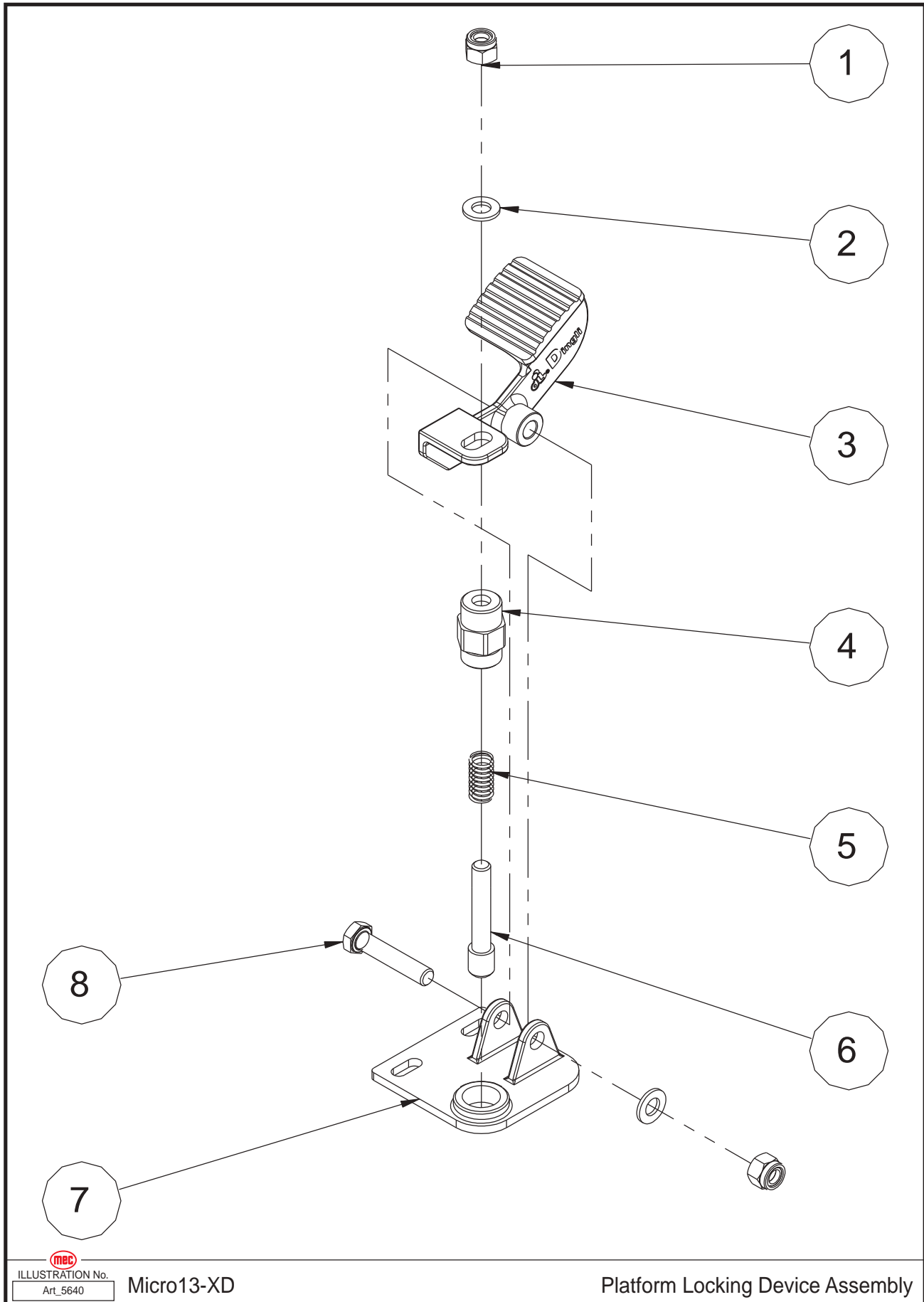

 ILLUSTRATION No. **Micro13-XD**  
Art\_5640

Platform Locking Device Assembly

<b>Item</b>	<b>Part Number</b>	<b>Description</b>	<b>Qty.</b>
1	50049	Nut NNYL M10 × 1.50	2
2	50002	WSHR M10 Standard Flat Washer	2
3	41143	Foot Pedal	1
4	41144	Lock Pin Housing	1
5	41145	Spring	1
6	41146	Lock Pin	1
7	44767	Bracket	1
8	50020	Screw HHCS M10-1.50 × 50	1

# Lift Cylinder Assembly

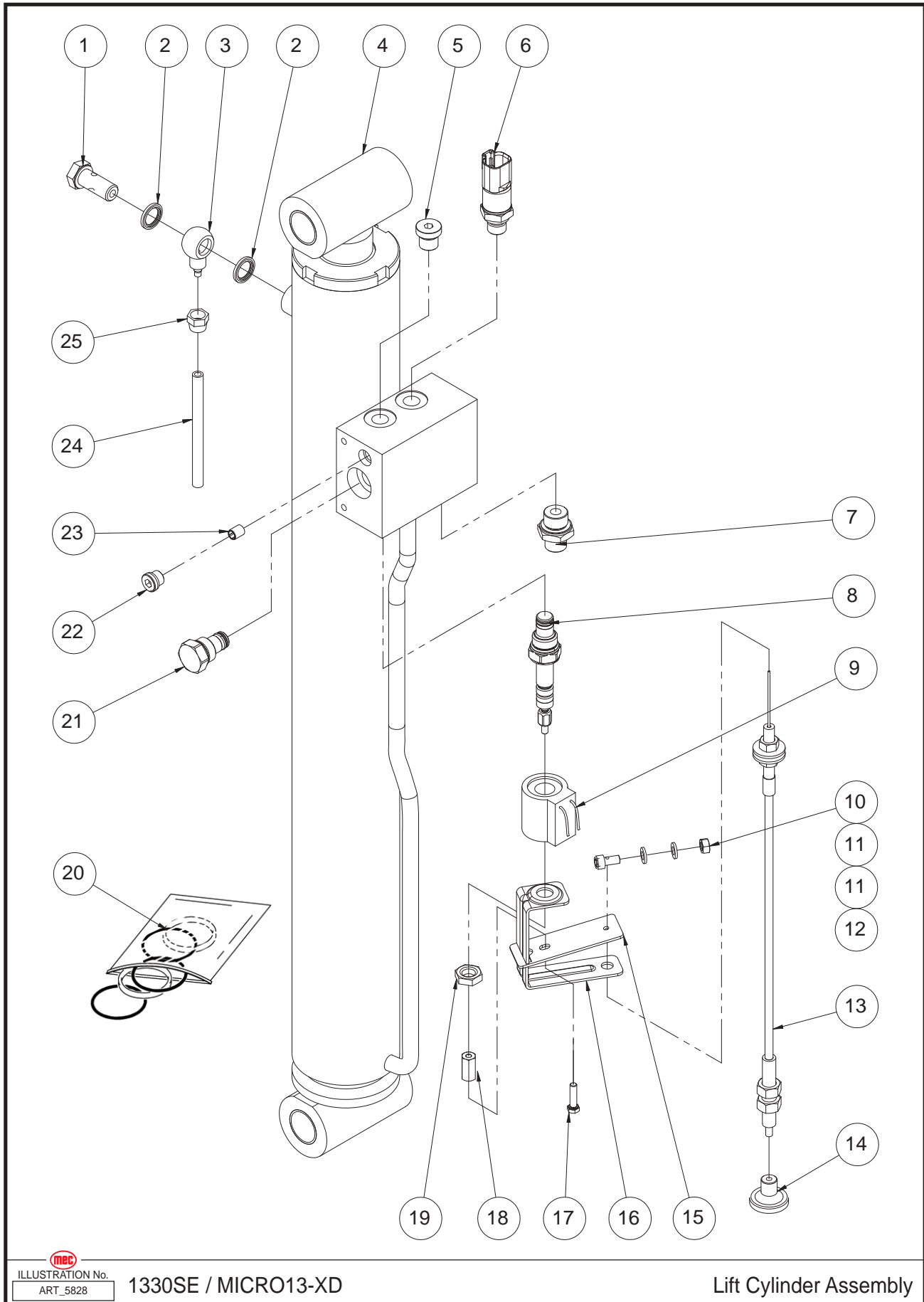

  
ILLUSTRATION No.  
ART\_5828

1330SE / MICRO13-XD

Lift Cylinder Assembly

Item	Part Number	Description	Qty.
1	41166	Fitting	1
2	43361	Washer	2
3	41167	Fitting	1
4	41290	Lift Cylinder	1
5	42480	Plug	1
6	44448	Pressure Sensor	1
7	43638	Straight Fitting	1
8	44003	Solenoid Valve Spool	1
9	41929	Coil (To Serial #16308570)	1
	46764	Coil (From Serial #16308571)	1
10	53361	Nut NHEX M06-1.00	1
11	50000	WSHR M06 Standard Flat Washer	2
12	42466	Screw	1
13	41252	Emergency Down Cable Assembly (To Serial #16308570)	1
	46765	Emergency Down Cable Assembly (From Serial #16308571)	1
14	41162	Lowering Knob	1
15	41291	Plate	1
16	41292	Support	1
17	53179	Screw HHCS M05-0.80 x 20	1
18	44004	Cable Connector	1
19	53362	Nut NHEX 1/2-20 UNF	1
20	41295	Seal Kit	1
21	43369	Check Valve	1
22	42821	Plug	1
23	43370	Orifice	1
24	42553	Hose	1
25	41413	Nut	1

# Hydraulic Hoses and Fittings

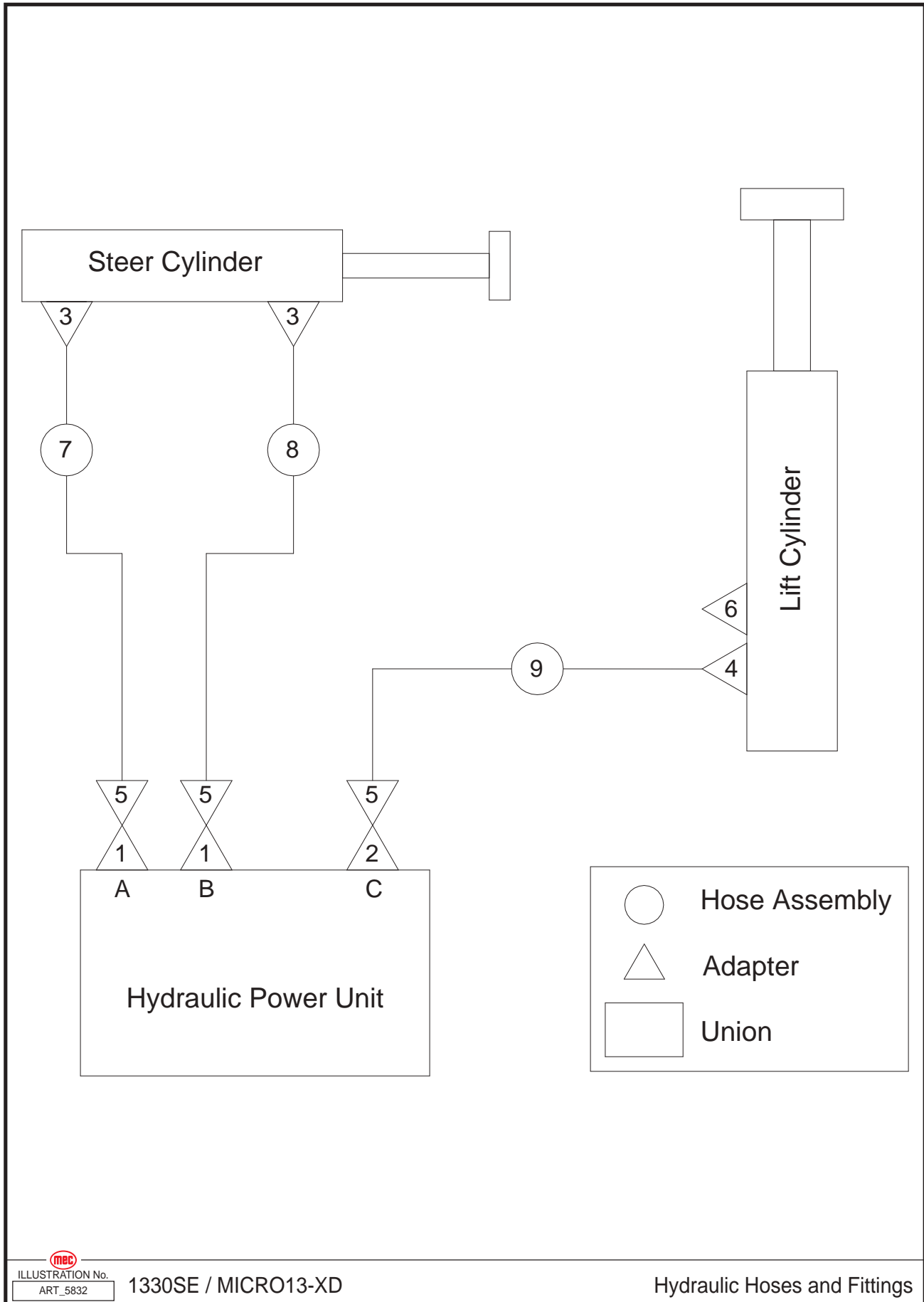

ILLUSTRATION No. ART\_5832

1330SE / MICRO13-XD

Hydraulic Hoses and Fittings



Item	Part Number	Description	Qty.
1	41296	Straight Fitting	2
2	44860	Straight Fitting	1
3	41298	Straight Fitting	2
4	43638	Straight Fitting	1
5	43639	Elbow	3
6	42480	Plug	1
7	42477	Hose Assembly	1
8	44861	Hose Assembly	1
9	44030	Hose Assembly	1

# Electrical Harness, To Serial #16308570

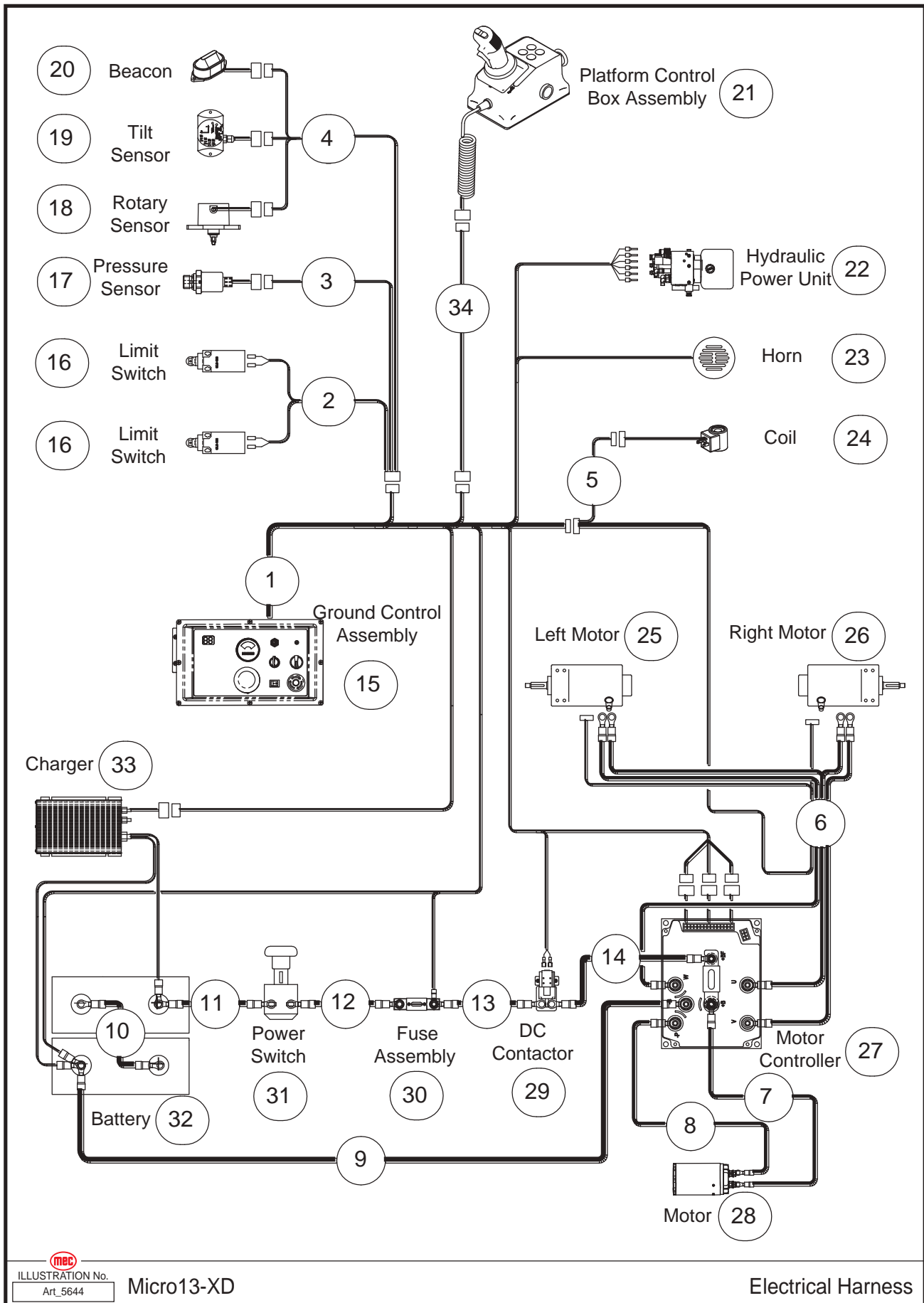

ILLUSTRATION No. **Micro13-XD**  
Art\_5644

Electrical Harness





Item	Part Number	Description	Qty.
1	42481	ECU Harness	1
2	44035	Limit Switch Harness, Pothole	1
3	44862	Pressure Sensor Harness	1
4	41923	Sensor Harness	1
5	44036	Lowering Valve Harness	1
6	42484	Drive Motor Harness	1
7	41921	Pump Motor Positive Harness	1
8	44055	Pump Motor Negative Harness	1
9	42489	Battery Negative Harness	1
10	41920	Battery Harness	1
11	44056	Battery Positive Harness	1
12	41918	Fuse Harness	1
13	44057	DC Contactor Harness	1
14	41917	Motor Controller Harness	1
15	REF	Ground Control Assembly (Refer to page 54)	1
16	REF	Limit Switch, Pothole (Refer to page 56)	2
17	REF	Pressure Sensor (Refer to page 72)	1
18	REF	Rotary Sensor (Refer to page 56)	1
19	REF	Tilt Sensor (Refer to page 56)	1
20	REF	Beacon (Refer to page 56)	1
21	REF	Platform Control Box Assembly (Refer to page 66)	1
22	REF	Hydraulic Power Unit (Refer to page 50)	1
23	REF	Horn (Refer to page 46)	1
24	REF	Coil (Refer to page 72)	1
25	REF	Left Motor (Refer to page 40)	1
26	REF	Right Motor (Refer to page 40)	1
27	REF	Motor Controller (Refer to page 52)	1
28	REF	Motor (Refer to page 50)	1
29	REF	DC Contactor (Refer to page 52)	1
30	REF	150A Fuse Assembly (Refer to page 52)	1
31	REF	Power Switch (Refer to page 54)	1
32	REF	Battery (Refer to page 46)	2
33	REF	Charger (Refer to page 46)	1
34	41922	Harness, Platform Control Box	1

REF - Reference

# Electrical Harness, From Serial #16308571

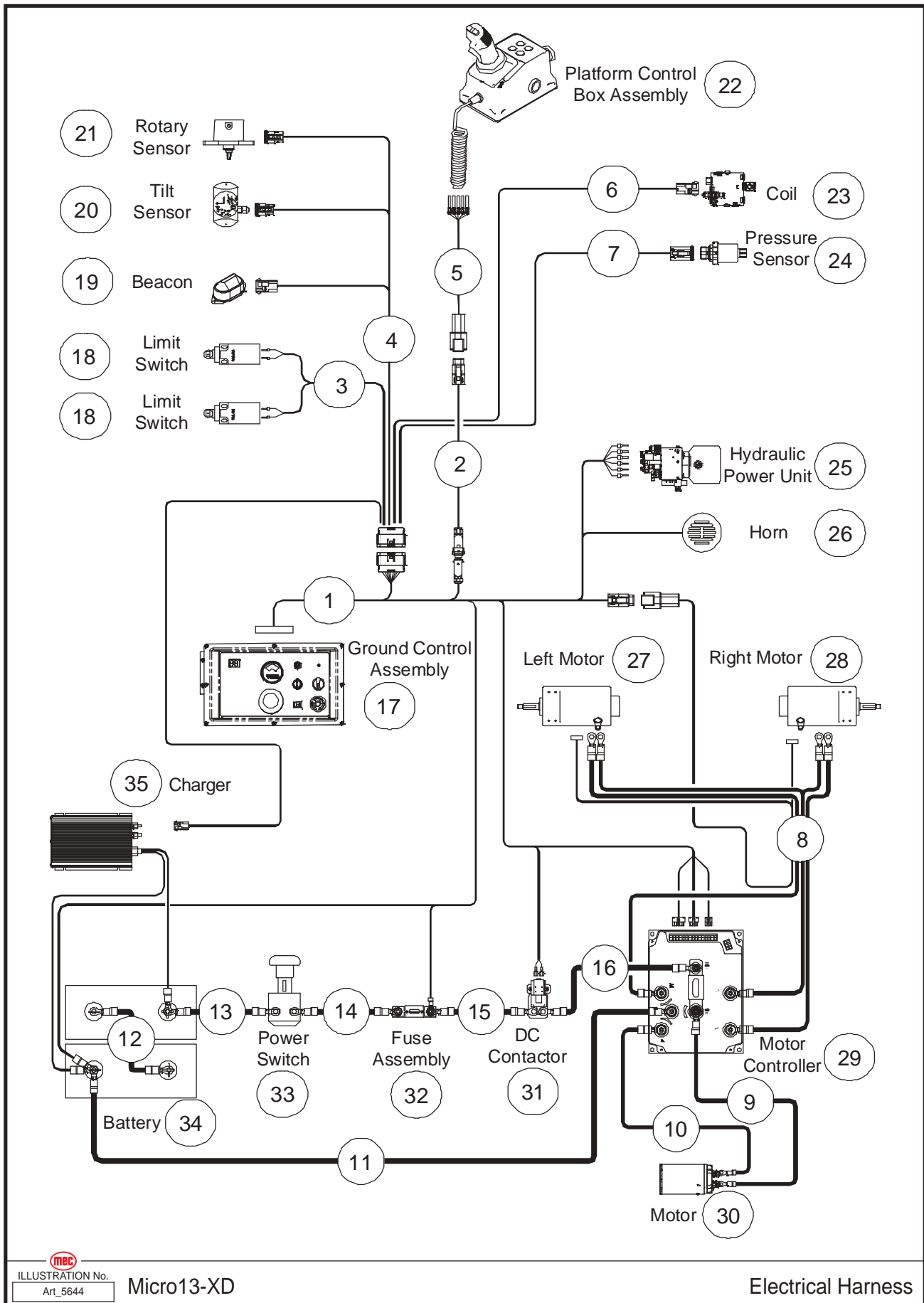

ILLUSTRATION No. **Micro13-XD**  
Art\_5644

Electrical Harness

Item	Part Number	Description	Qty.
1	42481	ECU Harness	1
2	46766	Platform Control Box Patch Cord Harness	1
3	44035	Pothole Limit Switch Harness	1
4	41923	Sensor Harness	1
5	46763	Platform Control Box Harness	1
6	46767	Lift Down Valve Harness	1
7	47276	Pressure Sensor Harness (Matching With 44448 Pressure Sensor)	1
	46768	Pressure Sensor Harness (Matching With 46335 Pressure Sensor)	1
8	46769	Drive Motor Harness	1
9	41921	Pump Motor Positive Harness	1
10	44055	Pump Motor Negative Harness	1
11	42489	Battery Negative Harness	1
12	41920	Battery Harness	1
13	44056	Battery Positive Harness	1
14	41918	Fuse Harness	1
15	44057	DC Contactor Harness	1
16	41917	Motor Controller Harness	1
17	44052	Ground Control Assembly (Refer to page 54)	1
18	41197	Limit Switch	2
19	46264	Beacon	1
20	41098	Tilt Sensor	1
21	41195	Rotary Sensor	1
22	44280	Platform Control Box Assembly	1
23	41929	Coil	1
24	44448	Pressure Sensor (Current Signal)	1
	46335	Pressure Sensor (Voltage Signal)	1
25	46770	Hydraulic Power Unit	1
26	41075	Horn	1
27	43752	Left Motor	1
28	43751	Right Motor	1
29	41610	Motor Controller	1
30	41243	Motor	1
31	41331	DC Contactor	1
32	44031	150A Fuse	1
33	42071	Power Switch	1
34	41330	Battery	2
35	42904	Charger	1

REF - Reference

# Power to Platform

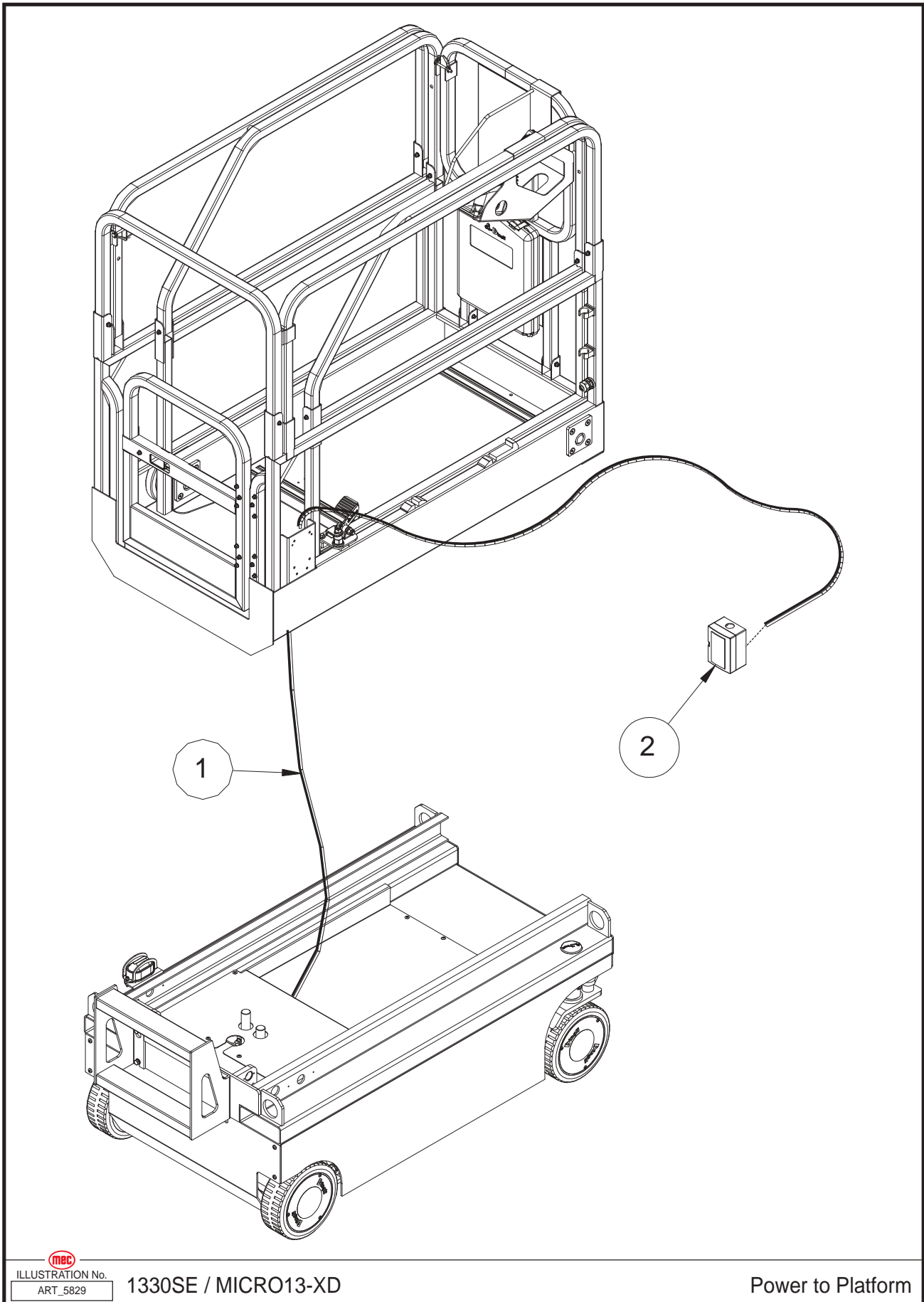

  
ILLUSTRATION No.  
ART\_5829

1330SE / MICRO13-XD

Power to Platform

Item	Part Number	Description	Qty.
1	44034	Wire Cable, Platform AC Power	1
2	91597	Outlet Box	1
--	91598	Outlet Cover	1
--	92007	Outlet, 15A 120V GFCI	1
--	53040	Screw, HHSM #8 x 0.5	4
--	92008	Strain Relief	1

# 900W Inverter

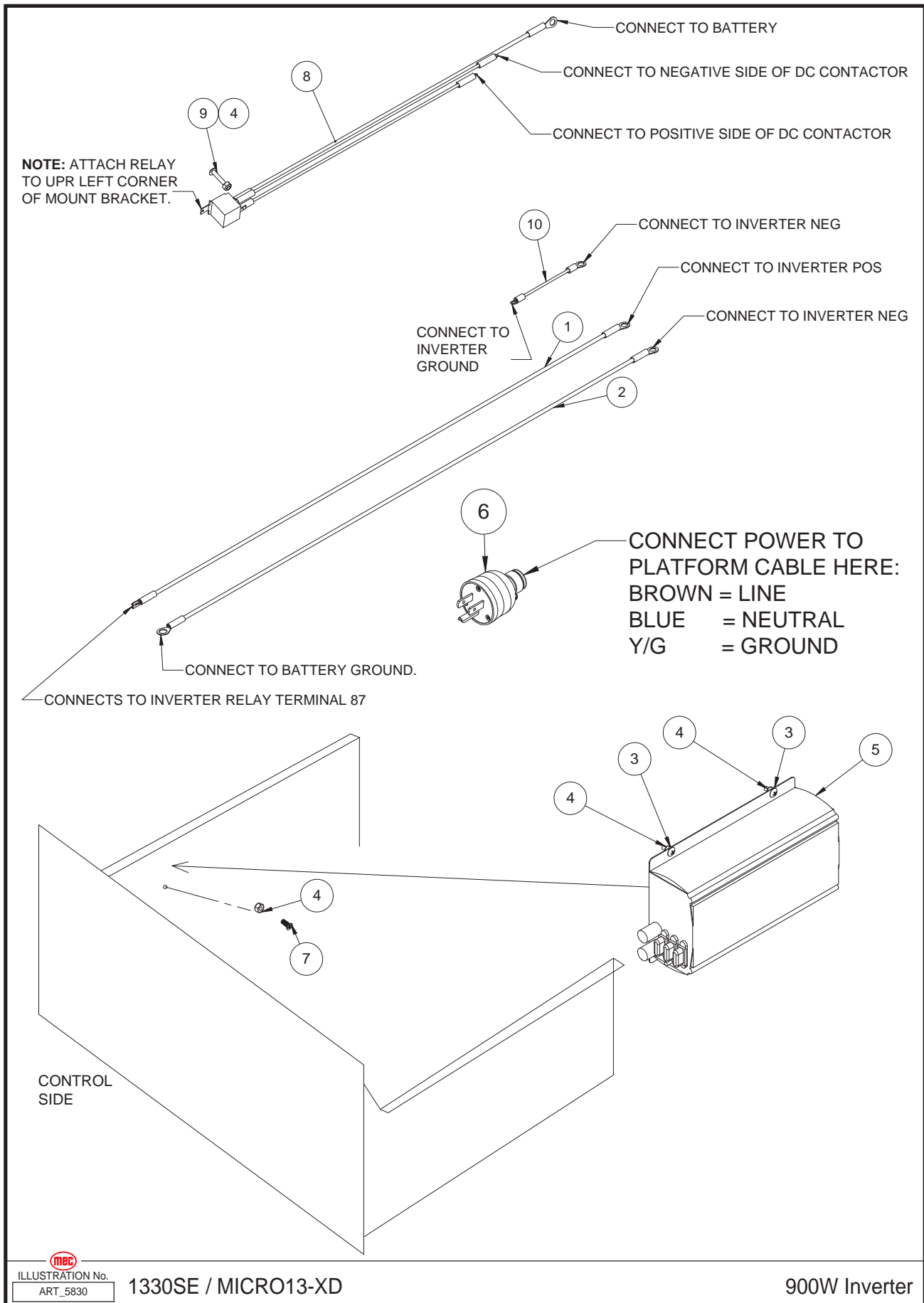

ILLUSTRATION No. ART\_5830

1330SE / MICRO13-XD

900W Inverter



Item	Part Number	Description	Qty.
1	41673	Option, Inverter Positive Cable 1330 & MICRO19	1
2	41674	Option, Inverter Negative Cable 1330 & MICRO19	1
3	50191	THMS #10-32X00.50 ZP	2
4	50238	NNYL #10-32 05 Z	4
5	94359	Power Inverter, 900W 24V DC To AC	1
6	91544	Plug, Male 3 Prong 15 Amp	1
7	53097	FHSC M5-0.8X12MM	1
8	41967	Inverter Relay Assembly	1
9	50330	THMS #10-32X01.00 ZP	1
10	43754	Inverter Option: Ground Cable Ground Cable Jumper	1

# Leak Containment System

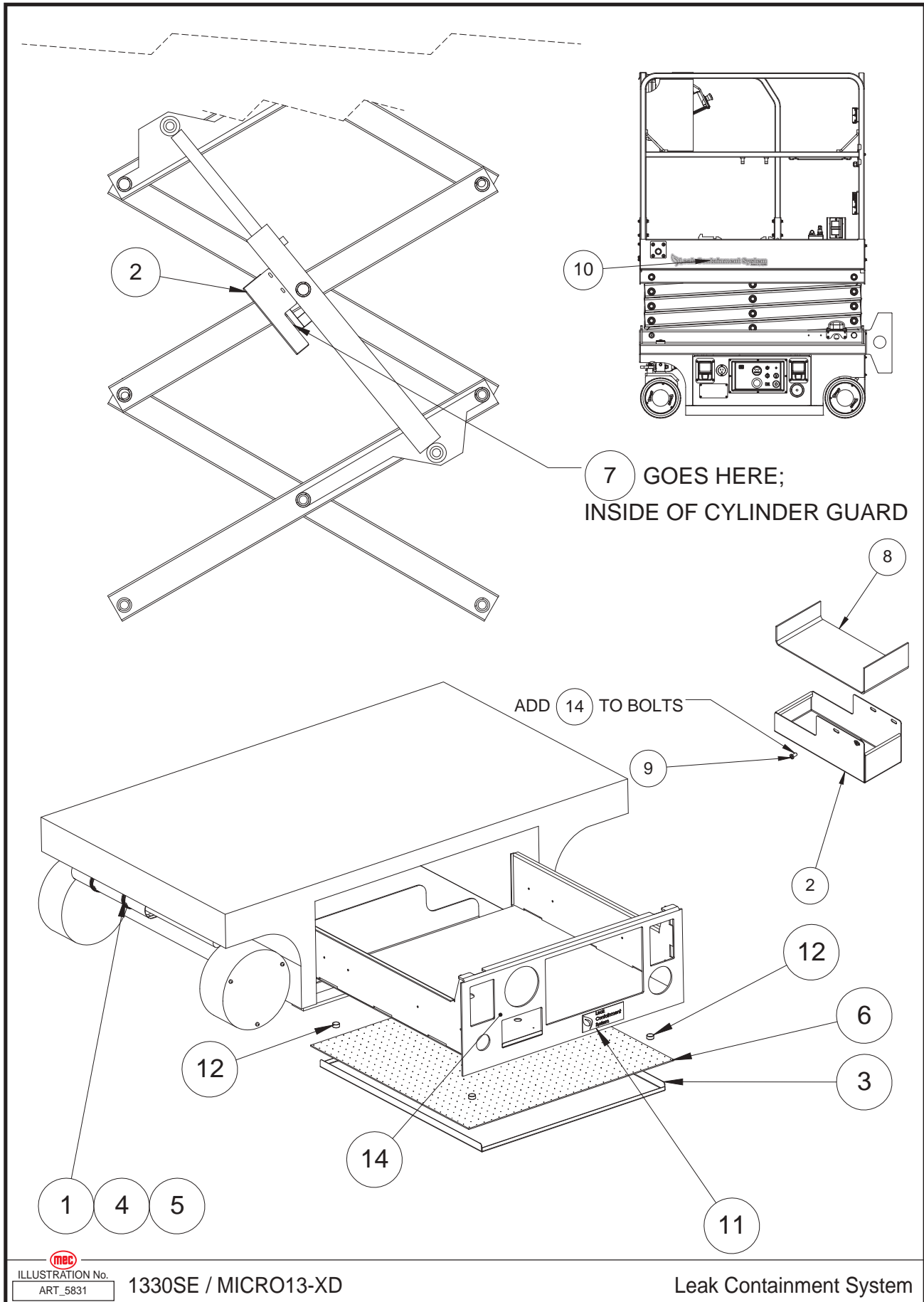

 ILLUSTRATION No. 1330SE / MICRO13-XD  
ART\_5831

Leak Containment System



Item	Part Number	Description	Qty.
1	7545	Clamp Hose #28 1 5/16-2 1/4	2
2	31416	Lower Cylinder Guard	1
3	41994	Oil Containment Forming For 1330	1
4	42897	Hydraulic Cylinder Guard Containment Tray	1
5	42932	Absorbent Pad For Steer Cylinder (Micro19/1330)	1
6	42935	Absorbent Pad For Micro19	1
7	44238	Cylinder Guard Hose Wrap	1
8	44266	Absorbent Pad For LCS Cylinder Guards	1
9	53370	SHCS M6 X 10 Black Oxide Ultra Low Profile	2
10	94866	Leak Containment System, Long Decal	2
11	94867	Leak Containment System, Small Decal	1
12	95048	Magnet 30LB (Max Pull Force)	4
13	95082	Disc Magnet 44LB	1
14	A0005	Loctite 565	REF

REF - Reference

# Decals

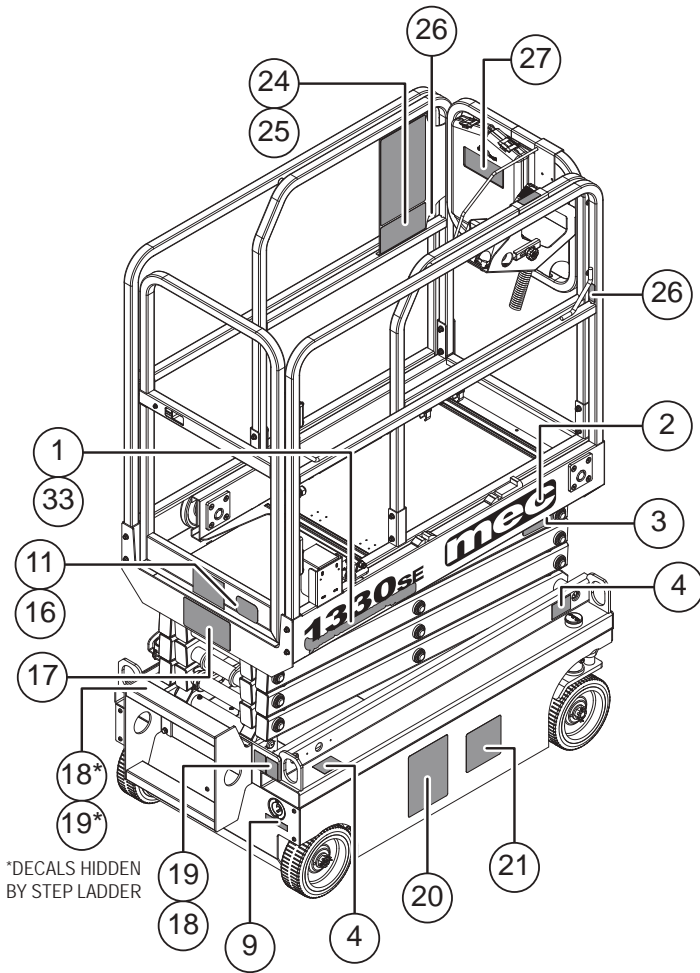

\*DECALS HIDDEN BY STEP LADDER

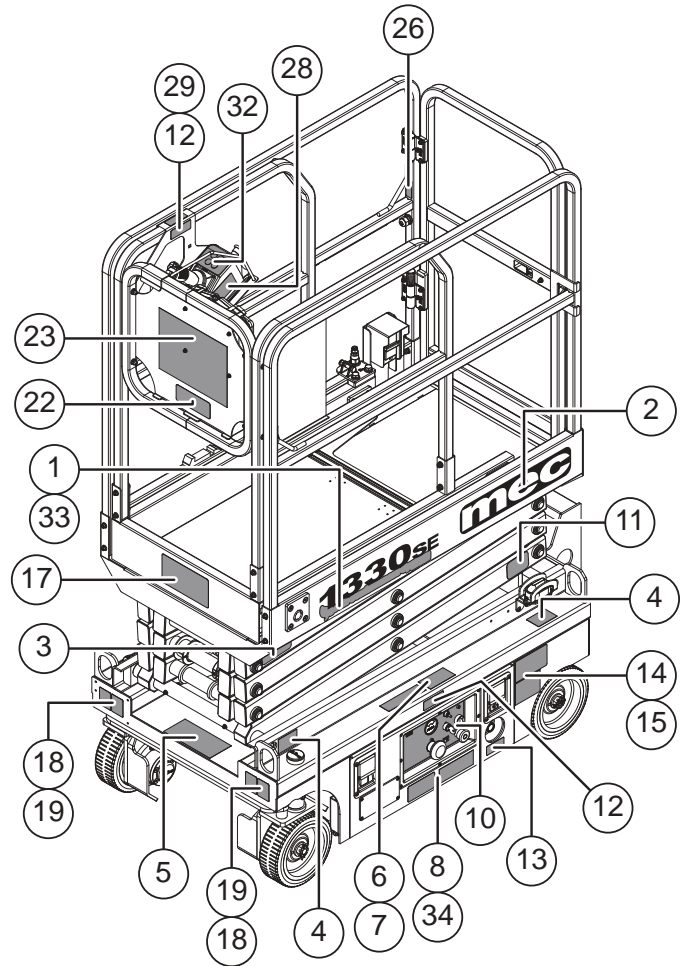



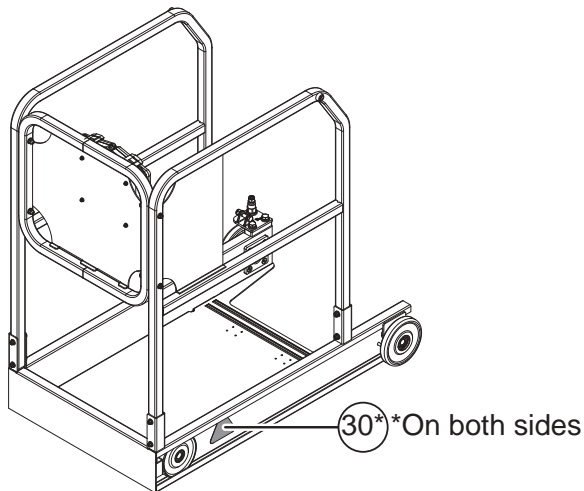



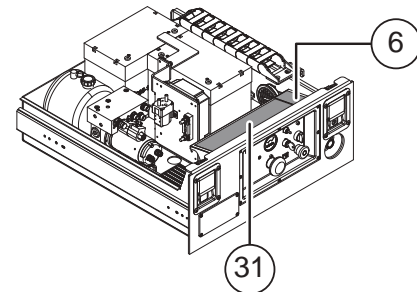



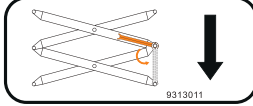

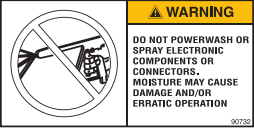

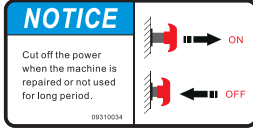

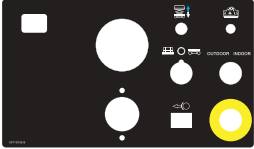

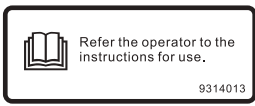
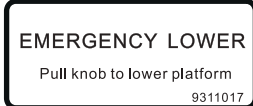

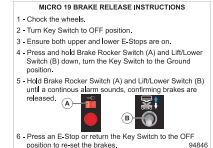

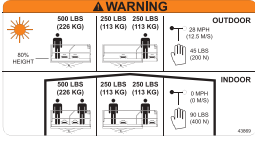







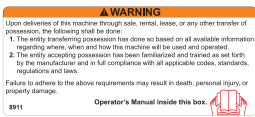

## PLATFORM EXTENDED



## CONTROL MODULE



<p><b>1</b></p>  <p>94116 Qty. - 2</p>	<p><b>2</b></p>  <p>94114 Qty. - 2</p>	<p><b>3</b></p>  <p>41638 Qty. - 2</p>	<p><b>4</b></p>  <p>94362 Qty. - 4</p>	<p><b>5</b></p>  <p>95215 Qty. - 1</p>
<p><b>6</b></p>  <p>90732 Qty. - 2</p>	<p><b>7</b></p>  <p>42534 Qty. - 1</p>	<p><b>8</b></p>  <p>43910 Qty. - 1</p>	<p><b>9</b></p>  <p>94659 Qty. - 1</p>	<p><b>10</b></p>  <p>44442 Qty. - 1</p>
<p><b>11</b></p>  <p>95252 Qty. - 2</p>	<p><b>12</b></p>  <p>41639 Qty. - 2</p>	<p><b>13</b></p>  <p>41636 Qty. - 1</p>	<p><b>14</b></p>  <p>41645 Qty. - 1</p>	<p><b>15</b></p>  <p>94846 Qty. - 1</p>
<p><b>16</b></p>  <p>95301 Qty. - 1</p>	<p><b>17</b></p>  <p>43869 Qty. - 2</p>	<p><b>18</b></p>  <p>41635 Qty. - 4</p>	<p><b>19</b></p>  <p>41634 Qty. - 4</p>	<p><b>20</b></p>  <p>41649 Qty. - 1</p>
<p><b>21</b></p>  <p>41641 Qty. - 1</p>	<p><b>22</b></p>  <p>94423 Qty. - 1</p>	<p><b>23</b></p>  <p>90719 Qty. - 1</p>	<p><b>24</b></p>  <p>41652 Qty. - 1</p>	<p><b>25</b></p>  <p>41647 Qty. - 1</p>
<p><b>26</b></p>  <p>41648 Qty. - 3</p>	<p><b>27</b></p>  <p>8911 Qty. - 1</p>	<p><b>28</b></p>  <p>94528 Qty. - 1</p>	<p><b>29</b></p>  <p>41640 Qty. - 1</p>	<p><b>30</b></p>  <p>91850 Qty. - 2</p>
<p><b>31</b></p>  <p>43879 Qty. - 1</p>	<p><b>32</b></p>  <p>41632 Qty. - 1</p>	<p><b>33</b></p>  <p>94866 Qty. - 2</p>	<p><b>34</b></p>  <p>94867 Qty. - 1</p>	

---

# Notes

---

# Notes





## Limited Owner Warranty

MEC Aerial Platform Sales Corp. warrants its equipment to the original purchaser against defects in material and/or workmanship under normal use and service for one (1) year from date of registered sale or date the unit left the factory if not registered. MEC Aerial Platform Sales Corp. further warrants the structural weldments of the main frame and scissor arms to be free from defects in material or workmanship for five (5) years from date of registered sale or date unit left the factory if not registered. Excluded from such warranty is the battery(s) which carries a ninety (90) day warranty from described purchase date. Warranty claims within such warranty period shall be limited to repair or replacement, MEC Aerial Platform Sales Corp's option, of the defective part in question and labor to perform the necessary repair or replacement based on MEC Aerial Platform Sales Corp's then current flat rate, provided the defective part in question is shipped prepaid to MEC Aerial Platform Sales Corp. and is found upon inspection by MEC Aerial Platform Sales Corp. to be defective in material and/or workmanship. MEC Aerial Platform Sales Corp. shall not be liable for any consequential, incidental or contingent damages whatsoever. Use of other than factory authorized parts; misuse, improper maintenance, or modification of the equipment voids this warranty. The foregoing warranty is exclusive and in lieu of all other warranties, express or implied. All such other warranties, including implied warranties of merchantability and of fitness for a particular purpose, are hereby excluded. No Dealer, Sales Representative, or other person purporting to act on behalf of MEC Aerial Platform Sales Corp. is authorized to alter the terms of this warranty, or in any manner assume on behalf of MEC Aerial Platform Sales Corp. any liability or obligation which exceeds MEC Aerial Platform Sales Corp's obligations under this warranty.



# MEC Aerial Work Platforms

---

1401 S. Madera Avenue, Kerman, CA 93630 USA

Toll Free: 1-877-632-5438

Phone: 1-559-842-1500

Fax: 1-559-842-1520

[info@MECawp.com](mailto:info@MECawp.com)

[www.MECawp.com](http://www.MECawp.com)