

Hydraulic Unit

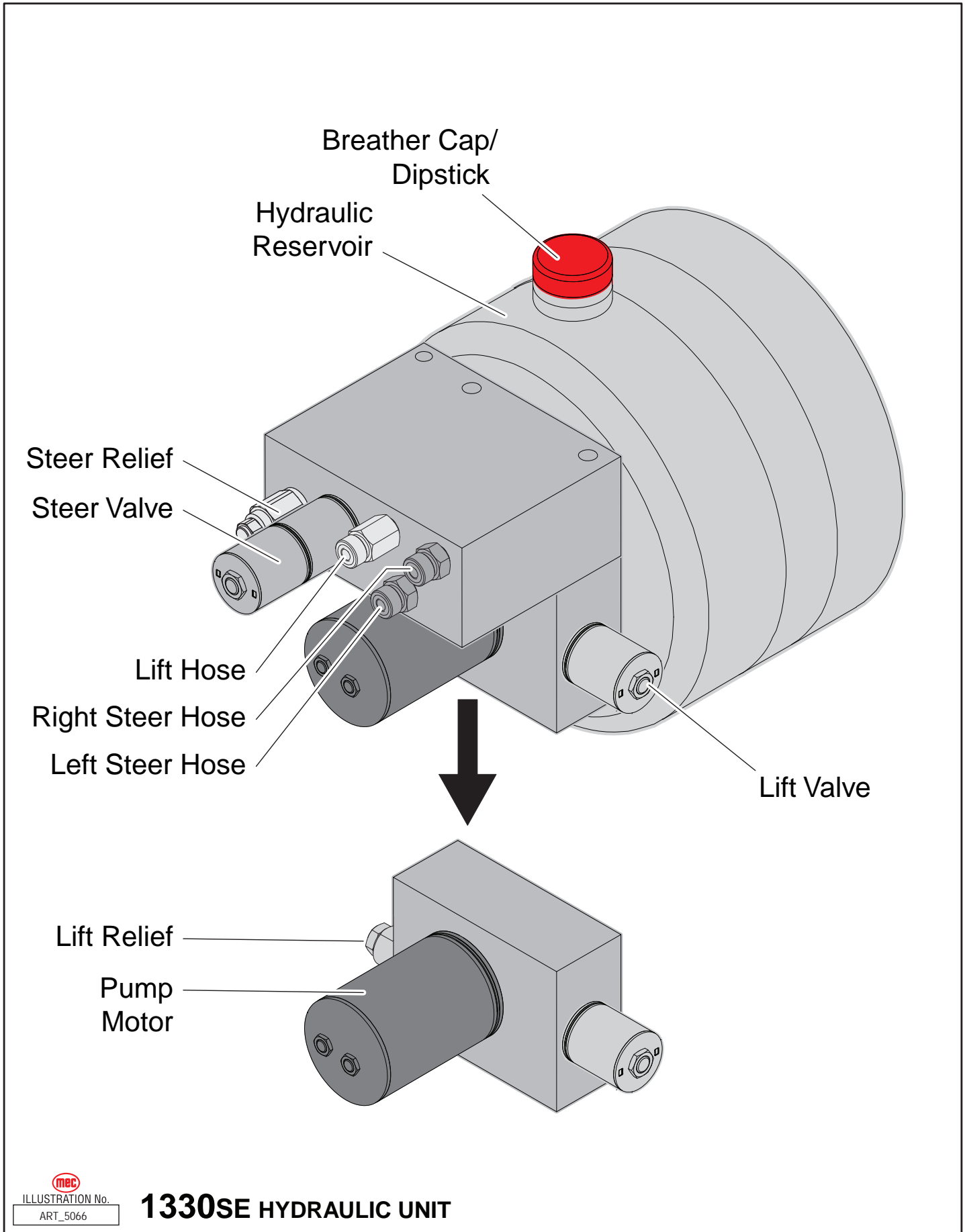
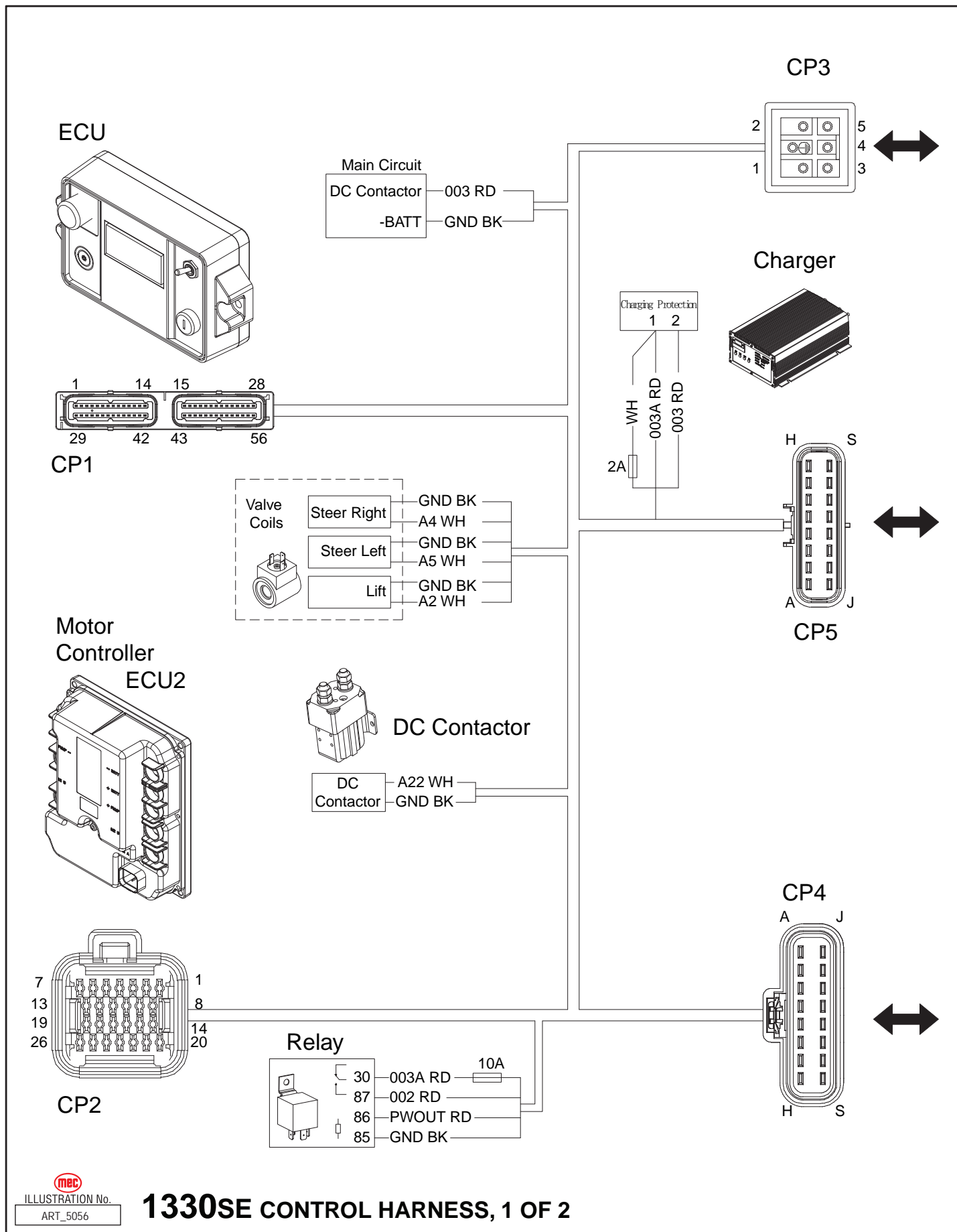



ILLUSTRATION No.
ART_5066

1330SE HYDRAULIC UNIT

Control Harness, 1 Of 2



mec
ILLUSTRATION No.
ART_5056

1330SE CONTROL HARNESS, 1 OF 2



Control Harness, 2 Of 2

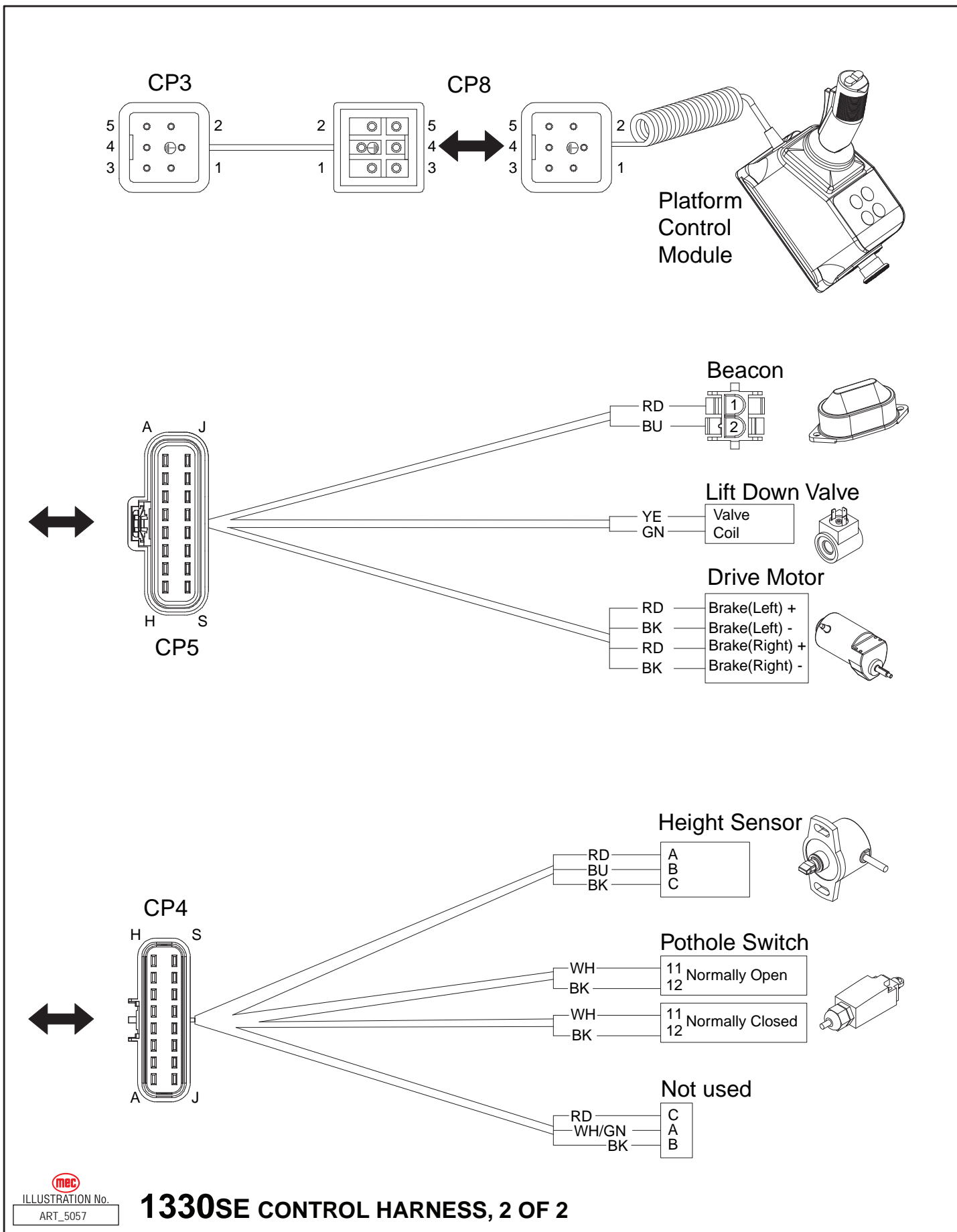

MEC
ILLUSTRATION No.
ART_5057

1330SE CONTROL HARNESS, 2 OF 2



Pin Identification, ECU Harness Plug

ECU

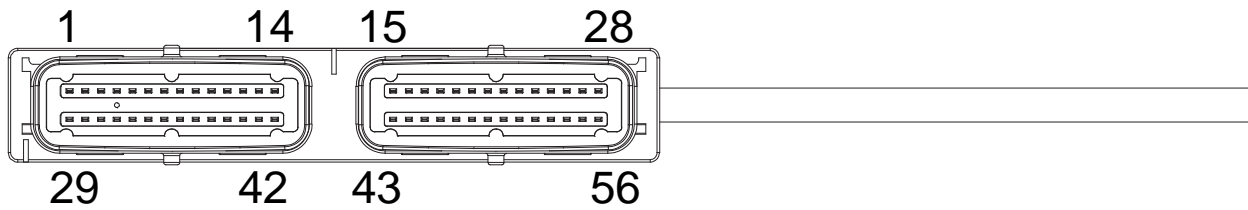
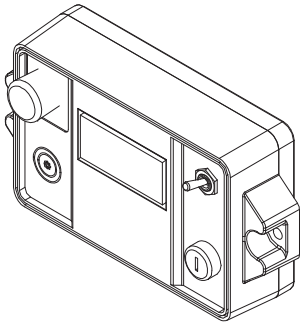

Pin #	ID	Color	Place	Pin #	ID	Color	Place
1	A1	WH	Lift Down Valve	29	A29	WH	Pothole Switch
2	A2	WH	Lift Up Valve	30	/	/	/
3	A3	WH	Power Key	31	A31	WH	Power Key
4	A4	WH	Steer Right Valve	32	A32	WH	Anti-Collision Switch
5	A5	WH	Steer Left Valve	33	A33	WH	TLT Sensor
6	/	/	/	34	A34	WH	Pedal Switch
7	A7	WH	Indoor/Outdoor Switch	35	/	/	/
8	/	/	/	36	/	/	/
9	/	/	/	37	/	/	/
10	A10	BK	Ground	38	/	/	/
11	/	/	/	39	/	/	/
12	A12	GN	CAN_L	40	A40	YE	CAN_H
13	/	/	/	41	A41	RD	Power
14	A14	RD	Power	42	A42	RD	Power
15	A15	RD	Power	43	A43	RD	Power
16	/	/	/	44	A44	RD	Power
17	A17	WH	Horn	45	A45	WH	Pressure Sensor
18	A18	WH	Beacon	46	A46	WH	Pressure Sensor
19	A19	WH	TM-Main Contactor	47	/	/	/
20	A20	WH	TM-Brake	48	A48	WH	Potentiometer
21	/	/	/	49	/	/	/
22	A22	WH	Main Contactor Coil	50	/	/	/
23	A23	WH	TM-Motor (Right) Feedback	51	/	/	/
24	A24	WH	TM-Motor (Left) Feedback	52	A52	GY	PCU Power
25	A25	WH	Left Motor Brake Coil	53	A53	GY	PCU Power
26	A26	WH	Right Motor Brake Coil	54	A54	BK	Ground
27	A27	RD	Power	55	A55	BK	Ground
28	A28	BK	Ground	56	A56	BK	Ground



ILLUSTRATION No.
ART_5058

1330SE PIN IDENTIFICATION, ECU HARNESS PLUG



Pin Identification, Motor Controller ECU2 Harness Plug

Motor
Controller
ECU2

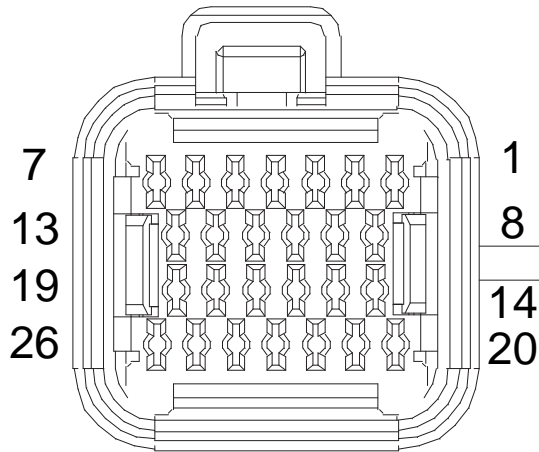
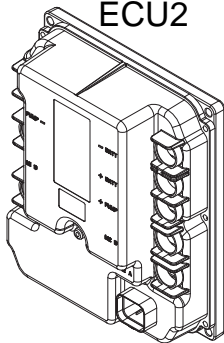

Pin #	ID	Color	Place	Pin #	ID	Color	Place
1	A23	WH	ECU	14	GND	BK	Ground
2	A24	WH	ECU	15	GND	BK	Ground
3	/	/	/	16	GND	BK	Ground
4	/	/	/	17	/	/	/
5	CANL	GN	ECU	18	/	/	/
6	CANL	GN	ECU	19	/	/	/
7	CANH	YE	ECU	20	/	/	/
8	002	RD	Power	21	/	/	/
9	002	RD	Power	22	/	/	/
10	002	RD	Power	23	A20	WH	ECU
11	/	/	/	24	A24	WH	ECU
12	/	/	/	25	A25	WH	ECU
13	/	/	/	26	/	/	/



ILLUSTRATION No.
ART_5059

1330SE PIN IDENTIFICATION, MOTOR CONTROLLER (ECU2) HARNESS PLUG



Pin Identification, Main Harness Plugs

Pin #	ID	Color	Place
1	A52	GY	ECU
2	PWOUT	RD	Relay
3	GND	BK	Ground
4	CANH	YE	ECU
5	CANL	GN	ECU

To Platform Controls

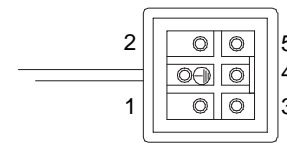

To Beacon,
Lift Down Valve,
Drive Motors

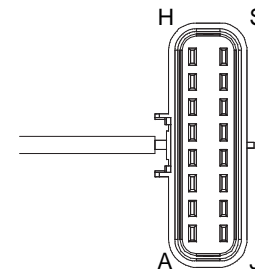

Pin #	ID	Color	Place	Pin #	ID	Color	Place
A	002	RD	POWER	J	GND	BK	GROUND
B	002	RD	POWER	K	GND	BK	GROUND
C	A1	WH	ECU	L	GND	BK	GROUND
D	A25	WH	ECU	M	GND	BK	GROUND
E	A26	WH	ECU	N	/	/	/
F	A17	WH	ECU	P	/	/	/
G	A18	WH	ECU	R	/	/	/
H	GND	BK	GROUND	S	/	/	/

To Height Sensor,
Pothole Switch

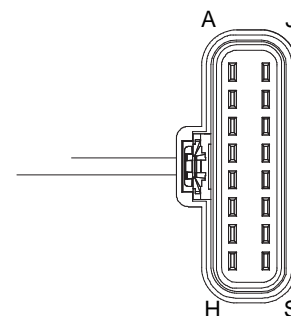

Pin #	ID	Color	Place	Pin #	ID	Color	Place
A	002	RD	POWER	J	A32	WH	ECU
B	002	RD	POWER	K	A33	WH	ECU
C	002	RD	POWER	L	A45	WH	ECU
D	002	RD	POWER	M	A46	WH	ECU
E	002	RD	POWER	N	A48	WH	ECU
F	A29	WH	ECU	P	GND	BK	GROUND
G	A7	WH	ECU	R	GND	BK	GROUND
H	A34	WH	ECU	S	GND	BK	GROUND



ILLUSTRATION No.
ART_5060

1330SE PIN IDENTIFICATION, MAIN HARNESS PLUGS



Pin Identification, Platform Controls, COM Cable

Pin #	Color
1	RD
2	GN
3	WH
4	YE
5	BU

Pin #	Color
1	RD
2	GN
3	WH
4	YE
5	BU

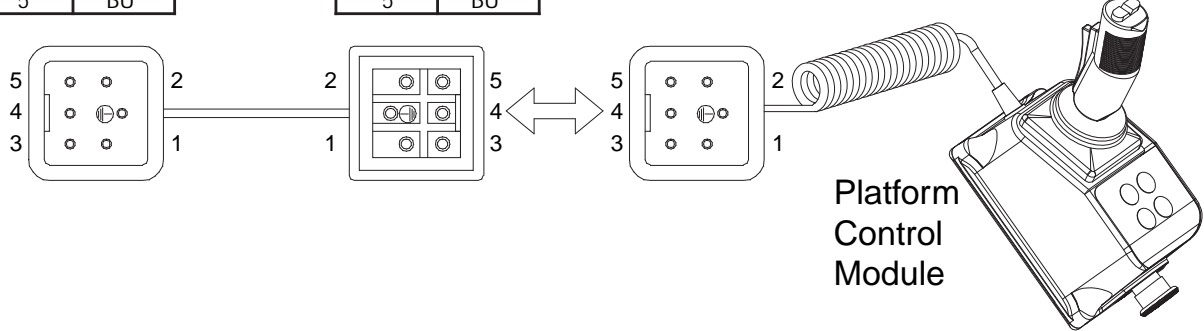

ILLUSTRATION No.
ART_5061

1330SE PIN IDENTIFICATION, PLATFORM CONTROLS/COM CABLE



Pin Identification, Chassis Connections

Pin #	Color	Place	Pin #	Color	Place
A	/	/	J	BK	BRAKE (LEFT)
B	/	/	K	BK	BRAKE (RIGHT)
C	YE	LIFT DOWN VALVE	L	GN	LIFT DOWN VALVE
D	RD	BRAKE (LEFT)	M	/	/
E	RD	BRAKE (RIGHT)	N	/	/
F	/	/	P	/	/
G	RD	BEACON	R	/	/
H	BU	BEACON	S	/	/

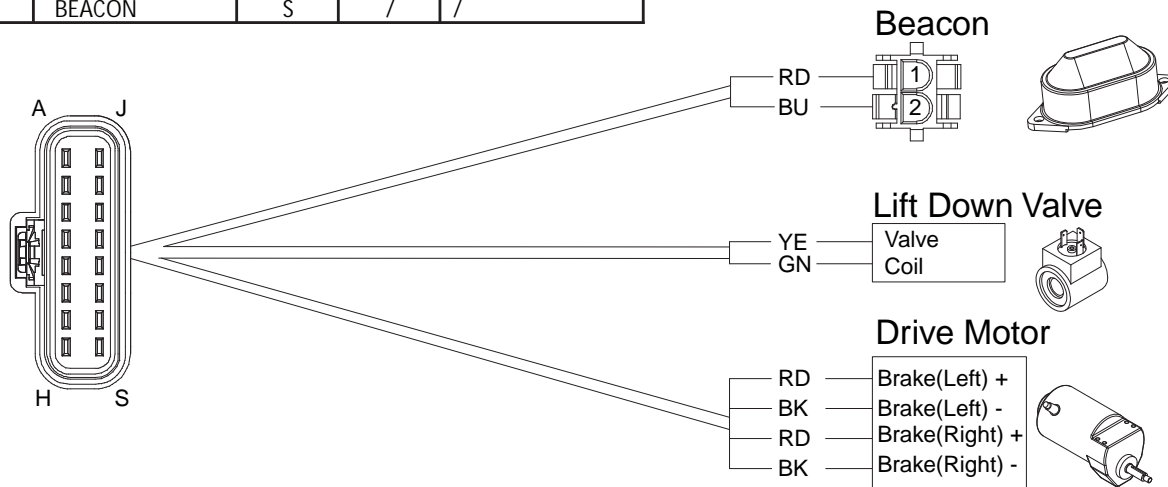

Pin #	Color	Place	Pin #	Color	Place
A	/	/	J	/	/
B	/	/	K	/	/
C	RD	PRESSURE SWITCH	L	WH	PRESSURE SWITCH
D	RD	HEIGHT SENSOR	M	GN	PRESSURE SWITCH
E	WH	POTHOLE SWITCH	N	YE	HEIGHT SENSOR
F	WH	POTHOLE SWITCH	P	BK	HEIGHT SENSOR
G	/	/	R	/	/
H	/	/	S	BK	PRESSURE SENSOR

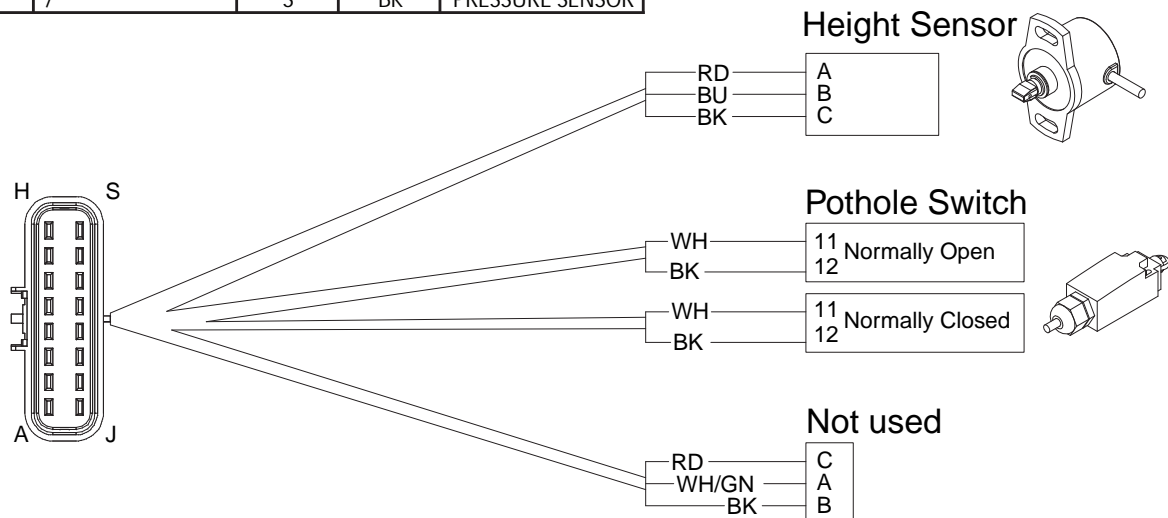

mec
ILLUSTRATION No.
ART_5062

1330SE PIN IDENTIFICATION, CHASSIS CONNECTIONS



Wiring Diagram

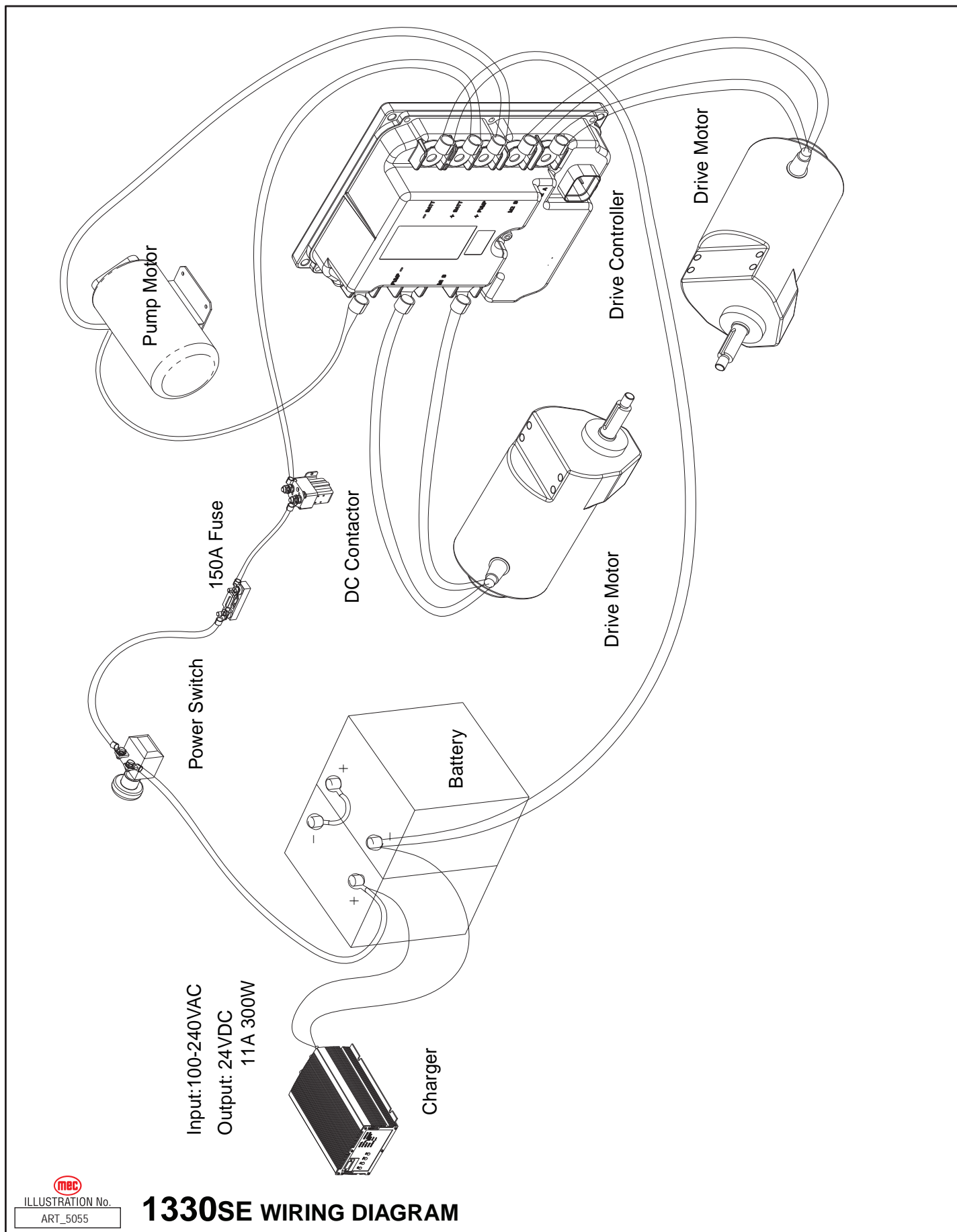



ILLUSTRATION No.
ART_5055

1330SE WIRING DIAGRAM