

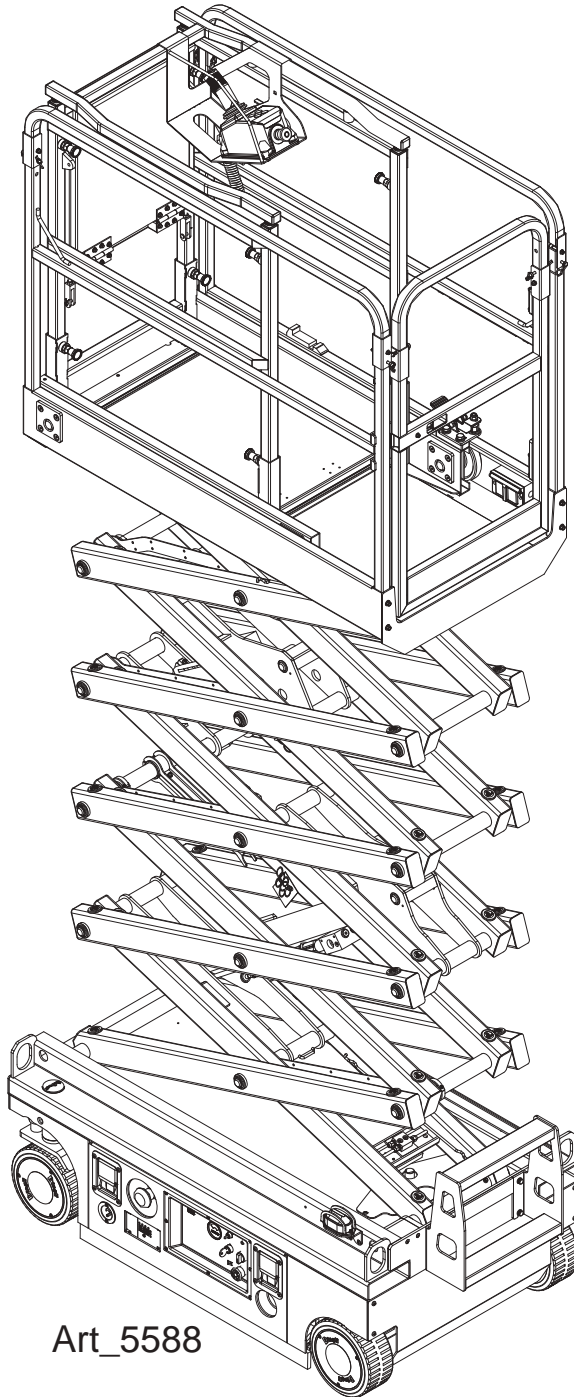

# Service & Parts Manual

## Micro19-XD



Art\_5588

Meets requirements of ANSI A92.20-2020 and CSA B354.6-2019.  
Serial Number Range 1610000 - Up

Part # 43894  
August 2024

## Revision History

Date	Reason for Update
June 2020	New Release
August 2023	Added new style Drive Wheel Assembly with serial numbers Added new style Steer Linkage and Wheels Assembly with serial numbers
August 2024	Updated Calibrate Height instructions



# MEC Aerial Work Platforms

---

1401 S. Madera Avenue, Kerman, CA 93630 USA  
Toll Free: 1-877-632-5438  
Phone: 1-559-842-1500  
Fax: 1-559-842-1520  
info@MECawp.com  
www.MECawp.com

# Table of Contents

Chapter 1 - Service . . . . .	1
<i>Service Introduction</i> . . . . .	1
<b>Section 1 - MEC Operator Policy</b> . . . . .	<b>2</b>
<i>MEC Operator Policy</i> . . . . .	2
<b>Section 2 - Safety Symbols &amp; General Safety Tips</b> . . . . .	<b>3</b>
<i>Safety Symbols &amp; General Safety Tips</i> . . . . .	3
<b>Section 3 - Torque Specifications</b> . . . . .	<b>4</b>
<i>Bolt Torque Specification - American Standard</i> . . . . .	4
<i>Bolt Torque Specification - Metric Standard</i> . . . . .	5
<i>Hydraulic Components Torque Table</i> . . . . .	6
<b>Section 4 - Specifications</b> . . . . .	<b>7</b>
<i>Specifications</i> . . . . .	7
<b>Section 5 - Maintenance Lock</b> . . . . .	<b>8</b>
<i>Maintenance Lock</i> . . . . .	8
<b>Section 6 - Machine Systems</b> . . . . .	<b>9</b>
<i>Machine Systems</i> . . . . .	9
<b>Section 7 - Primary Machine Components.</b> . . . . .	<b>10</b>
<i>Primary Machine Components</i> . . . . .	10
<b>Section 8 - Emergency Systems and Procedures.</b> . . . . .	<b>11</b>
<i>Emergency Systems and Procedures</i> . . . . .	11
<b>Section 9 - Transport and Lifting Instructions.</b> . . . . .	<b>12</b>
<i>Free-Wheel Configuration for Winching or Towing</i> . . . . .	12
<i>Lift and Support the Machine</i> . . . . .	13
<b>Section 10 - Maintenance</b> . . . . .	<b>14</b>
<i>General Machine Maintenance</i> . . . . .	14
<i>Pre-Start Inspection Checklist</i> . . . . .	16
<i>Frequent Inspection Checklist</i> . . . . .	17
<i>Annual Inspection Checklist</i> . . . . .	23
<i>Maintenance Inspection Report</i> . . . . .	26
<b>Section 11 - Control System</b> . . . . .	<b>27</b>
<i>Control Component Locations</i> . . . . .	27
<i>Fault Codes</i> . . . . .	28
<i>Error Indicator Readout</i> . . . . .	29
<b>Section 12 - Calibration</b> . . . . .	<b>32</b>
<i>Calibration Instructions</i> . . . . .	32

<b>Section 13 - Schematics</b>	<b>35</b>
<i>Electrical Schematic</i>	35
<i>Hydraulic Schematic</i>	36
<i>Hydraulic Cap</i>	37
Chapter 2 - Parts	39
<b>Section 14 - Chassis.</b>	<b>40</b>
<i>Steer Linkage and Wheels Assembly, To Serial #16102681</i>	40
<i>Drive Wheel Assembly, To Serial #16102681</i>	42
<i>Steer Linkage and Wheels Assembly, From Serial #16102682</i>	44
<i>Drive Wheel Assembly, From Serial #16102682</i>	46
<i>Pothole Protection Assembly</i>	48
<i>Battery Pack Module</i>	50
<i>Hydraulic Power Unit</i>	52
<i>Motor Controller Assembly</i>	54
<i>Ground Control Assembly</i>	56
<i>Ladder and Accessories</i>	58
<b>Section 15 - Scissor</b>	<b>60</b>
<i>Scissor Assembly</i>	60
<b>Section 16 - Platform</b>	<b>64</b>
<i>Main Platform Assembly, Folding Rails</i>	64
<i>Main Platform Assembly, Fixed Rails</i>	66
<i>Platform Extension Assembly, Old Style</i>	68
<i>Platform Extension Assembly, New Style</i>	70
<i>Platform Control Assembly</i>	72
<i>Platform Control Box Assembly</i>	74
<i>Platform Locking Device Assembly</i>	76
<i>Step Installation</i>	78
<b>Section 17 - Hydraulic System</b>	<b>80</b>
<i>Lower Lift Cylinder Assembly</i>	80
<i>Upper Lift Cylinder Assembly</i>	82
<i>Hydraulic Hoses and Fittings</i>	84
<b>Section 18 - Electrical System</b>	<b>86</b>
<i>Electrical Harness</i>	86
<i>Power to Platform</i>	88
<b>Section 19 - Decals</b>	<b>90</b>
<i>Decals</i>	90

---

## Service Introduction

This Service section is designed to provide you, the customer, with the instructions needed to properly maintain the MEC self-propelled aerial work platform. When used in conjunction with the illustrated Parts section in this manual and the Operator's Manual (provided separately), this manual will assist you in making necessary adjustments and repairs, and identifying and ordering the correct replacement parts.

All parts represented here are manufactured and supplied in accordance with MEC quality standards. We recommend that you use genuine MEC parts to ensure proper operation and reliable performance.

To obtain maximum benefits from your MEC Aerial Work Platforms, always follow the proper operating and maintenance procedures. Only trained authorized personnel should be allowed to operate or service this machine. Service personnel should read and study the Operator's, and the Service and Parts Manuals in order to gain a thorough understanding of the unit prior to making any repairs.

## MEC Operator Policy

**Note:** *The best method to protect yourself and others from injury or death is to use common sense. If you are unsure of any operation, **don't start** until you are satisfied that it is safe to proceed and have discussed the situation with your supervisor.*

Service personnel and machine operators must understand and comply with all warnings and instructional decals on the body of the machine, at the ground controls, and platform control console.



**MODIFICATIONS OF THIS MACHINE FROM THE ORIGINAL DESIGN AND SPECIFICATIONS WITHOUT WRITTEN PERMISSION FROM MEC ARE STRICTLY FORBIDDEN. A MODIFICATION MAY COMPROMISE THE SAFETY OF THE MACHINE, SUBJECTING OPERATOR(S) TO SERIOUS INJURY OR DEATH.**

MEC's policies and procedures demonstrate our commitment to Quality and our relentless ongoing efforts towards Continuous Improvement, due to which product specifications are subject to change without notice.

Any procedures not found within this manual must be evaluated by the individual to assure oneself that they are "proper and safe."

Your MEC Aerial Work Platform has been designed, built, and tested to provide many years of safe, dependable service. Only trained, authorized personnel should be allowed to operate or service the machine.

MEC, as manufacturer, has no direct control over machine application and operation. Proper safety practices are the responsibility of the user and all operating personnel.

**If there is a question on application and/or operation, contact MEC Aerial Work Platforms:**



## MEC Aerial Work Platforms

1401 S. Madera Avenue, Kerman, CA 93630 USA  
Toll Free: 1-877-632-5438  
Phone: 1-559-842-1500  
Fax: 1-559-842-1520  
info@MECawp.com  
www.MECawp.com

## Safety Symbols & General Safety Tips

MEC manuals and decals use symbols, colors and signal words to help you recognize important safety, operation and maintenance information.



**RED and the word DANGER** – Indicates an imminently hazardous situation which, if not avoided, will result in death or serious injury.



**ORANGE and the word WARNING** – Indicates a potentially hazardous situation which, if not avoided, could result in death or serious injury.



**YELLOW with alert symbol and the word CAUTION** – Indicates a potentially hazardous situation which, if not avoided, may result in minor or moderate injury.



**YELLOW without alert symbol and the word CAUTION** – Indicates a potentially hazardous situation which, if not avoided, may result in property damage.



**GREEN and the word NOTICE** – Indicates operation or maintenance information.

Regular inspection and constant maintenance is the key to efficient economical operation of your aerial work platform. It will help to assure that your equipment will perform satisfactorily with a minimum of service and repair.



The actual operating environment of the machine governs the inspection schedule. Correct lubrication is an essential part of the preventative maintenance to minimize wear on working parts and ensure against premature failure. By maintaining correct lubrication, the possibility of mechanical failure and resulting downtime is reduced to a minimum.

- Never leave hydraulic components or hoses open. They must be protected from contamination (including rain) at all times.
- Never open a hydraulic system when there are contaminants in the air.
- Always clean the surrounding area before opening hydraulic systems.
- Use only recommended lubricants. Improper lubricants or incompatible lubricants may be as harmful as no lubrication.
- Watch for makeshift “fixes” which can jeopardize safety as well as lead to more costly repair.

## Bolt Torque Specification - American Standard

### Fasteners

Use the following values to apply torque unless a specific torque value is called out for the part being used.

American Standard Cap Screws								
SAE Grade	5				8			
Cap Screw Size (Inches)								
	Torque				Torque			
	Ft-lbs		Nm		Ft-lbs		Nm	
	Min	Max	Min	Max	Min	Max	Min	Max
1/4 - 20	6.25	7.25	8.5	10	8.25	9.5	11	13
1/4 - 28	8	9	11	12	10.5	12	14	16
5/16 - 18	14	15	19	20	18.5	20	25	27
5/16 - 24	17.5	19	12	26	23	25	31	34
3/8 - 16	26	28	35	38	35	37	47.5	50
3/8 - 24	31	34	42	46	41	45	55.5	61
7/16 - 14	41	45	55.5	61	55	60	74.5	81
7/16 - 20	51	55	69	74.5	68	75	92	102
1/2 - 13	65	72	88	97.5	86	96	116	130
1/2 - 20	76	84	103	114	102	112	138	152
9/16 - 12	95	105	129	142	127	140	172	190
9/16 - 18	111	123	150	167	148	164	200	222
5/8 - 11	126	139	171	188	168	185	228	251
5/8 - 18	152	168	206	228	203	224	275	304
3/4 - 10	238	262	322	255	318	350	431	474
3/4 - 16	274	302	371	409	365	402	495	544
7/8 - 9	350	386	474	523	466	515	631	698
7/8 - 14	407	448	551	607	543	597	736	809
1 - 8	537	592	728	802	716	790	970	1070
1 - 14	670	740	908	1003	894	987	1211	1137

Torque values apply to fasteners as received from the supplier, dry or when lubricated with normal engine oil.





If special graphite grease, molydisulphide grease, or other extreme pressure lubricants are used, these torque values do not apply.



## Bolt Torque Specification - Metric Standard

### Fasteners

Use the following values to apply torque unless a specific torque value is called out for the part being used.

Metric Cap Screws								
Metric Grade	8.8				10.9			
Cap Screw Size (Millimeters)								
	Torque				Torque			
	Ft-lbs		Nm		Ft-lbs		Nm	
	Min	Max	Min	Max	Min	Max	Min	Max
<b>M6 × 1.00</b>	6	8	8	11	9	11	12	15
<b>M8 × 1.25</b>	16	20	21.5	27	23	27	31	36.5
<b>M10 × 1.50</b>	29	35	39	47	42	52	57	70
<b>M12 × 1.75</b>	52	62	70	84	75	91	102	123
<b>M14 × 2.00</b>	85	103	115	139	120	146	163	198
<b>M16 × 2.50</b>	130	158	176	214	176	216	238	293
<b>M18 × 2.50</b>	172	210	233	284	240	294	325	398
<b>M20 × 2.50</b>	247	301	335	408	343	426	465	577
<b>M22 × 2.50</b>	332	404	450	547	472	576	639	780
<b>M24 × 3.00</b>	423	517	573	700	599	732	812	992
<b>M27 × 3.00</b>	637	779	863	1055	898	1098	1217	1488
<b>M30 × 3.00</b>	872	1066	1181	1444	1224	1496	1658	2027

Torque values apply to fasteners as received from the supplier, dry or when lubricated with normal engine oil.

If special graphite grease, molydisulphide grease, or other extreme pressure lubricants are used, these torque values do not apply.

## Hydraulic Components Torque Table

**Note:** Always lubricate threads with clean hydraulic fluid prior to installation.

Use the following values to torque hydraulic components when a specific value is not available. Always check for torque values in the following places before relying on the Hydraulic Components Torque Table.

- Parts drawings and service instructions in this manual.
- Packaging and instruction sheets provided with new parts.
- Instruction manuals provided by the manufacturer of the component being serviced.

SAE Port Series	Cartridge Poppet		Fittings		Hoses	
	Ft-lbs	Nm	Ft-lbs	Nm	In-lbs	Nm
#4	N/A	N/A	N/A	N/A	135 - 145	15 - 16
#6	N/A	N/A	10 - 20	14 - 27	215 - 245	24 - 28
#8	25 - 30	31 - 41	25 - 30	34 - 41	430 - 470	49 - 53
#10	35 - 40	47 - 54	35 - 40	47 - 54	680 - 750	77 - 85
#12	85 - 90	115 - 122	85 - 90	115 - 122	950 - 1050	107 - 119
#16	130 - 140	176 - 190	130 - 140	176 - 190	1300 - 1368	147 - 155

# Specifications

Working Height*	Indoor	24.4 ft	7.43 m
	Outdoor	19 ft	5.79 m
Platform Height	Indoor	18.4 ft	5.6 m
	Outdoor	13 ft	4 m
Maximum Drive Height	Indoor	18.4 ft	5.6 m
	Outdoor	13ft	4 m
Stowed Height	Top Guardrail	83.3 in	2.12 m
	Guardrails Folded	79 in	2.0 m
	Platform Floor	39 in	1.0 m
Platform Extension Length		23.6 in	0.6 m
Machine Weight** (Unloaded)		2,820 lbs	1,280 kg
Maximum Lift Capacity		500 lbs	227 kg
Deck Extension Capacity		1 Person / 250 lbs (113 kg)	
Xtra Deck Capacity		1 Person / 250 lbs (113 kg)	
Maximum Occupants (Indoors)	Xtra Deck Deployed	1 Person	
	Xtra Deck Stowed	2 Person	
Maximum Occupants (Outdoors)	Xtra Deck Deployed	1 Person	
	Xtra Deck Stowed	1 Person	
Manual Force	Indoor	45 lbs	200 N
	Outdoor	45 lbs	200 N
Platform Length	Extended	78 in	2.0 m
	Retracted	54 in	1.4 m
Width (Overall)		32 in	0.81 m
Platform Dimensions (Length x Width)		53.9 x 27.6 in	1.37 x 0.7 m
Wheel Base		44.5 in	1.13 m
Turning Radius - Inside		17.7 in	0.45 m
Ground Clearance	Stowed	2.4 in	6.0 cm
	Elevated	0.6 in	1.5 cm
Drive Speed (Proportional)	Stowed	0-2.5 mph	0-4.0 km/h
	Raised/Extended	0-0.5 mph	0-8.0 km/h
Gradability		25% (14°)	
Maximum Side Slope - Stowed		5°	
Ground Pressure/Wheel		116 psi	8.2 kg/cm <sup>2</sup>
Maximum Wheel Load		990 lbs	450 kg
Occupied Floor Pressure		242 psf	1,177 kg/m <sup>2</sup>
Maximum Operating Wind Speed		28 mph	12.5 m/sec (45 km/h)
Tire Size		9 x 4 inch	230 x 100 mm
Lug Nut Torque		19 Ft-lbs / 25.5 N-m, Secured with cotter pin	
Hydraulic Pressure		2,320 psi	160 bar
Power System Voltage		24 Volt DC	
Battery Charger	Input	110-230 V AC, 50-60 Hz	
	Output	24 Volt DC	
Batteries		Two 12 Volt Deep Cycle 115Ah	
Chassis Inclination		1.5 Side / 3.0 Inline	
Airborne Noise Emissions		<70 dB	
Meets applicable requirements of ANSI A92.20-2020 & CSA B354.6-2019.			
*Working Height adds 6 feet (2 meters) to platform height.			
**Weight may increase with certain options.			

## Maintenance Lock

**DEATH OR SERIOUS INJURY HAZARD!**



**WARNING**

**NEVER PERFORM WORK OR INSPECTION ON THE MACHINE WITH THE PLATFORM ELEVATED WITHOUT FIRST BLOCKING THE SCISSOR ASSEMBLY WITH THE MAINTENANCE LOCK.**

1. Raise the platform approximately 8 feet (2.5 meters) from the ground.
2. Rotate the Maintenance Lock away from the machine and let it hang down.
3. Lower the platform until the Maintenance Lock rests securely on the link. Keep clear of the Maintenance Lock when lowering the platform.

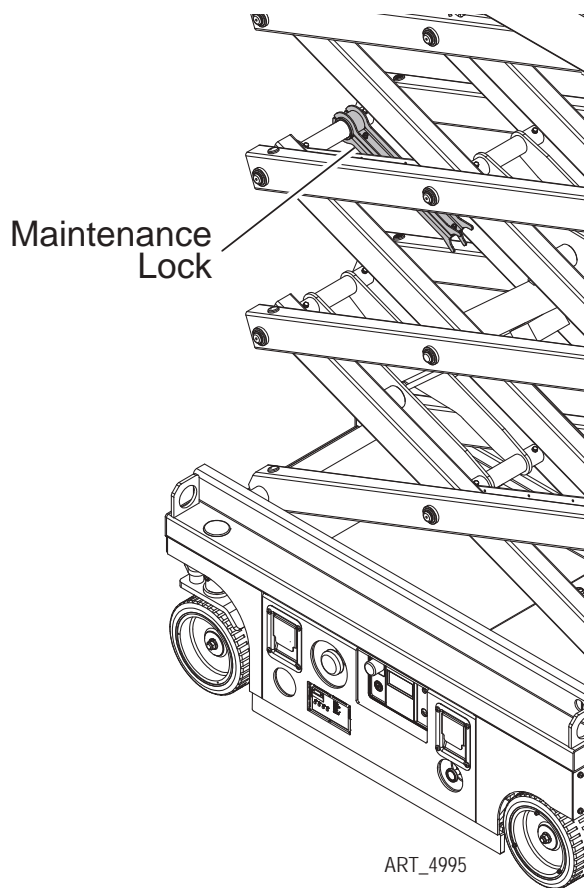

# Machine Systems

## Hydraulic System

---



**HYDRAULIC FLUID UNDER PRESSURE CAN PENETRATE AND BURN SKIN, DAMAGE EYES, AND MAY CAUSE SERIOUS INJURY, BLINDNESS, AND EVEN DEATH.**

**CORRECT LEAKS IMMEDIATELY.**

---



**Hydraulic fluid leaks under pressure may not always be visible. Check for pin hole leaks with a piece of cardboard, not your hand.**

---

## Electrical System

---



**Prevent damage to battery and/or electrical system;**

- **Always disconnect the negative battery cable first.**
  - **Always connect the positive battery cable first.**
- 

When the negative cable is installed, a spark will occur if contact is made between the positive side of the battery and a metal surface on the machine. This can cause damage to the electrical system, battery explosion, and personal injury.

## Total System

---

**FAILURE TO PERFORM PREVENTIVE MAINTENANCE AT RECOMMENDED INTERVALS MAY RESULT IN THE UNIT BEING OPERATED WITH A DEFECT THAT COULD RESULT IN INJURY OR DEATH OF THE OPERATOR.**



**IMMEDIATELY REPORT TO YOUR SUPERVISOR ANY DEFECT OR MALFUNCTION. ANY DEFECT SHALL BE REPAIRED PRIOR TO CONTINUED USE OF THE AERIAL WORK PLATFORM.**

**INSPECTION AND MAINTENANCE SHOULD BE PERFORMED BY QUALIFIED PERSONNEL FAMILIAR WITH THE EQUIPMENT.**

---

# Primary Machine Components

## Xtra Deck Up

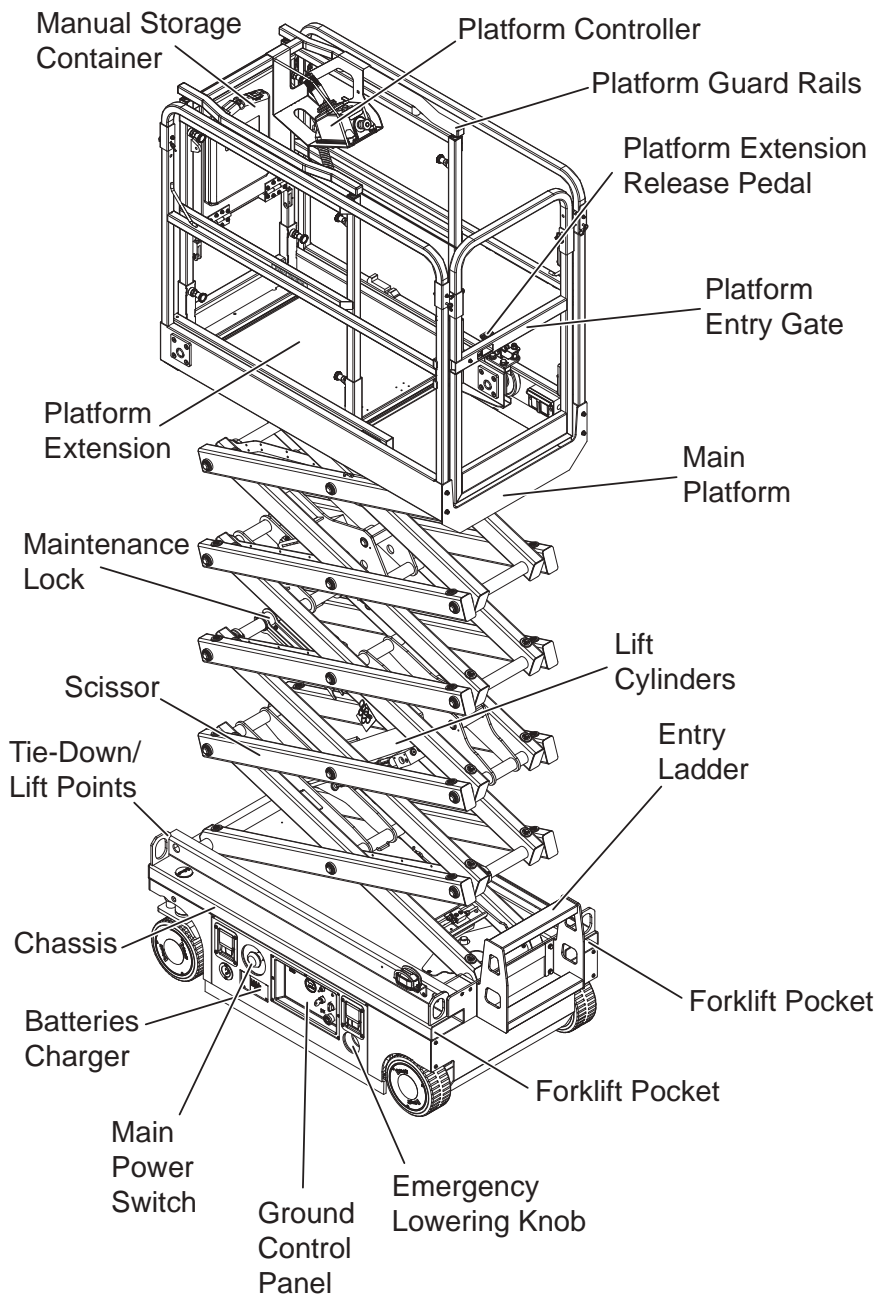

## Xtra Deck Down

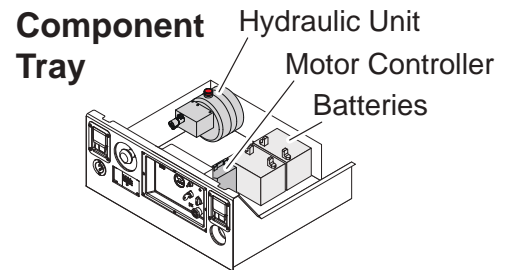
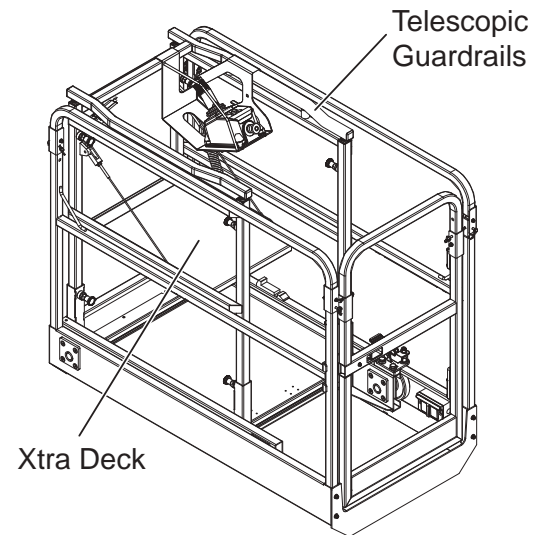

**mec**  
ILLUSTRATION No.  
ART\_5594

## Emergency Systems and Procedures



**IF THE CONTROL SYSTEM FAILS WHILE THE PLATFORM IS ELEVATED, HAVE AN EXPERIENCED OPERATOR USE THE EMERGENCY LOWERING PROCEDURE TO SAFELY LOWER THE PLATFORM.**

**DO NOT ATTEMPT TO CLIMB DOWN ELEVATING ASSEMBLY.**

### Emergency Stop

The machine is equipped with an EMERGENCY STOP switch at the base controls and the platform control box.

- Press the EMERGENCY STOP switch at any time to stop all machine functions.
- Pull switch to reset.
- Either switch will stop all machine functions.
- Both switches must be reset or machine will not operate.



ART\_3353

### Emergency Lowering



**IF THE CONTROL SYSTEM FAILS WHILE THE PLATFORM IS ELEVATED, USE THE EMERGENCY LOWERING PROCEDURE TO SAFELY LOWER THE PLATFORM.**

**DO NOT CLIMB DOWN THE ELEVATING ASSEMBLY OR EXIT THE PLATFORM.**

The Emergency Lowering System is used to lower the platform in case of power failure.

To lower the platform, pull the Emergency Lowering Knob, located near the Base Control panel.

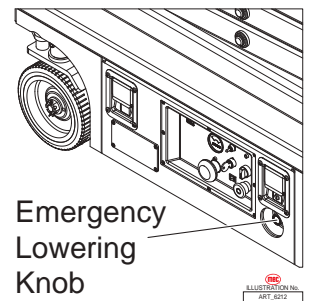

ILLUSTRATION No.  
ART\_6272

## Free-Wheel Configuration for Winching or Towing

### RUNAWAY HAZARD!



**AFTER RELEASING THE BRAKES THERE IS NOTHING TO STOP MACHINE TRAVEL. MACHINE WILL ROLL FREELY ON SLOPES.**

**ALWAYS CHOCK THE WHEELS BEFORE MANUALLY RELEASING THE BRAKES.**

The machine can be winched or towed short distances at speeds not to exceed 2.5mph (4km/h). Before towing or winching the machine, it is necessary to release the brakes. Reset the brakes after towing or winching.

### Disengage Brakes Before Towing Or Winching

1. Chock the wheels.
2. Turn the Key Switch to the Off position (pushed in).
3. Pull the Red Emergency Stop button out to the On position (pulled out) at both the ground and platform controls.
4. At the Ground Controls panel, push and hold the red rocker switch to the left & push down and hold the Platform Lift Switch.
5. An alarm will sound, signaling that the brakes have been released.

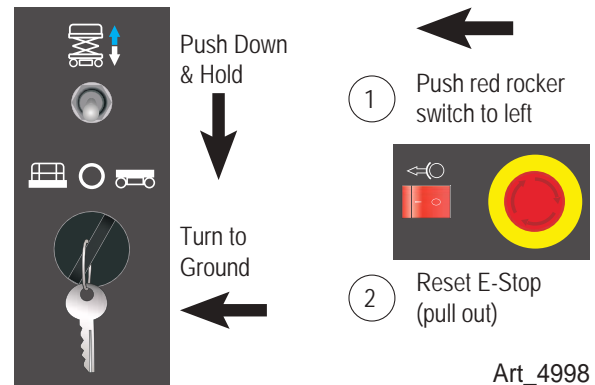

### Resetting Brakes

Push in the Emergency Stop button or turn the Key Switch to the Off position to reset the brakes.



**BE SURE THAT THE BRAKES ARE ENGAGED BEFORE REMOVING THE WHEEL CHOCKS.**



## Lift and Support the Machine



**DEATH OR SERIOUS PERSONAL INJURY MAY RESULT FROM THE USE OF SUBSTANDARD LIFTING DEVICES AND/OR JACK STANDS. ENSURE THAT ALL LIFTING DEVICES AND JACK STANDS ARE OF ADEQUATE CAPACITY AND IN GOOD WORKING CONDITION BEFORE USE.**

The following are needed to safely lift and support the machine;

- A jack with a lifting capacity of two (2) tons or more.
- Jack stands with a rating of two (2) tons or more.

### To Raise the Machine

1. Move machine to a firm level surface capable of supporting the weight of the machine.
2. Chock tires on one end of machine and raise the other end of machine.
3. Position a jack at the end of the machine to be lifted, under a solid lifting point in the center of the frame.
4. Raise the machine and place two (2) suitable jack stands under solid support points at the outer ends of the frame.
5. Lower the machine to rest on the jack stands and inspect for stability.

### To Lower the Machine

1. Raise machine slightly and remove jack stands.
2. Lower the machine and remove the jack.
3. Remove chocks.

## General Machine Maintenance

Instructions in this portion of the manual are to be used in conjunction with the Pre-Start, Frequent and Annual Inspection checklists found in this machine's Operator's Manual.

**IMPORTANT:** Scheduled maintenance inspection checklists are included in the Operator's Manual for use only by qualified service technicians. Only qualified service technicians may perform repairs to the machine. After repairs are completed, the operator must perform a Pre-Start Inspection before proceeding to the Functions Test.



**HYDRAULIC FLUID UNDER PRESSURE CAN PENETRATE AND BURN SKIN, DAMAGE EYES, AND MAY CAUSE SERIOUS INJURY, BLINDNESS, AND DEATH. REPAIR LEAKS IMMEDIATELY. FLUID LEAKS UNDER PRESSURE MAY NOT ALWAYS BE VISIBLE. CHECK FOR PIN HOLE LEAKS WITH A PIECE OF CARDBOARD, NOT YOUR HAND.**



**NEVER PERFORM WORK OR INSPECTION ON THE MACHINE WITH THE PLATFORM ELEVATED WITHOUT FIRST BLOCKING THE SCISSOR ASSEMBLY WITH THE MAINTENANCE LOCK (SEE THE INTRODUCTION PORTION OF THIS MANUAL).**

**PERFORM SCHEDULED MAINTENANCE AT RECOMMENDED INTERVALS. FAILURE TO PERFORM SCHEDULED MAINTENANCE AT RECOMMENDED INTERVALS MAY RESULT IN A DEFECTIVE OR MALFUNCTIONING MACHINE AND MAY RESULT IN INJURY OR DEATH OF THE OPERATOR. KEEP MAINTENANCE RECORDS CURRENT AND ACCURATE.**

**IMMEDIATELY REPORT ANY DAMAGE, DEFECT, UNAUTHORIZED MODIFICATION OR MALFUNCTION TO YOUR SUPERVISOR. ANY DEFECT MUST BE REPAIRED PRIOR TO CONTINUED USE. DO NOT USE A DAMAGED, MODIFIED OR MALFUNCTIONING MACHINE.**

**Never leave hydraulic components or hoses open. Plug all hoses and fitting immediately after disassembly to protect the system from outside contamination (including rain).**

**Never open a hydraulic system when there are contaminants in the air.**



**Always clean the surrounding area before opening hydraulic systems.**

**Use only recommended lubricants. Improper lubricants or incompatible lubricants may cause as much damage as no lubrication.**

**Watch for makeshift "fixes" which can jeopardize safety as well as lead to more costly repair.**



Inspection and maintenance should be performed by qualified personnel familiar with the equipment.

### 30-Day Service

Items on this checklist should be inspected before each work shift. Refer to the Operator's Manual.

The 30 day maintenance procedure is a **one-time** procedure to be performed after the first 30 days or 40 hours of usage.

Maintaining the tires and wheels in good condition is essential to safe operation and good performance. Tire and/or wheel failure could result in a machine tip-over. Component damage may also result if problems are not discovered and repaired in a timely fashion.

1. Check the tire surface and sidewalls for cuts, cracks, punctures and unusual wear.
2. Check each wheel for damage, bends and cracks.
3. Remove the wheel covers and check each center lock nut for proper torque and presence of cotter pin.

<b>Front</b>	
Castle Nut Torque, Dry	166.7 ft-lbs (226 Nm)
Castle Nut Torque, Lubricated	125.4 ft-lbs (170 Nm)

<b>Back</b>	
Locknut	100ft-lbs (135 Nm)

## Pre-Start Inspection Checklist

The operator must conduct a Pre-Start Inspection of the machine before each work shift.

DO NOT use a damaged or malfunctioning machine.

	Be sure that the operator's manual are complete, legible and in the storage container located in the platform.
	Be sure that all decals are legible and in place. See Decals section.
	Check for hydraulic oil leaks.
	Check for battery fluid leaks.

**Check the following components or areas for damage, improperly installed or missing parts and unauthorized modifications:**

	Electrical components, wiring and electrical cables
	Battery connections
	Hydraulic hoses, fittings, cylinders and manifolds
	Battery pack and connections
	Drive motors
	Slide blocks/wear pads
	Tires and wheels
	Ground strap
	Limit switches, alarm and beacon
	Nuts, bolts and other fasteners
	Platform entry gate
	Beacons and alarms
	Maintenance Lock
	Platform extension
	Scissor pins and retaining fasteners
	Platform control joystick
	Brake release components
	Pothole guards

**Check entire machine for:**

	Cracks in welds or structural components
	Dents or damage to machine
	Be sure that all structural and other critical components are present and all associated fasteners and pins are in place and properly tightened
	Be sure that guard rails are properly installed and secured, and that all pins and bolts are properly fastened.
	Be sure that the chassis trays are closed and latched and the batteries are properly connected.



**NEVER perform work or inspection on the machine with the platform elevated without first blocking the scissor assembly with the Maintenance Lock. See page 8 for instructions.**

## Frequent Inspection Checklist



**THIS CHECKLIST MUST BE USED AT 3-MONTH INTERVALS OR EVERY 150 HOURS OF MACHINE USE, WHICHEVER OCCURS FIRST. FAILURE TO DO SO COULD RESULT IN DEATH OR SERIOUS INJURY.**

Frequent Maintenance Inspections should be conducted by qualified service technicians only. Photocopy the Frequent Inspection Checklist page from the Operator's Manual to keep record of this inspection. Keep inspections records up to date. Record and report all discrepancies to your supervisor.

Perform all checks listed on Pre-Start Inspection, then proceed with the following checks.

### Hydraulic Fluid

Inspect the condition of hydraulic fluid in the reservoir. Oil should be a clear and amber in color.

### Batteries

Proper battery condition is essential to good machine performance and operational safety. Improper or damaged cables and connections can result in component damage and hazardous conditions.

**ELECTROCUTION / BURN HAZARD. CONTACT WITH ELECTRICALLY CHARGED CIRCUITS COULD RESULT IN DEATH OR SERIOUS INJURY.**



**REMOVE ALL RINGS, WATCHES AND OTHER JEWELRY.**

**BODILY INJURY HAZARD. BATTERIES CONTAIN ACID. AVOID SPILLING OR CONTACTING BATTERY ACID. NEUTRALIZE BATTERY ACID SPILLS WITH BAKING SODA AND WATER.**

1. Put on protective clothing and eye wear.
2. Slide out the component tray from the chassis.
3. Be sure that the battery cable connections are free of corrosion.

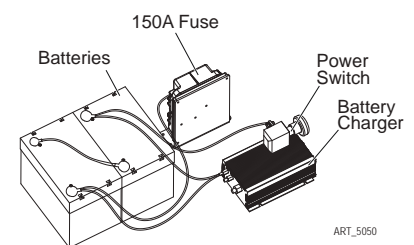

**Note:** Adding terminal protectors and a corrosion preventative sealant will help eliminate corrosion on the battery terminals and cables.

4. Be sure that the battery retainers and cable connections are tight.
5. Fully charge the batteries. Allow the batteries to rest 24 hours before performing this procedure to allow the battery cells to equalize.
6. Check each battery pack and verify that the batteries are wired correctly.
7. Inspect the battery charger plug and pigtail for damage or excessive insulation wear. Replace as required.
8. Connect the battery charger to a properly grounded 110-230V (50-60 Hz) single phase AC

power supply.

- **Result:** The charger should operate and begin charging the batteries.
- **Result:** If, simultaneously, the charger alarm sounds and the LEDs blink, correct the charger connections at the fuse and battery. The charger will then operate correctly and begin charging the batteries.

**Note:** For best results, use an extension cord of adequate size with a length no longer than 50 feet (15 meters).

**Note:** If you have any further questions regarding the battery charger operation, please contact the MEC Customer Service.

## Electrical Wiring

Maintaining electrical wiring in good condition is essential to safe operation and good machine performance. Failure to find and replace burnt, chafed, corroded or pinched wires could result in unsafe operating conditions and may cause component damage.



**ELECTROCUTION / BURN HAZARD. CONTACT WITH ELECTRICALLY CHARGED CIRCUITS COULD RESULT IN DEATH OR SERIOUS INJURY.**

**REMOVE ALL RINGS, WATCHES AND OTHER JEWELRY.**

1. Inspect the following areas for burnt, chafed, corroded and loose wires:
  - Ground Control Panel
  - Hydraulic Power Unit Module Tray
  - Platform Controls
2. Turn the key switch to ground control and pull the red Emergency Stop button out to the On position (pulled out) at both the ground and platform controls
3. Raise the platform approximately 8 feet (2.5 meters) from the ground.
4. Lift the safety arm, move it to the center of the scissor arm and rotate up to a vertical position.
5. Lower the platform onto the safety arm.



**CRUSHING HAZARD. KEEP HANDS CLEAR OF THE SAFETY ARM WHEN LOWERING THE PLATFORM.**

6. Inspect the center chassis area and scissor arms for burnt, chafed and pinched cables.
7. Inspect the following areas for burnt, chafed, corroded, pinched and loose wires:
  - Scissor Arms
  - ECU to Platform Controls
  - Power to Platform Wiring
8. Inspect for a liberal coating of dielectric grease in the following locations:
  - Between the ECU and platform controls
  - All wire harness connectors Level sensor
9. Raise the platform and return the safety arm to the stowed position.
10. Lower the platform to the stowed position and turn the machine off.

## Tires and Wheels

Maintaining the tires and wheels in good condition is essential to safe operation and good performance. Tire and/or wheel failure could result in a machine tip-over. Component damage may also result if problems are not discovered and repaired in a timely fashion.

- Check the tire surface and sidewalls for cuts, cracks, punctures and unusual wear.
- Check each wheel for damage, bends and cracks.
- Remove the wheel covers and check each center lock nut for proper torque and presence of cotter pin.

Front		Back	
Castle Nut Torque, Dry	166.7ft-lbs (226Nm)	Locknut	100ft-lbs (135Nm)
Castle Nut Torque, Lubricated	125.4ft-lbs (170Nm)		

## Emergency Stop

A properly functioning Emergency Stop system is essential for safe machine operation. An improperly operating red Emergency Stop button will fail to shut off power and stop all machine functions, resulting in a hazardous situation.

As a safety feature, selecting and operating from the ground controls will override all platform controls except the platform red Emergency Stop button.

1. Turn the key switch to ground control and pull the red Emergency Stop button out to the On position (pulled out) at both the ground and platform controls.
2. Push in the red Emergency Stop button at the ground controls to the Off position (pushed in).
  - **Result:** No machine functions should operate.
3. Turn the key switch to platform control and pull the red Emergency Stop button out to the On position (pulled out) at both the ground and platform controls.
4. Push in the red Emergency Stop button at the platform controls to the Off position (pushed in).
  - **Result:** No machine functions should operate.

**Note:** The red Emergency Stop button at the ground controls will stop all machine operation, even if the key switch is switched to platform control.

## Key Switch

Proper key switch action and response is essential to safe machine operation. The machine can be operated from the ground or platform controls and the activation of one or the other is accomplished with the key switch. Failure of the key switch to activate the appropriate control panel could cause a hazardous operating situation.

Perform this procedure from the ground using the platform controls. Do not stand in the platform.

1. Pull the red Emergency Stop button out to the On position (pulled out) at both the ground and platform controls.
2. Turn the key switch to platform control.
3. Check the platform up/down function from the ground controls.
  - **Result:** The machine functions should not operate.

4. Turn the key switch to ground control.
5. Check the machine functions from the platform controls.
  - **Result:** The machine functions should not operate.
6. Turn the key switch to the Off position (pushed in).
  - **Result:** No function should operate.

## Horn

The horn is activated at the platform controls and sounds at the ground as a warning to ground personnel. An improperly functioning horn will prevent the operator from alerting ground personnel of hazards or unsafe conditions.

1. Turn the key switch to platform control and pull the red Emergency Stop button out to the On position (pulled out) at both the ground and platform controls.
2. Push down the horn button at the platform controls.
  - **Result:** The horn should sound.

## Park Brake

Proper Park Brake performance is essential to safe machine operation. The machine uses two Park Brakes located in the rear of the chassis, mounted to the drive motors. Park Brakes are a Spring Applied Electrically Released (SAER) type designed to prevent unwanted machine travel anytime the drive function is idle.

Perform this procedure on a surface free of obstructions, with the platform extension deck fully retracted and the platform in the stowed position. Remove any items from the platform to prevent shifting loads.

Test the Park Brakes by driving the machine onto a 25 percent ramp and park the machine there. The Park Brakes should prevent the machine from rolling down the ramp. If the machine rolls more than 2 feet, replace both Park Brake units. Do not apply lubricants or any type of liquids to the brake units as doing so will reduce Park Brake effectiveness.

## Drive Speed, Lowered Platform

Proper drive functions are essential to safe machine operation. The drive function should respond quickly and smoothly to operator control. Drive performance should also be free of hesitation, jerking and unusual noise over the entire proportionally controlled speed range.

Perform this procedure with the machine on a firm, level surface that is free of obstructions.

1. Create start and finish lines by marking two lines on the ground 40 feet (12.2 meters) apart.
2. Turn the key switch to platform control and pull the red Emergency Stop button out to the On position (pulled out) at both the ground and platform controls.
3. Lower the platform to the stowed position.
4. Press the drive function select button.
5. Choose a point on the machine; i.e., contact patch of a tire, as a visual reference for use when crossing the start and finish lines.
6. Bring the machine to top drive speed before reaching the start line. Begin timing when your reference point on the machine crosses the start line.



7. Continue at full speed and note the time when your reference point on the machine passes over the finish line. The time should be 9-11 sec.

### **Drive Speed, Raised Platform**

Proper drive functions are essential to safe machine operation. The drive function should respond quickly and smoothly to operator control. Drive performance should also be free of hesitation, jerking and unusual noise over the entire proportionally controlled speed range.

Perform this procedure with the machine on a firm, level surface that is free of obstructions.

1. Create start and finish lines by marking two lines on the ground 40 feet (12.2 meters) apart.
2. Turn the key switch to platform control and pull the red Emergency Stop button out to the On position (pulled out) at both the ground and platform controls.
3. Press the lift function select button.
4. Press and hold the function enable switch on the joystick.
5. Raise the platform approximately 4 feet (1.2 meters) from the ground.
6. Press the drive function select button.
7. Choose a point on the machine; i.e., contact patch of a tire, as a visual reference for use when crossing the start and finish lines.
8. Bring the machine to top drive speed before reaching the start line. Begin timing when your reference point on the machine crosses the start line.
9. Continue at full speed and note the time when your reference point on the machine passes over the finish line. The time should be 35-40 sec.

### **Drive Speed, Slow**

Proper drive functions are essential to safe machine operation. The drive function should respond quickly and smoothly to operator control. Drive performance should also be free of hesitation, jerking and unusual noise over the entire proportionally controlled speed range.

Perform this procedure with the machine on a firm, level surface that is free of obstructions.

1. Create start and finish lines by marking two lines on the ground 40 feet (12.2 meters) apart.
2. Turn the key switch to platform control and pull the red Emergency Stop button out to the On position (pulled out) at both the ground and platform controls.
3. Lower the platform to the stowed position.
4. Press the slow speed select button.
5. Choose a point on the machine; i.e., contact patch of a tire, as a visual reference for use when crossing the start and finish lines.
6. Bring the machine to top drive speed before reaching the start line. Begin timing when your reference point on the machine crosses the start line.
7. Continue at full speed and note the time when your reference point on the machine passes over the finish line. The time should be 18-22 sec.

### **Hydraulic Oil Analysis**

Replacement or testing of the hydraulic oil is essential for good machine performance and service life. Dirty oil may cause the machine to perform poorly and continued use may cause component damage. Extremely dirty conditions may require oil changes to be performed more often.

Before replacing the hydraulic oil, the oil may be tested by an oil distributor for specific levels of contamination to verify that changing the oil is necessary.

Hydraulic oil should be tested yearly and replaced if it fails. If the hydraulic oil is not replaced at the Annual Inspection, test the oil quarterly. Replace the oil when it fails the test.

### Tank Venting System

A free-breathing hydraulic tank cap is essential for good machine performance and service life. A dirty or clogged cap may cause the machine to perform poorly. Extremely dirty conditions may require that the cap be inspected more often.

1. Remove the breather cap from the hydraulic tank.
2. Check for proper venting.
  - **Result:** Air passes through the breather cap.
  - **Result:** If air does not pass through the cap, clean or replace the cap. Proceed to step 3.

**Note:** When checking for positive tank cap venting, air should pass freely through the cap.

3. Using a mild solvent, carefully wash the cap venting system. Dry using low pressure compressed air. Repeat step 2.
4. Install the breather cap onto the hydraulic tank.

# Annual Inspection Checklist



**THIS CHECKLIST MUST BE USED AT 12-MONTH INTERVALS OR EVERY 600 HOURS OF MACHINE USE, WHICHEVER OCCURS FIRST. FAILURE TO DO SO COULD RESULT IN DEATH OR SERIOUS INJURY.**

Annual Maintenance Inspections should be conducted by qualified service technicians only. Photocopy the Annual Inspection Checklist page from the Operator's Manual to keep record of this inspection. Keep inspections records up to date. Record and report all discrepancies to your supervisor.

Perform all checks listed on Pre-Start Inspection and the Frequent Inspection, then check all items listed on the Annual Inspection Report. See specific instructions below.

## Scissor Slide Blocks

Maintaining the condition of the scissor arm slide blocks is essential to safe machine operation. Continued use of worn out wear pads may result in component damage and unsafe operating conditions.

Perform this procedure with the platform in the stowed position.

1. Measure the distance between the number one inner arm cross tube and the chassis deck at the ground controls side of the non-steer end of the machine.
  - **Result:** The measurement is 1.18 inches (30 millimeters) or more. Proceed to step 2.
  - **Result:** The measurement is less than 1.18 inches (30 millimeters). Replace both wear pads.
2. Measure the distance between the number one inner arm cross tube and the chassis deck at the battery pack side of the non-steer end of the machine.
  - **Result:** The measurement is 1.18 inches (30 millimeters) or more. Proceed to step 3.
  - **Result:** The measurement is less than 1.18 inches (30 millimeters). Replace both wear pads.
3. Apply a thin layer of dry film lubricant to the area of the chassis where the scissor arm wear pads make contact.

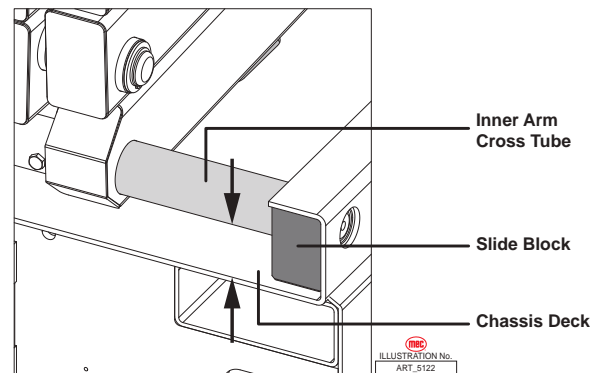

## Hydraulic Tank Breather Cap

The hydraulic tank is a vented-type tank. The breather cap has an internal air filter that can become clogged or, over time, can deteriorate.

If the breather cap is faulty or improperly installed, impurities can enter the hydraulic system which may cause component damage. Extremely dirty conditions may require that the cap be inspected more often.

1. Remove and discard the hydraulic tank breather cap.
2. Install a new cap onto the tank.

## Hydraulic Oil Inspection

Replacement or testing of the hydraulic oil is essential for good machine performance and service life. Dirty oil may cause the machine to perform poorly and continued use may cause component damage. Extremely dirty conditions may require oil changes to be performed more often.

Before replacing the hydraulic oil, the oil may be tested by an oil distributor for specific levels of contamination to verify that changing the oil is necessary.

Hydraulic oil should be tested yearly and replaced if it fails. If the hydraulic oil is not replaced at the Annual Inspection, test the oil quarterly. Replace the oil when it fails the test.

**Note:** Perform this procedure with the platform in the stowed position.

1. Slide out the Component Tray.
2. Disconnect the battery pack from the machine.



**ELECTROCUTION / BURN HAZARD. CONTACT WITH ELECTRICALLY CHARGED CIRCUITS COULD RESULT IN DEATH OR SERIOUS INJURY.**

**REMOVE ALL RINGS, WATCHES AND OTHER JEWELRY.**

3. Tag and disconnect the hydraulic pump outlet line and remove the line from the pump. Cap the fitting on the pump.
4. Loosen the bolts and remove the hydraulic power pack from the tray.
5. Open the oil plug of tank. Drain all of the oil into a suitable container.
6. Loosen and remove the bolts and separate the tank from the pump body.

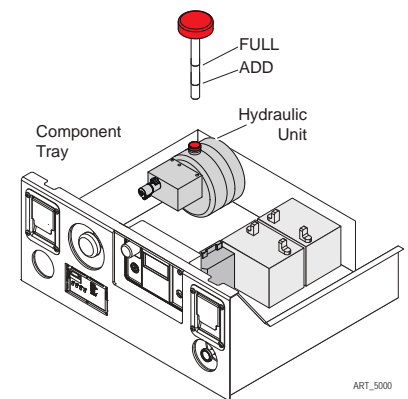

**BODILY INJURY HAZARD. SPRAYING HYDRAULIC OIL CAN PENETRATE AND BURN SKIN. LOOSEN HYDRAULIC CONNECTIONS VERY SLOWLY TO ALLOW THE OIL PRESSURE TO DISSIPATE GRADUALLY. DO NOT ALLOW OIL TO SQUIRT OR SPRAY.**

7. Clean up any oil that may have spilled. Properly discard the used oil.
8. Clean the inside of the hydraulic tank using a mild solvent. Allow the tank to dry completely.
9. Install the hydraulic tank and install and tighten the hydraulic tank retaining fasteners. Torque to specification.
  - Hydraulic Tank Retaining Fasteners, Dry: 35in-lbs (4Nm)
  - Hydraulic Tank Drain Plug, Lubricated: 26in-lbs (3Nm)
10. Install the hydraulic power pack into the component tray. Install the fitting and hydraulic hoses

onto the hydraulic power pack and torque.

11. Fill the tank with hydraulic oil to the middle of the dipstick. Do not overfill.

12. Activate the pump to fill the hydraulic system with oil and bleed the system of air.



**COMPONENT DAMAGE HAZARD. THE PUMP CAN BE DAMAGED IF OPERATED WITHOUT OIL. BE CAREFUL NOT TO EMPTY THE HYDRAULIC TANK WHILE IN THE PROCESS OF FILLING THE HYDRAULIC SYSTEM. DO NOT ALLOW THE PUMP TO CAVITATE.**

---

# Maintenance Inspection Report

## SE & MICRO Series Scissors

Fleet Equipment Number \_\_\_\_\_ Date \_\_\_\_\_  
 Inspector Name \_\_\_\_\_ Inspector Co. \_\_\_\_\_  
 Model Number \_\_\_\_\_ Address \_\_\_\_\_  
 Serial Number \_\_\_\_\_  
 Hour Meter \_\_\_\_\_ Signature \_\_\_\_\_  
 Machine Owner & address \_\_\_\_\_

**Maintain all service records in accordance with ANSI A92.24-2019**

\* If an inspection receives an "N", remove from service. Once repaired, place an "R" in the box.  
 \* Refer to the proper service manual for specific information, settings and torque specifications.

**Key** Y = Yes, Acceptable N = No, Remove from Service R = Repaired 0 = Not Applicable

**QUARTERLY** - Inspect only those marked "Q"  **ANNUAL** - Inspect all items

	Q/A	Y/N/O	R
<b>DECALS:</b>			
Legible - undamaged/readable	Q		
Capacity decal correct for model	Q		
<b>RAILS:</b>			
Not damaged, all in place	Q		
All rail fasteners secure	Q		
Entry gate secure, closes properly	Q		
Manual box in good condition	Q		
Operators Manual in manual box	Q		
<b>PLATFORM EXTENSION:</b>			
Rolls in and out freely	Q		
Lock holds deck in place	Q		
Release pedal moves freely (lube)	Q		
<b>ELEVATING ASSEMBLY:</b>			
Scissor Slide Blocks, lubed	Q		
Maintenance Stand, good Cond	Q		
Beam structures: Straight, no cracks	A		
Welds: secure, no cracks	A		
Retaining Rings	A		
Cylinder Pins, secure	A		
<b>ELECTRICAL:</b>			
GFCI operates correctly	Q		
Wire harnesses good cond, secure	A		
Comm cable no damage, secure	A		
<b>BASE:</b>			
Fasteners tight	Q		
Cover panels secure	Q		
Welds	A		

	Q/A	Y/N/O	R
<b>WHEELS:</b>			
Tire damage	Q		
Lug nuts (Wheel mounting) torqued correctly	Q		
King Pins lubed	A		
<b>COMPONENT AREA:</b>			
Hydraulic - no leaks	Q		
Hydraulic tank, correct level	Q		
Hoses not damaged - Fittings tight	Q		
Valve manifold secure, no leaks	Q		
Power unit secure, no leaks	Q		
Batteries properly filled and cables clean	Q		
Emergency stop, cuts power/operation	Q		
Battery switch cuts battery feed	Q		
Plastic cover secure (door end 2632-4555 only)	A		
Hydraulic tank, oil clean	A		
Replace Hydraulic Filter (if equipped)	A		
Clean or replace tank breather filter	A		
<b>OPERATIONAL INSPECTION:</b>			
All functions, operate smooth and quiet	Q		
All functions, speeds correct.	Q		
Upper control box, operates correctly	Q		
Emergency Down, operates correctly	Q		
Limit switches slows drive when elevated	Q		
Pothole switch test	Q		
Steering pressure relief, set correctly	Q		
Lift pressure relief, set correctly	Q		
**Check Platform Overload Sensing operation	Q		

\*\*For machine equipped with Platform Overload Protection system only



# Control Component Locations

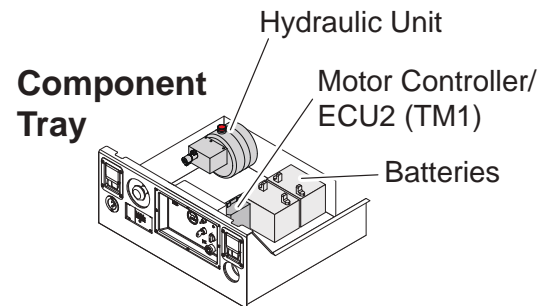
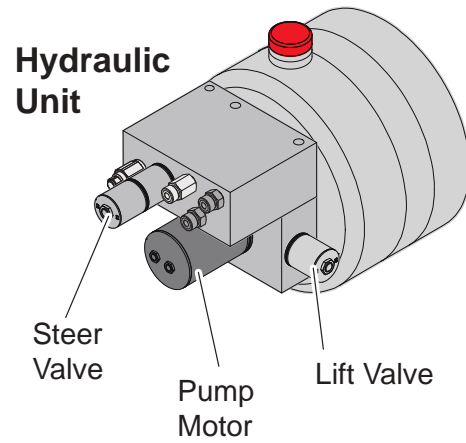
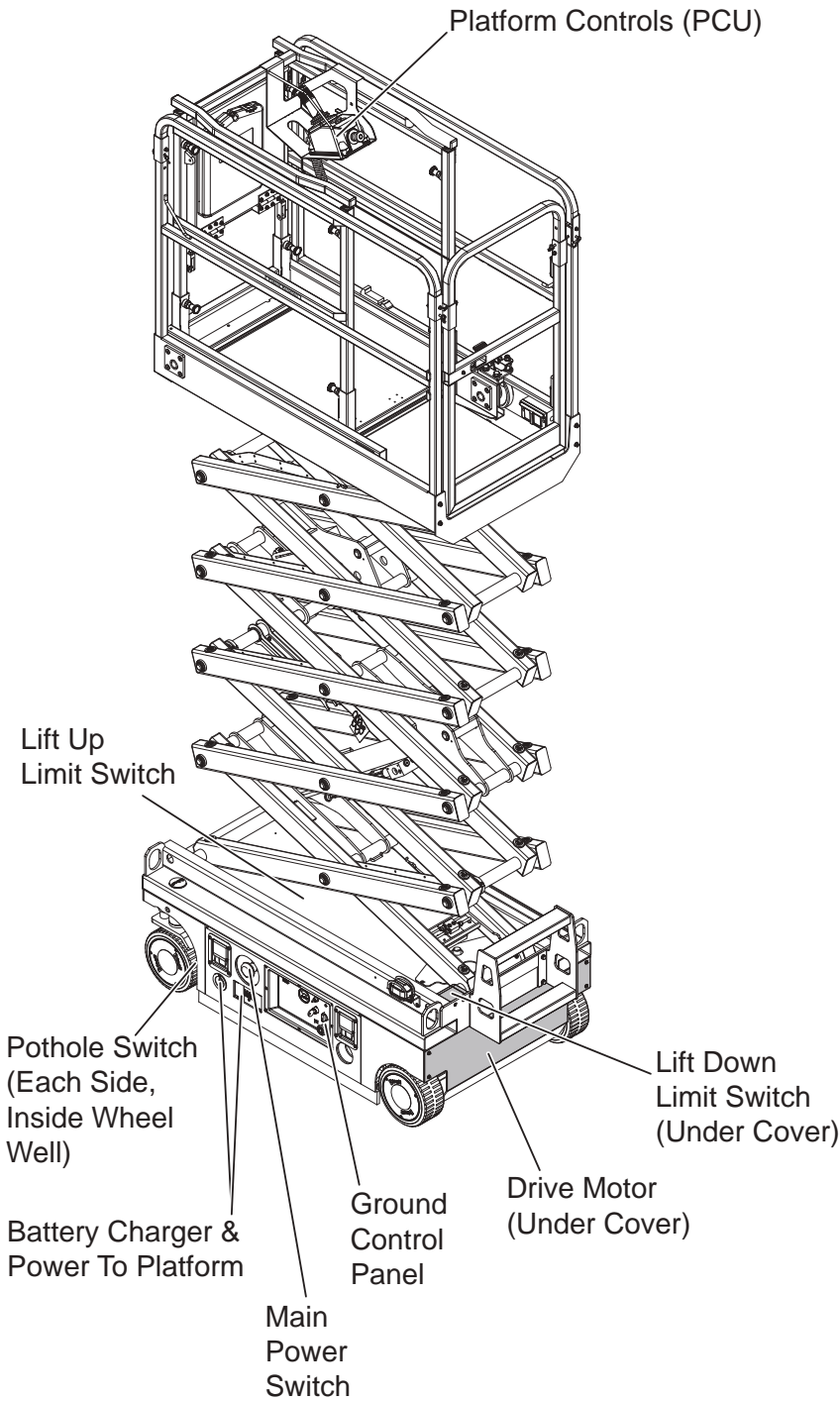
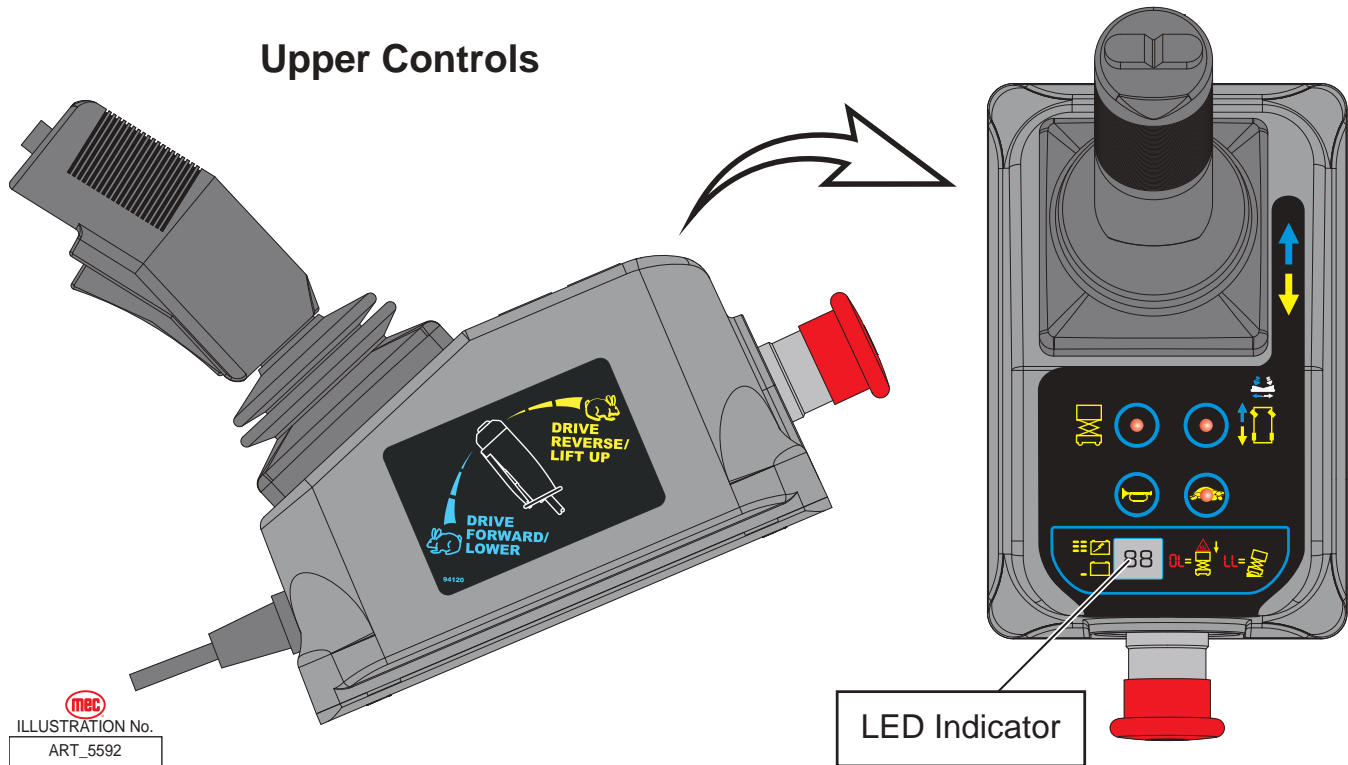

  
 ILLUSTRATION No.  
 ART\_5593

# Fault Codes

Fault Codes, when present, appear on the LED Indicator at the Upper Controls station and on the LED Screen at the Lower Controls station.

## Upper Controls



## Micro19-XD Lower Controls

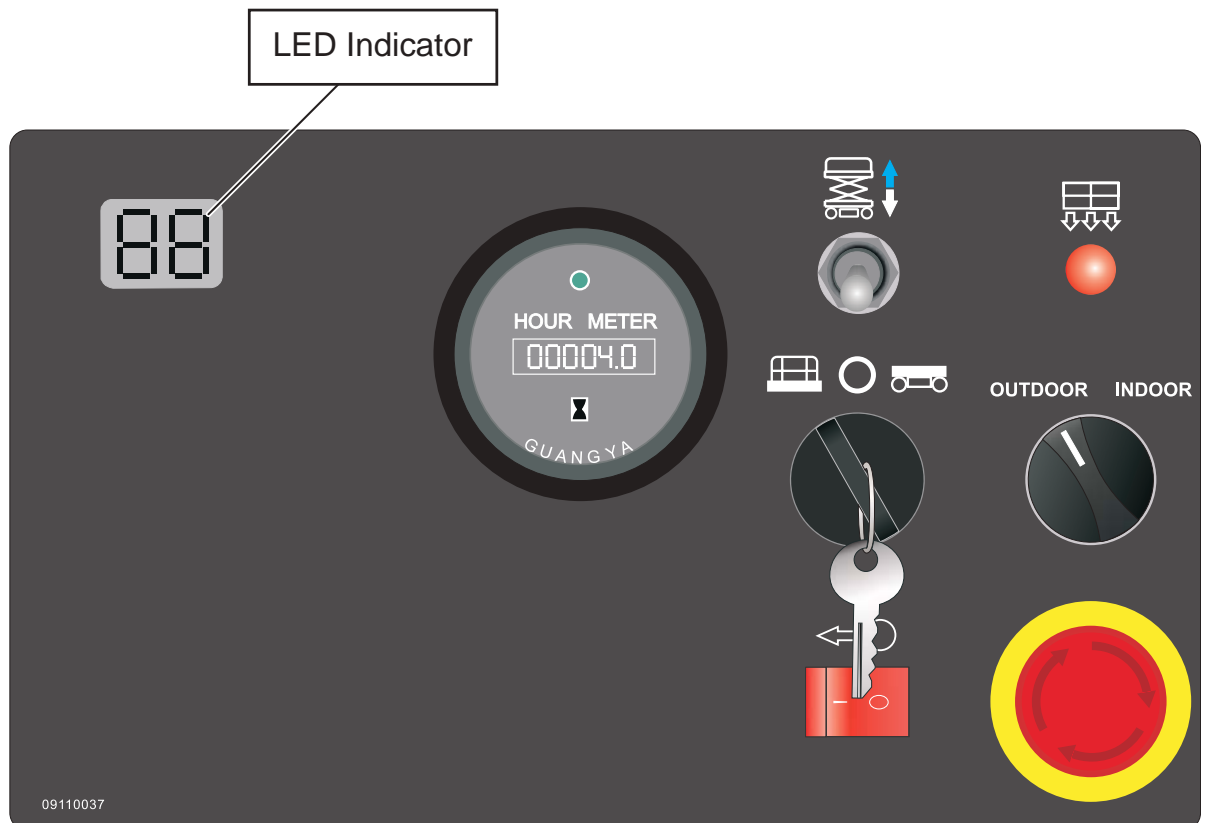



## Error Indicator Readout

If the LED diagnostic readout displays an error code, such as LL, push in and turn the red Emergency Stop button to reset the system.



Art\_5533

Fault	Description	Models	Solutions
01/10	System Initialization Fault	All Models	Check the ECU.
02/20	System Communication Fault	All Models	Check the platform control, wiring on platform connector, ECU, battery, and relay on ground control.
03	Invalid Option Setting	All Models	Reset the option code. See Service manual for instructions.
12	Chassis Up or Down Switch ON at power-up Fault	All Models	Check the wiring on toggle switch, and the toggle switch.
18	Pothole Guard Fault	All Models	Check the pothole board and switches. If stowed, check limit switch.
31	Pressure Sensor Fault	Micro 19	Check option code. See Service manual for instructions.
32	Angle Sensor Fault	All Models > 2020 With Overload	Check wiring to angle sensor for normal voltage range < 2020, 1.9-3.8V, then check the option code.
42	Left turn switch ON at power-up	All Models	Check the left steer button, and the platform controller.
43	Right Turn Switch ON at power-up	All Models	Check the right steer button, and the platform controller.
46	Joystick Enable Switch ON at power-up	All Models	Wait several seconds when turning on the lift, then check the joystick dead-man switch.
47	Joystick not in neutral at power-up	All Models	Check the joystick, and the platform controller.
52	Drive Forward Coil Fault	All Models	Check the option code. See Service manual for instructions.
53	Drive Reverse Coil Fault	All Models	Check the option code. See Service manual for instructions.
54	Lift Up Coil Fault	All Models	Check the lift solenoid and wiring.
55	Lift Down Coil fault	All Models	Check the down solenoid and wiring, and the scissor harness for crushed or pinched wires.
56	Right Turn Coil Fault	All Models	Check the right steering solenoid and wiring.
57	Left Turn Coil Fault	All Models	Check the left steering solenoid and wiring.
58	General Brake Coil Fault - Brakes about 46 ohms	All Models	Check the brake module and wiring, brakes and wiring, and the battery voltage.
60	Motor Controller Fault	All Models	Replace the motor controller.
61	Motor Controller Sensor Fault	All Models	Check the drive motor and wiring, and the drive motor controller and wiring.
62	Motor Controller Hardware Failsafe Fault	All Models	Cycle power, then replace the Motor Controller.
63	Motor Controller Output Fault	All Models	Check the drive motor and wiring for shorts, and the drive motor controller and wiring.
64	Motor Controller SRO Fault	All Models	Replace motor controller

Fault	Description	Models	Solutions
65	Motor Controller Throttle Fault	All Models	Replace motor controller
66	Motor Controller Emergency Reverse Fault	All Models	Replace motor controller
67	Motor Controller HPD Fault	All Models	Replace motor controller, check contactor, replace ECU.
68	Low Voltage Fault	All Models	Check battery voltage and charge batteries if necessary, check battery connections, connection from ECU to PCU, then the voltage to the ECU and PCU.
69	High Neutral Current Fault	All Models	Motor seized - This message comes just before other faults but should be ignored in those cases.
70	Steer Input Out of Range	All Models	Check for loose wires on motor controller, replace motor controller.
71	Motor Controller Main Contactor Fault	All Models	Check wiring to contactor, white and black wire could be off, check drive motor and wiring, and motor controller and wiring. Replace contractor.
72	Motor Controller Over Voltage Fault	All Models	Check battery voltage with battery charger off, cycle power to machine, replace motor controller.
73	Motor Controller Thermal Cutback Fault	All Models	Drive/Lift Motor may be overheating so let motor cool down, cycle power to reset Motor controller, replace motor controller.
74	Motor Controller Motor Fault	All Models	Check connections at motors "motor open", cycle power to the lift, and replace motor controller.
75	Motor Controller Pump Motor Fault	All Models	Check connections to the Pump Motor, cycle power to the lift, and replace motor controller.
76	Motor Controller Left Drive Motor Fault	All Models	Check connections to the motors, cycle power to the lift, and replace motor controller.
77	Motor Controller Right Drive Motor Fault	All Models	Check connections to the motors, cycle power to the lift, and replace motor controller.
78	Pump Motor Short Fault: 0.8-1.4 ohms	All Models	Check connections to the pump motor, cycle power to the lift, and replace motor controller.
79	Left Drive Motor Short Fault	1930SE Only	Check the left drive motor and wiring, and the ZAPI drive controller and wiring.
	(Should be 0.5-2.0 ohms)	Micro 19	Swap wires on drive motors: if code changes it's in wiring or motor and if code doesn't change it's in motor controller.
80	Over 80% Load Warning	All Models	Platform is getting close to limit of weight. > 2020 with overload
81	Right Drive Motor Short	1930SE/Micro	Check the right drive motor and wiring, and motor controller and wiring.
82	Right Brake Coil - Brakes about 46 ohms	1930SE/Micro	Check battery voltage, contactor, wiring to brakes, wiring to drive motors, motor controller and wiring.
		All Models	Check battery voltage, right motor brake and wiring, brake module and wiring, and contactor.
83	Left Brake Coil - Brakes about 46 ohms	1930SE/Micro	Check battery voltage, contactor, wiring on brakes, wiring to drive motors, motor controller and wiring.
		All Models	Check battery voltage, left motor brake and wiring, brake module and wiring, and contactor.

<b>Fault</b>	<b>Description</b>	<b>Models</b>	<b>Solutions</b>
85	Brake Release Switch Closed	1930SE/Micro	Turn brake release switch off. Replace brake release switch.
86	Raised Brake Release Fault	1930SE Only	Brake release switch engaged.
87	Brake Release Switch Fault	1930SE Only	Brake release switch open.
89	Drive Motor Field Open	All Models	Check wiring on motors and motor controller.
91	Left Drive Motor Short	All Models	Check wiring to motor and motor controller.
92	Right Drive Motor Short	All Models	Check wiring to motor and motor controller.
99	Over 99% Load Warning	All Models	Platform has reached its weight capacity.
OL	Platform Overloaded	All Models	Remove the excess load immediately. > 2020 with overload.
LL	Machine Tilted Beyond Safe Limits Fault	All Models	Check to see if machine is tilted, then check wiring to tilt sensor and the tilt sensor.
CH	NOT A FAULT CODE	All Models	Indicates that key switch is in base controls.

## Calibration Instructions

The Platform Overload Sensing System may require calibration in the event of a malfunction or after replacing an Overload System component. Proper and correct calibration of the Overload system is critical for normal and trouble-free machine operation. Please read and understand the instructions before beginning the calibration process.

### Calibrate Tilt Sensor

Tilt Sensor calibration is necessary only when the level indication is not correct. It is not necessary to calibrate the Tilt Sensor during Height and Overload Calibrations unless the level indication is not correct. The Tilt Sensor is located in the rear of the chassis. It will be necessary to remove the Drive Motor Cover Plate to gain access to the Tilt Sensor. The diagram below shows the Tilt Sensor removed from the machine for clarity.

1. Park the machine on flat level surface.

**Note:** Calibrating the level sensor requires that the machine be perfectly level on both the X and Y axis. An inclinometer should be used when ensuring machine level. Machine power must be on.

2. Using the diagram below, locate the “SET ZERO” button often located on the side of the sensor but may be on the top of the sensor. Press and hold the “SET ZERO” button until the LEDs alternate between red and green flashes. Release the button.
3. Immediately press the “SET ZERO” button three times. The LEDs will turn off then only the green LED will illuminate. Calibration is complete.



### Calibrate Height

**Note:** The platform must lift to full height to properly calibrate height. If low overhead obstructions prevent full elevation. Move the machine to a location that will not limit elevation. If machine cannot be moved, perform the full Height calibration at the maximum possible height. The Upper Point Calibration can be redone once the machine can be moved. It is a good idea to alert others to the need to re-calibrate if it cannot be calibrated correctly.

1. Make sure the platform is lowered to its fully stowed position.
2. Remove the upper control box from the guard rail and unplug it from the guard rail connection. Plug the upper control box into the connector located inside the lower control drawer.
3. Turn the Key Switch to the lower control position and turn all switches on.
4. Push the platform Emergency Stop (E-stop) Switch in.
5. Press and hold the Drive and Turtle buttons while pulling out the platform E-stop. Continue holding the buttons until “H9” (or “Hg”) appears in the upper control box display. Release the buttons. The system is now in Height Calibration mode.
6. Set the lower point calibration by simultaneously pressing and holding the Joystick Enable Trigger and the Right Steer button (the horn will sound for a couple seconds). When the horn turns off, the Lower Point Calibration will be set. Release the switches.

7. Set the Upper Point calibration by first elevating the platform. Use the lift switch in the lower panel to lift the platform to its highest position, the platform must be completely elevated (see NOTE above).
8. Simultaneously press and hold the Joystick Enable Trigger and the Left Steer button (the horn will sound for a couple seconds). When the horn turns off, the Upper Point Calibration will be set. Release the switches.
9. Set the Outdoor point calibration by first lowering the platform 5 feet only (from full elevation) using the lift switch on the lower panel. Simultaneously press and hold the Joystick Enable Trigger and the Lift button on the touch pad (the horn will sound for a couple seconds). When the horn turns off, the Outdoor Height Limit Calibration will be set. Release the switches.
10. Set the safe down point calibration by first lowering the platform about halfway (from full elevation) using the lift switch on the lower panel. Simultaneously press and hold the Joystick Enable Trigger and the Horn button on the touch pad (the horn will sound for a couple seconds). When the horn turns off, the Outdoor Height Limit calibration will be set. Release the switches.
11. Press the E-stop Switch in to turn the system off. This will finalize the calibration.
12. Pull the E-stop switch out to turn the machine back on, lower the platform and move the upper control cord back to the guard rail connection. Reconnect the lower plug and test all functions.

### Calibrate Overload System

**Note:** The platform **will lift automatically** once the calibration has been initiated. Be sure that there are **no overhead obstructions** when choosing a location on which to calibrate the overload system.

**Note:** If a safety concern arises anytime during the automated lift/lower sequence, press the Emergency Stop switch immediately. The procedure can be restarted once it is safe to do so.

### Empty Platform Sequence

1. Park the machine on flat level surface. Machine power must be on with the key switch in the Upper control position. Ensure that the platform is completely empty and there are no 'extra' items attached to the platform or guard rails that may add weight beyond that of an empty platform.
2. Using the lower Lift Switch (located on the lower control panel) perform the following sequence of up and down movement of the toggle switch.
  - 1) Down 5 times
  - 2) Up 1 time
  - 3) Down 5 times
  - 4) Up 1 time
  - 5) Down 1 time
  - 6) Up 1 time
  - 7) Down 3 times
3. The Platform will run through a series of lift and lower cycles. The process will be complete when the platform returns to the fully lowered and the horn stops sounding. Cycle Emergency Stop power and continue to the Loaded calibration steps.

### Loaded Platform Sequence

1. Park the machine on flat level surface. Machine power must be on with the key in the Platform position. Ensure that the platform is completely empty and there are no 'extra' items attached to

- the platform or guard rails that may add weight to the platform beyond that of an empty platform.
2. Locate the decal showing the Maximum Platform Capacity and record that weight number. Place recorded weight in the center of the platform.
  3. Using the lower Lift Switch (located on the lower control panel) perform the following sequence of up and down movement of the toggle switch.
    - 1) Down 5 times
    - 2) Up 1 time
    - 3) Down 5 times
    - 4) Up 1 time
    - 5) Down 5 time
  4. The platform will run through a series of lift and lower cycles. The process will be complete when the platform returns to the fully lowered and the horn stops sounding. Once the Empty and the Loaded sequences are complete, the Platform Overload Calibration is complete. Remove weight from platform and test all machine operations in accordance with the Pre-Inspection Check List located in the machine's operator's manual.

### Platform Overload Test Procedure

1. Park the machine on firm, level surface and remove all contents from platform.
2. Consult the Platform Capacity data plate for the Maximum Platform Weight Capacity information.
3. Load (approximately) 90% of that weight in the platform.
4. Lift the platform using the lower control lift switch.
  - The platform should raise and the display should read "90" indicating 90% load.
5. Add 50lbs (22.7kg) to the platform in addition to the weight added in step 3 then lift the platform.
  - The platform should lift 5-7 feet (1.5-2.1 meters) then stop lifting automatically. The alarms should sound and the display should read "OL". Use Emergency Lowering cable to lower the platform.
6. **Results:**
  - The platform stops lifting with less than the maximum rated platform capacity in the platform  
**OR**
  - The platform continues to lift with excessive weight in the platform.
    - Test Failed – recalibrate the overload system (refer to Overload Calibration in this section).
  - The Platform Overload Sensing System operates as described – Passed Test - Complete.

# Electrical Schematic

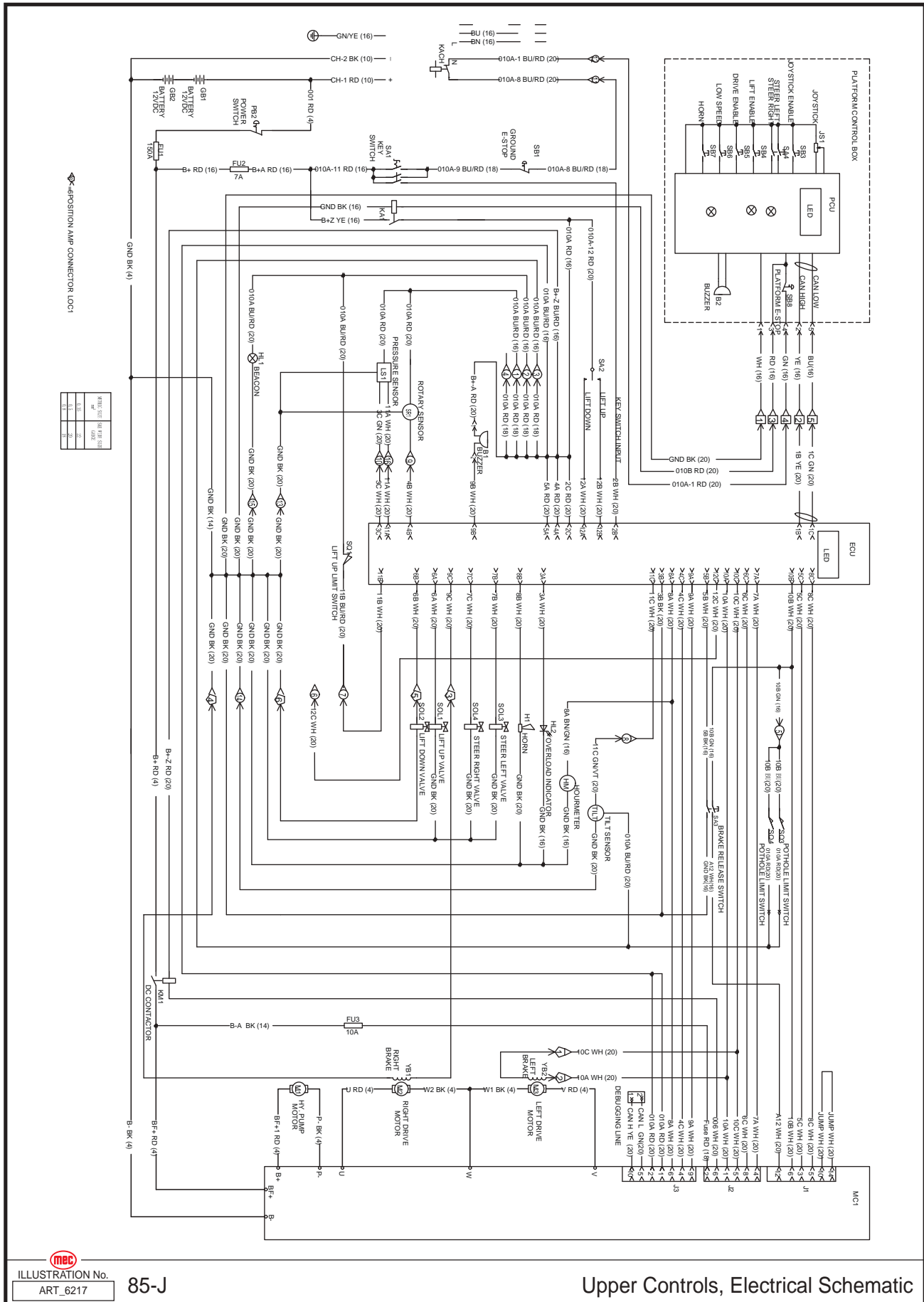

POSITION AMP CONNECTOR LOC1

RED (20)	RED (20)
OR (20)	OR (20)
BLK (20)	BLK (20)
WH (20)	WH (20)
RD (20)	RD (20)
YE (20)	YE (20)
GN (20)	GN (20)
BR (20)	BR (20)

ILLUSTRATION No. ART\_6217

85-J

Upper Controls, Electrical Schematic



# Hydraulic Schematic

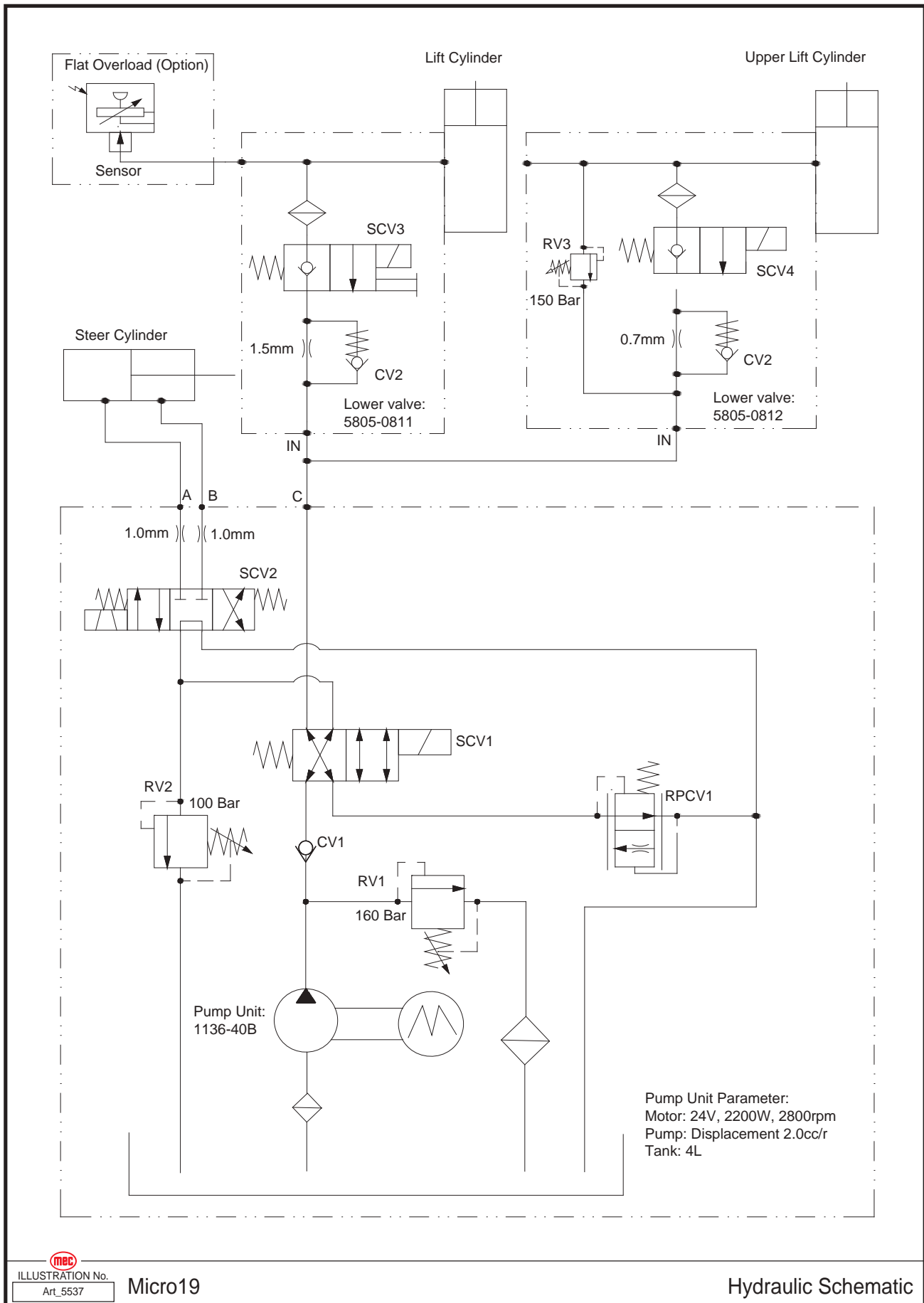

ILLUSTRATION No. **Micro19**  
 Art\_5537

Hydraulic Schematic



# Hydraulic Cap

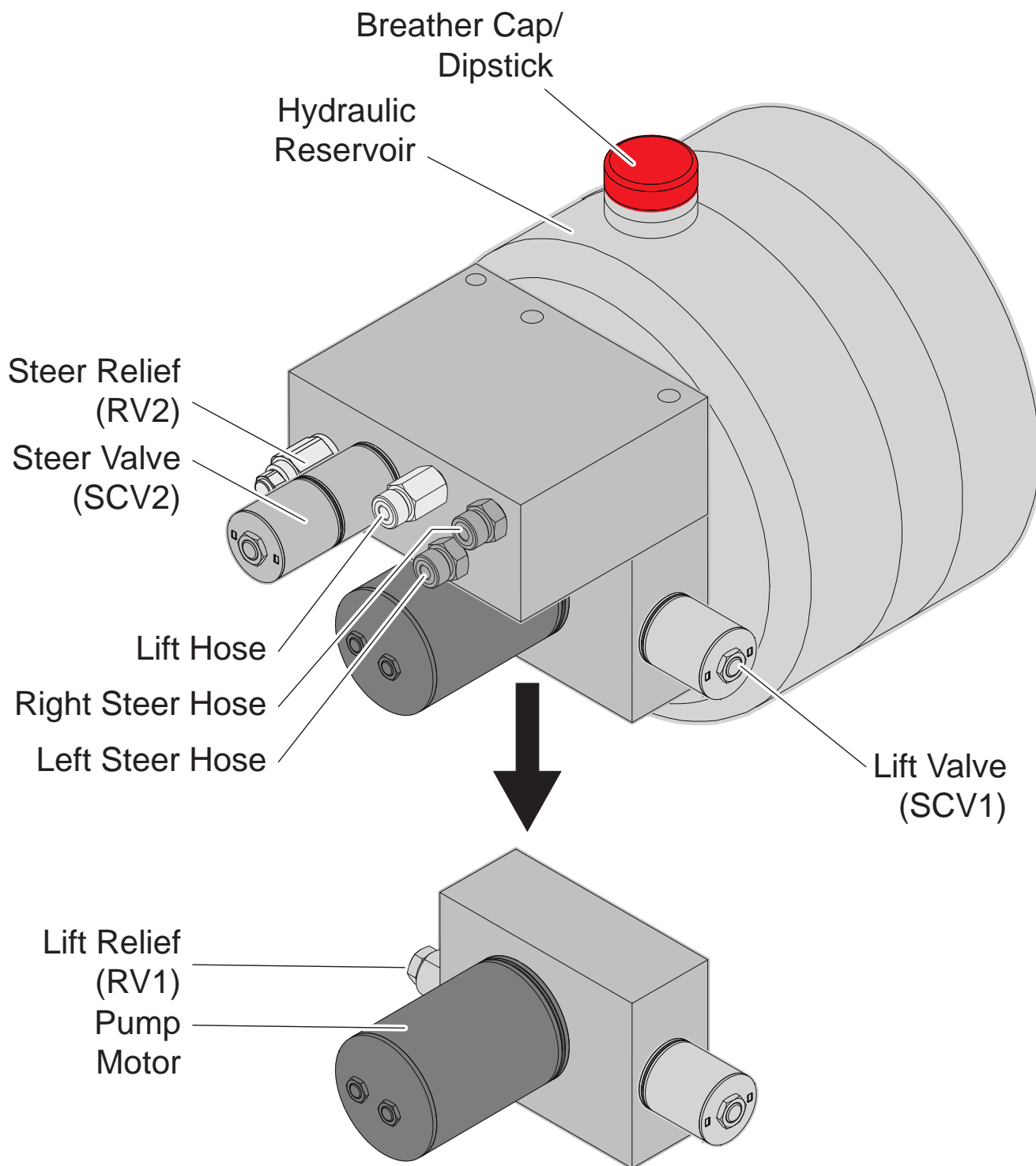

ILLUSTRATION No.  
ART\_5066

## 1330SE HYDRAULIC UNIT



THIS PAGE HAS BEEN INTENTIONALLY LEFT BLANK.

## Parts Introduction

This Parts sections consists of illustrated parts sections and is designed to provide you, the customer, with illustrations and the list of associated parts needed to properly maintain the MEC self-propelled aerial work platform. When used in conjunction with the Service section in this manual and the Operator's Manual (provided separately), this manual will assist you in making necessary adjustments and repairs, and identifying and ordering the correct replacement parts.

All parts represented here are manufactured and supplied in accordance with MEC quality standards.

We recommend that you use genuine MEC parts to ensure proper operation and reliable performance.

To obtain maximum benefits from your MEC Aerial Work Platforms, always follow the proper operating and maintenance procedures. Only trained authorized personnel should be allowed to operate or service this machine. Service personnel should read and study the Operator's, and the Service and Parts Manuals in order to gain a thorough understanding of the unit prior to making any repairs.

# Steer Linkage and Wheels Assembly, To Serial #16102681

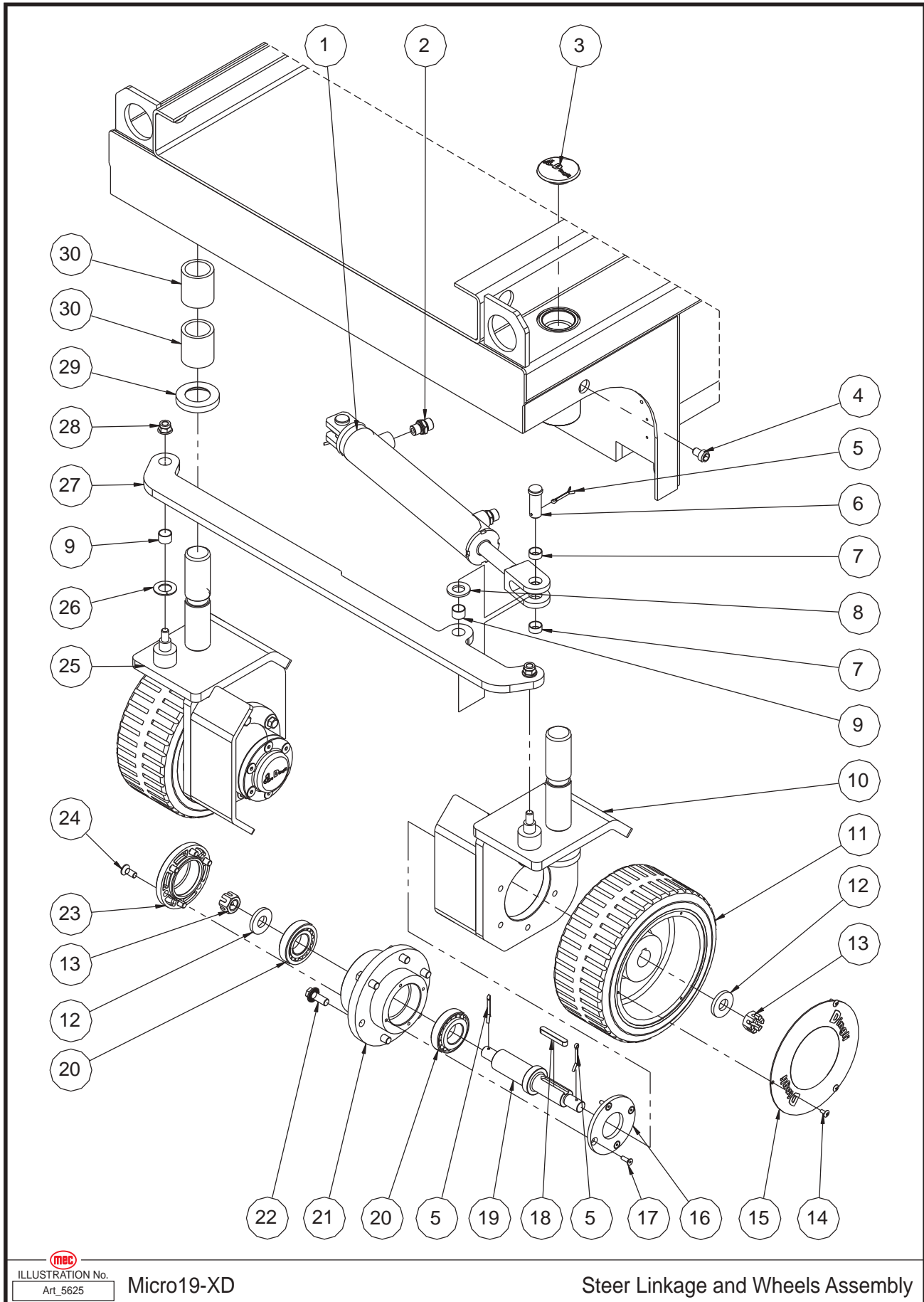

 ILLUSTRATION No. Art\_5625 Micro19-XD

Steer Linkage and Wheels Assembly

Item	Part Number	Description	Qty.
1	41223	Steer Cylinder Assembly	1
--	41594	Seal Kit	1
2	41298	Straight Fitting	2
3	41596	Cover	2
4	41794	Screw	2
5	41322	Cotter Pin	6
6	41321	Pin	2
7	41225	Bearing	4
8	43564	Washer	2
9	41210	Bearing	4
10	43985	Steer Yoke Weldment	1
11	42414	Wheel (To Serial # 16102681)	2
	45265	Wheel (From Serial # 16102682)	2
12	41327	Washer	4
13	53347	Castle Nut M16 x 1.50	4
14	53348	THMS M04-0.70 x 10	6
15	41323	Cover	2
16	41230	Bearing Cover	2
17	53269	CSCS M05-0.80 x 16	8
18	41232	Key	2
19	42415	Wheel Shaft	2
20	41024	Bearing	4
21	41234	Connection Plate	2
22	50429	HHCS M10-1.50 x 25 Serrated Flange	12
23	41328	Cap	2
24	53282	CSCS M08-1.25 x 20	12
25	43986	Steer Yoke Weldment	1
26	41222	Bearing	2
27	42412	Tie Rod	1
28	50311	NNYL M10-1.50 Flange	2
29	41792	Washer	2
30	41595	Bearing	4

# Drive Wheel Assembly, To Serial #16102681

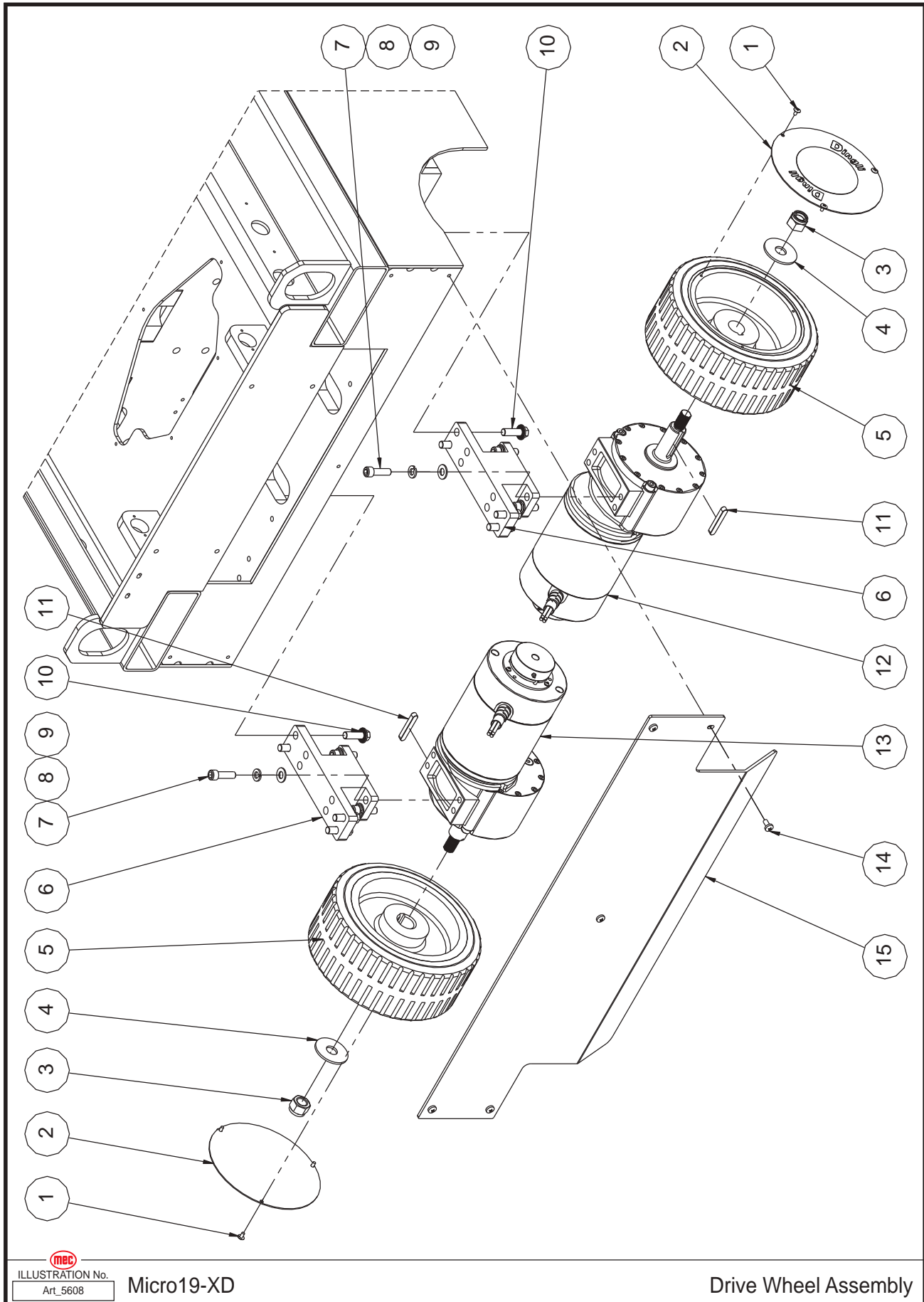

 ILLUSTRATION No. **Micro19-XD**  
Art\_5608

Drive Wheel Assembly

Item	Part Number	Description	Qty.
1	53263	THMS M04-0.70 x 8	6
2	41323	Cover	2
3	53313	NNYL M16 x 1.50	2
4	53314	WSHR M16 Flat Fender	2
5	42414	Wheel (To Serial # 16102681)	2
	45265	Wheel (From Serial # 16102682)	2
6	41239	Support	2
7	53315	SHCS 3/8-24 x 1 1/4	8
8	53316	WSHR 3/8 Spring Washer	8
9	53317	WSHR 3/8 Standard Flat Narrow	8
10	53268	HHCS M10-1.50 x 30 Serrated Flange	8
11	41232	Key	2
12	42421	Right Drive Motor Assembly	1
--	42886	Right Motor	1
--	42889	Brake	1
--	42887	Reducer (To Serial # 16102681)	1
	47472	Reducer (From Serial # 16102682)	1
13	42419	Left Drive Motor Assembly	1
--	42890	Left Motor	1
--	42889	Brake	1
--	42887	Reducer (To Serial # 16102681)	1
	47472	Reducer (From Serial # 16102682)	1
14	53318	PHMS M06-1.00 x 12	5
15	42407	Plate	1
--	42883	Connector, Drive Motor	1

# Steer Linkage and Wheels Assembly, From Serial #16102682

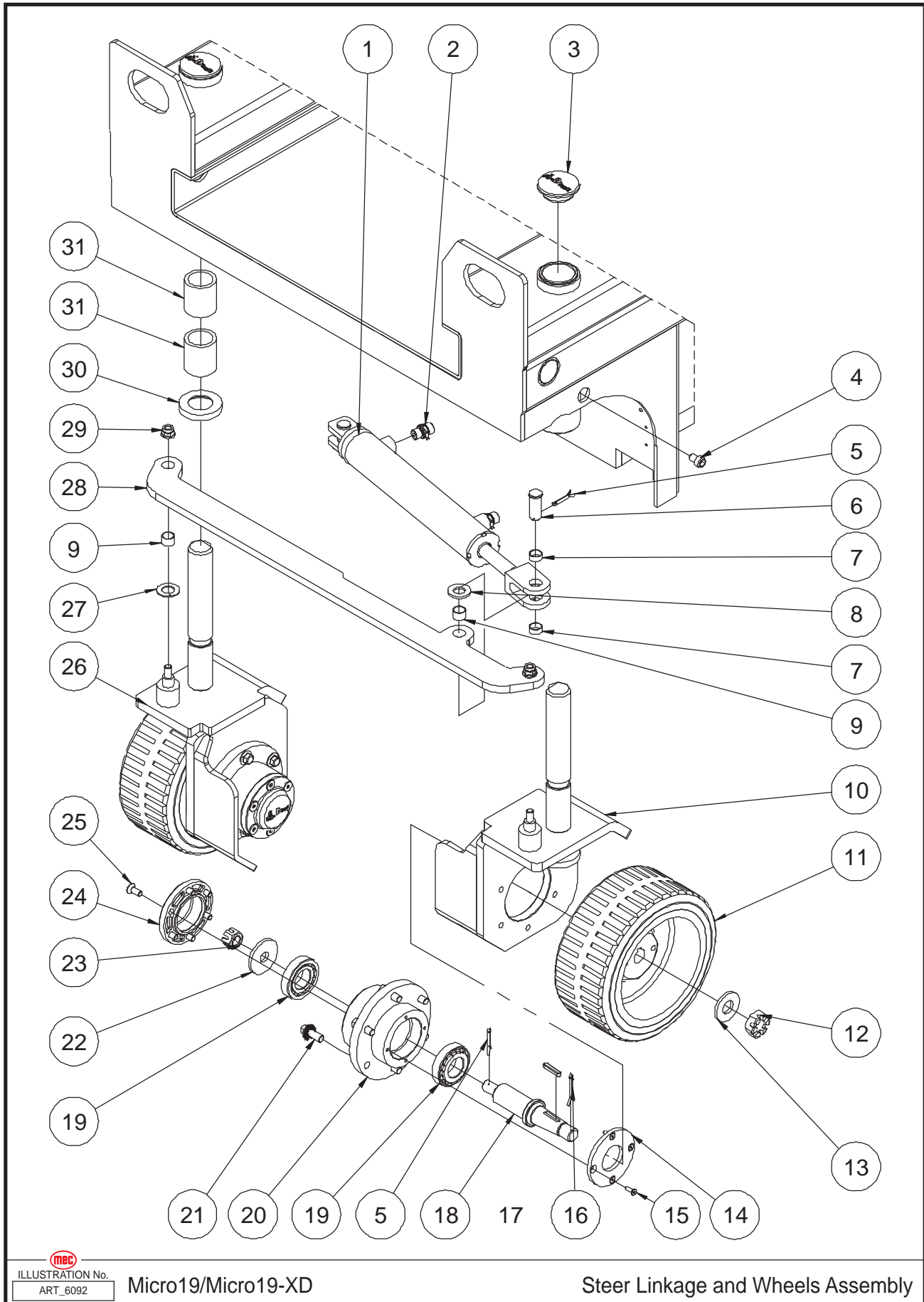

  
ILLUSTRATION No.  
ART\_6092

Micro19/Micro19-XD

Steer Linkage and Wheels Assembly



Item	Part Number	Description	Qty.
1	41223	Steer Cylinder Assembly	1
--	41594	Seal Kit	1
2	41298	Straight Fitting	2
3	41596	Cover	2
4	41794	Screw	2
5	41322	Cotter Pin	4
6	41321	Pin	2
7	41225	Bearing	4
8	43564	Washer	2
9	41210	Bearing	4
10	44607	Steer Yoke Weldment	1
11	45265	Wheel	2
12	46738	Nut	2
13	46739	Washer	2
14	41230	Bearing Cover	2
15	53269	Screw CSCS M05-0.80 x 16	8
16	43563	Cotter Pin	2
17	46745	Key	2
18	47526	Wheel Shaft	2
19	41024	Bearing	4
20	41234	Connection Plate	2
21	50429	Screw HHCS M10-1.50 x 25 Serrated Flange	12
22	41327	Washer	2
23	53347	Castle Nut M16-1.50	2
24	41328	Cap	2
25	53282	Screw CSCS M08-1.25 x 20	12
26	44608	Steer Yoke Weldment	1
27	41222	Bearing	2
28	42412	Tie Rod	1
29	50311	Nut NNYL M10-1.50 Flange	2
30	41792	Washer	2
31	41595	Bearing	4

# Drive Wheel Assembly, From Serial #16102682

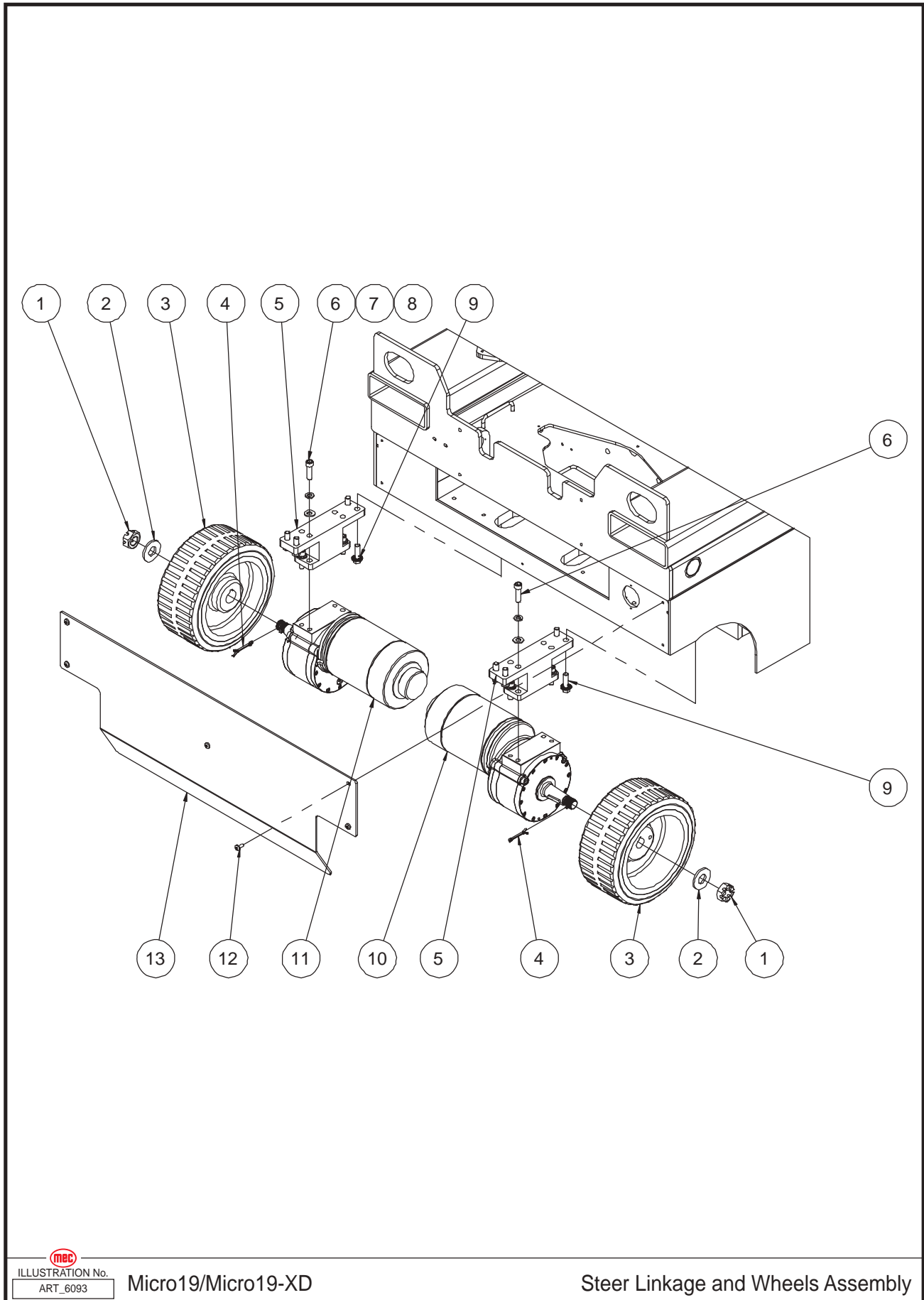

  
ILLUSTRATION No.  
ART\_6093

Micro19/Micro19-XD

Steer Linkage and Wheels Assembly

Item	Part Number	Description	Qty.
1	46738	Nut	2
2	46739	Washer	2
3	45265	Wheel	2
4	43563	Cotter Pin	2
5	41239	Support	2
6	53315	Screw SHCS 3/8-24 x 1 1/4	8
7	53316	WSHR 3/8 Spring Washer	8
8	53317	WSHR 3/8 Standard Flat Narrow Washer	8
9	53268	Screw HHCS M10-1.50 x 30 Serrated Flange	8
10	47527	Right Drive Motor Assembly	1
--	47528	Right Motor	1
--	42889	Brake	1
--	47472	Reducer	1
--	46745	Key	1
11	47529	Left Drive Motor Assembly	1
--	47530	Left Motor	1
--	42889	Brake	1
--	47472	Reducer	1
--	46745	Key	1
12	53318	Screw PHMS M06-1.00 x 12	5
13	42407	Plate	1

# Pothole Protection Assembly

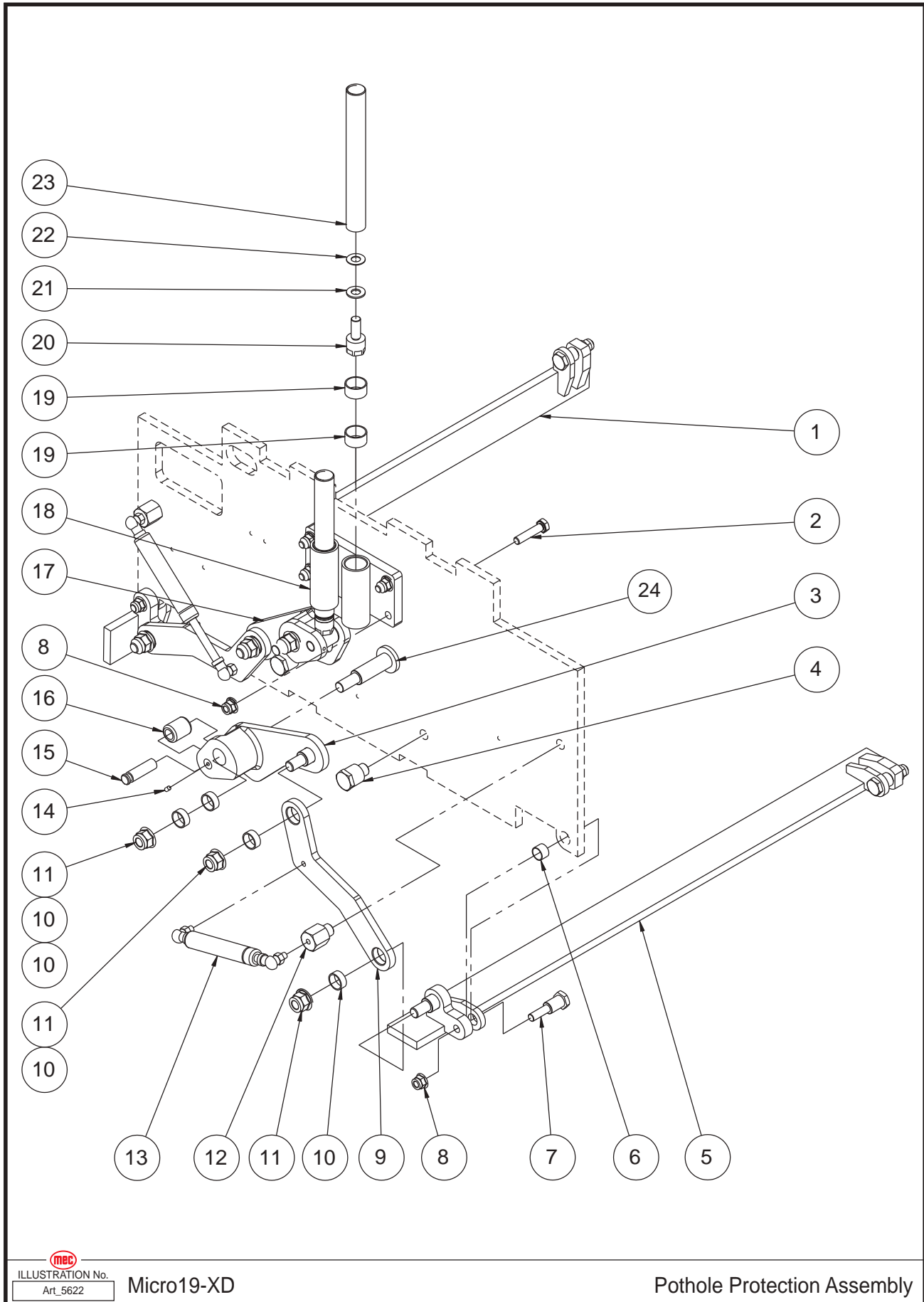

 ILLUSTRATION No. **Micro19-XD**  
Art. 5622

Pothole Protection Assembly

Item	Part Number	Description	Qty.
1	42409	Pothole Guard Weldment	1
2	50430	HHCS M10-1.50 x 45	4
3	41319	Linkage Weldment	1
4	41211	Pin	2
5	42410	Pothole Guard Weldment	1
6	41210	Bearing	4
7	41209	Pin	4
8	50311	NNYL M10-1.50 Flange	8
9	42411	Pothole Link Plate	2
10	41214	Bearing	8
11	53349	NNYL M14-2.00 Flange	6
12	41212	Gas Shock Strut	2
13	41215	Gas Shock	2
14	53283	Set Screw M05-0.80 x 10 Cone Point	2
15	41216	Pin	2
16	41217	Roller	2
17	41320	Linkage Weldment	1
18	41220	Pothole Guide	1
19	41203	Bearing	4
20	41204	Pothole Hole Pusher Pin	2
21	44007	Adjusting Washer 2	2
22	44008	Adjusting Washer 3	2
23	41205	Pothole Hole Pusher Rod	2
24	47376	Pivot Pin, Pothole Weld	1

# Battery Pack Module

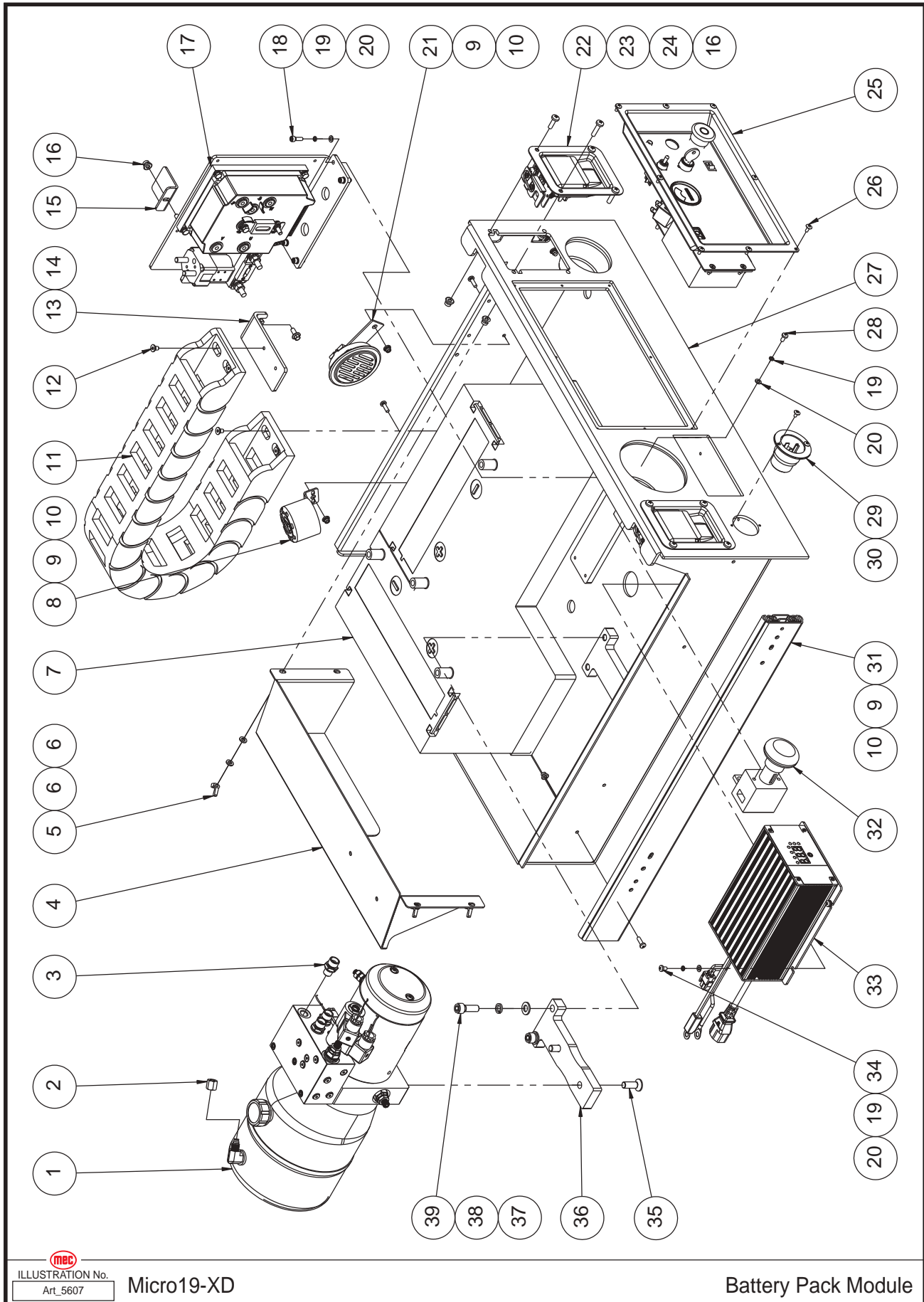

 ILLUSTRATION No. **Micro19-XD**  
Art\_5607

Battery Pack Module

Item	Part Number	Description	Qty.
1	42422	Hydraulic Power Unit (Refer to page 52)	1
2	41413	Nut	1
3	41296	Straight Fitting	3
4	42491	Ground Control Cover	1
5	53350	Wing Nut M06-1.00	4
6	50000	WSHR M06 Standard Flat	4
7	44019	Battery	2
8	41074	Alarm	1
9	53281	NNYL M05-0.80 Flange	8
10	53351	PHMS M05-0.80 x 16	8
11	43987	Towline	1
12	53352	CSCS M06-1.00 x 10	4
13	42430	Towline Bracket	1
14	53273	HHCS M06-1.00 x 14 Serrated Flange	2
15	42431	Press Plate	1
16	50568	NNYL M06-1.00 Flange	9
17	REF	Motor Controller Assembly (Refer to page 54)	1
18	50359	SHCS M05-0.80 x 16	4
19	53043	WSHR M05 Spring Washer	10
20	53038	WSHR M05 Standard Flat	10
21	41075	Horn	1
22	43977	Latch	2
23	53264	PHMS M06-1.00 x 20	4
24	53353	PHMS M06-1.00 x 25	4
25	REF	Ground Control Assembly (Refer to page 56)	1
26	53348	THMS M04-0.70 x 10	8
27	43988	Battery Tray Weldment	1
28	53354	PHMS M05-0.80 x 10	2
29	41575	Plug	1
30	53263	THMS M04-0.70 x 8	2
31	41255	Glide Track	2
32	42071	Emergency Switch	1
33	42904	Charger	1
34	53222	PHMS M05-0.80 x 8	4
35	53225	CSCS M10-1.50 x 30	2
36	41337	Bracket	1
37	50002	WSHR M10 Standard Flat	2
38	53054	WSHR M10 Spring Washer	2
39	50127	SHCS M10-1.50 x 30	2

REF - Reference

# Hydraulic Power Unit

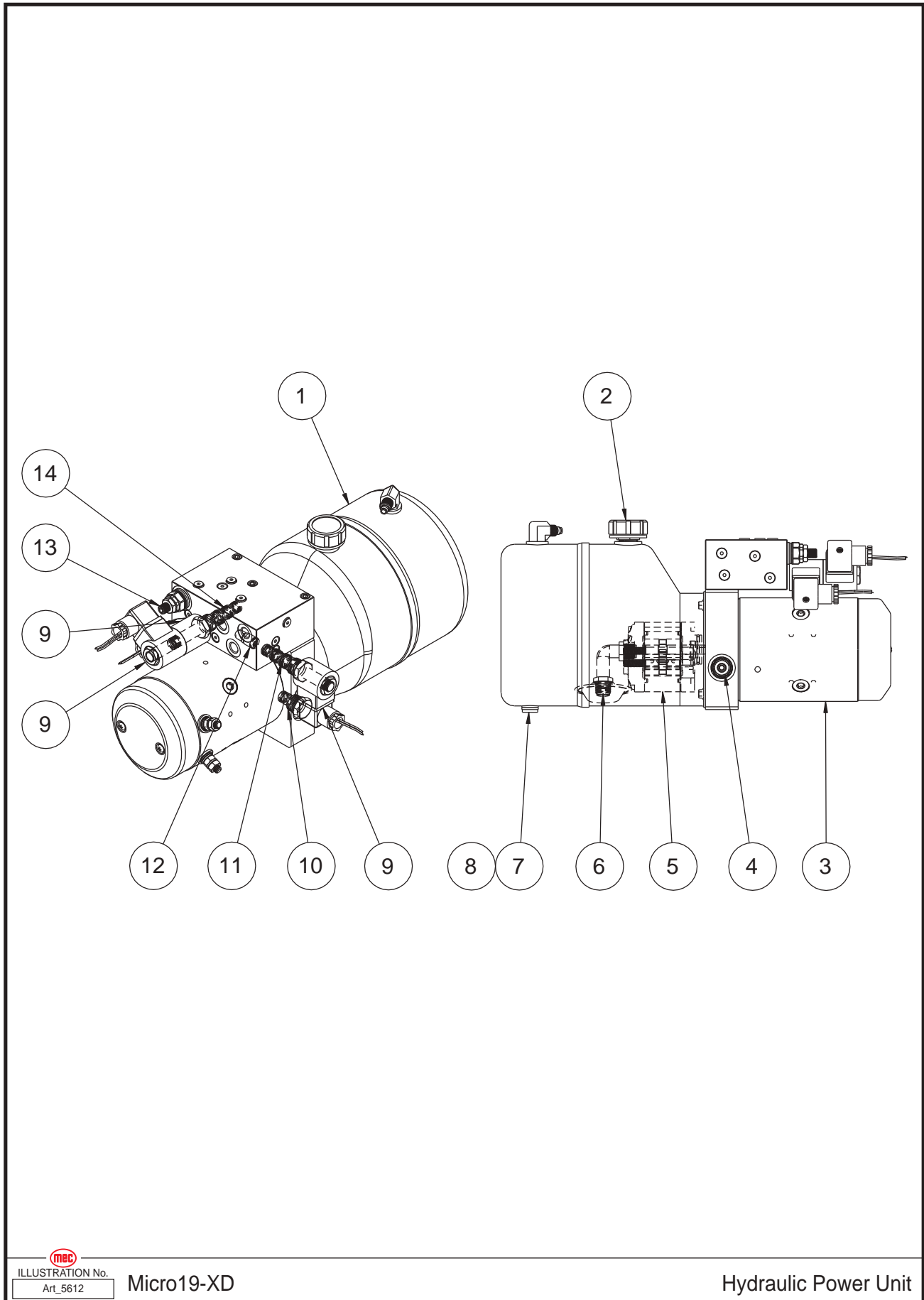

 ILLUSTRATION No. **Micro19-XD**  
Art\_5612

Hydraulic Power Unit



Item	Part Number	Description	Qty.
1	42426	Tank	1
2	43784	Tank Cover	1
3	42424	Motor	1
4	44009	Relief Valve Lift	1
5	42425	Pump	1
6	44010	Filter Web	1
7	43776	Plug	1
8	43777	Washer	1
9	44011	Coil	3
10	44013	Check Valve	1
11	45305	Solenoid Valve Spool Lift	1
12	42427	Pressure Compensation Valve	1
13	44012	Relief Valve Steer	1
14	41246	Solenoid Valve Spool Steer	1

# Motor Controller Assembly

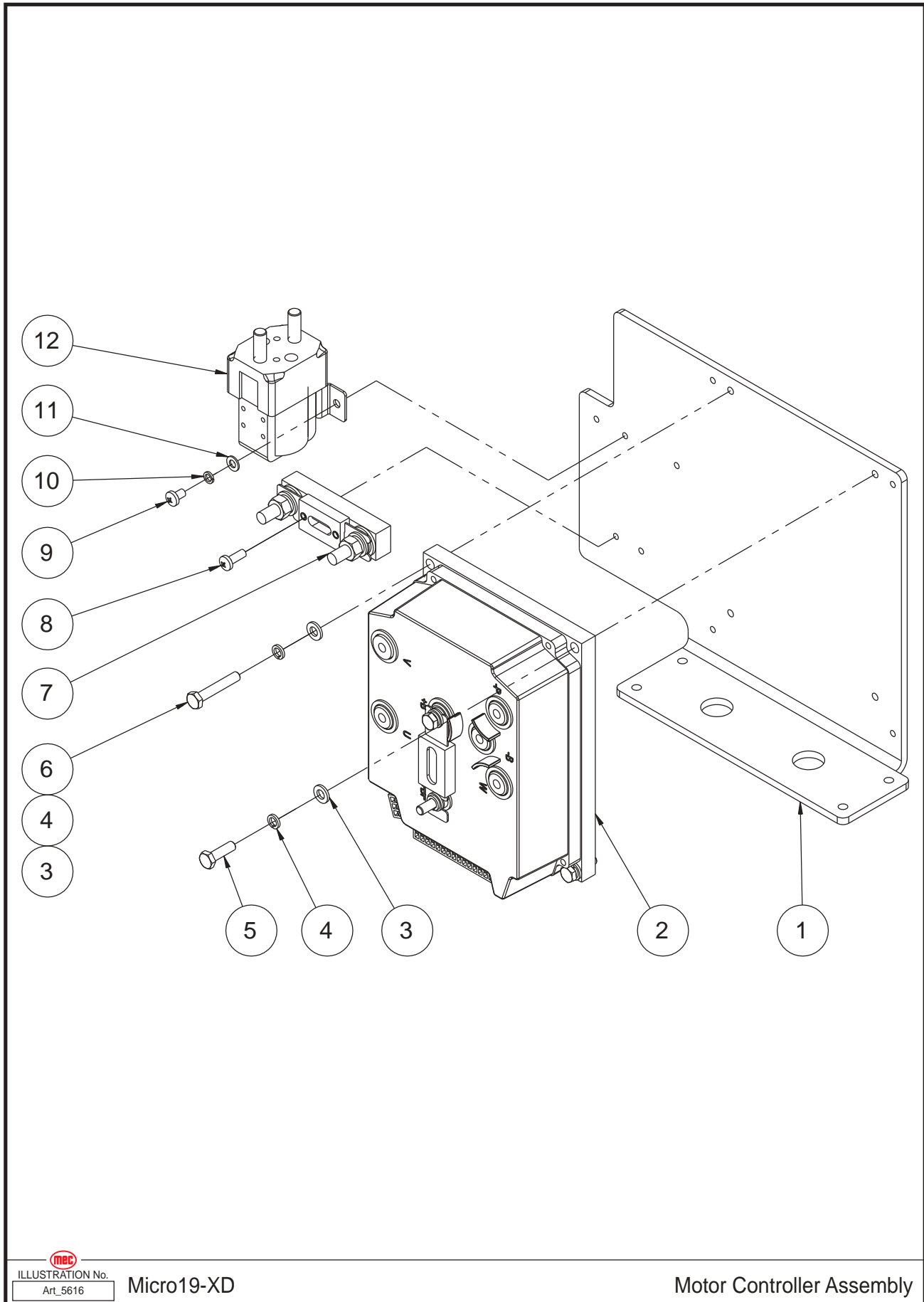

 ILLUSTRATION No. **Micro19-XD**  
Art\_5616

Motor Controller Assembly

Item	Part Number	Description	Qty.
1	42431	Mounting Plate	1
2	41610	Motor Controller	1
3	50000	WSHR M06 Standard Flat	4
4	53046	WSHR M06 Spring Washer	4
5	50028	HHCS M06-1.00 × 20	3
6	50327	HHCS M06-1.00 × 35	1
7	42432	200A Fuse Assembly	1
--	44014	200A Fuse	1
--	41092	Fuse Seat	1
8	53355	PHMS M05-0.80 × 14	2
9	53222	PHMS M05-0.80 × 8	2
10	53043	WSHR M05 Spring Washer	2
11	53038	WSHR M05 Standard Flat	2
12	41331	DC Contactor	1

# Ground Control Assembly

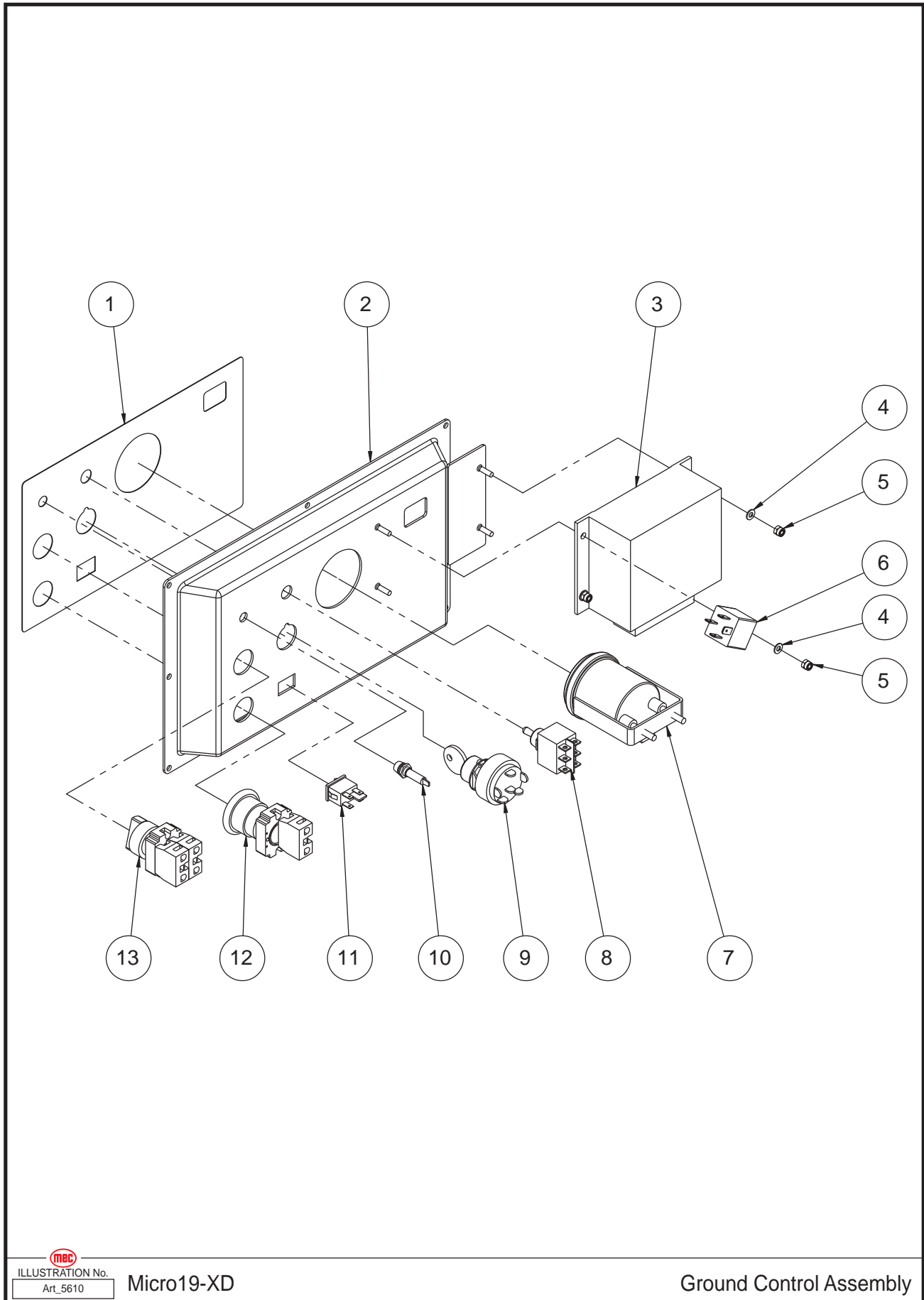

 ILLUSTRATION No. **Micro19-XD**  
Art\_5610

Ground Control Assembly

Item	Part Number	Description	Qty.
1	43903	Decal, Ground Control Panel	1
2	43990	Ground Control Panel Weldment	1
3	44580	Controller	1
4	50284	WSHR M04 Standard Flat	4
5	50285	NNYL M04 x 0.70	4
6	41334	Relay	1
7	41070	Hour Meter	1
8	41419	Toggle Switch	1
9	41418	Key Switch	1
--	91574	Key	1
10	41421	Indicator	1
11	43991	Brake Release Switch	1
12	41422	Emergency Stop Switch	1
--	43098	Red Mushroom Head	1
--	43097	Base With 1 NC Contact	1
13	43992	Select Switch	1
--	43993	Select Switch Head	1
--	43994	Base With 1 NO Contact	1
--	43096	NC Contact	1

# Ladder and Accessories

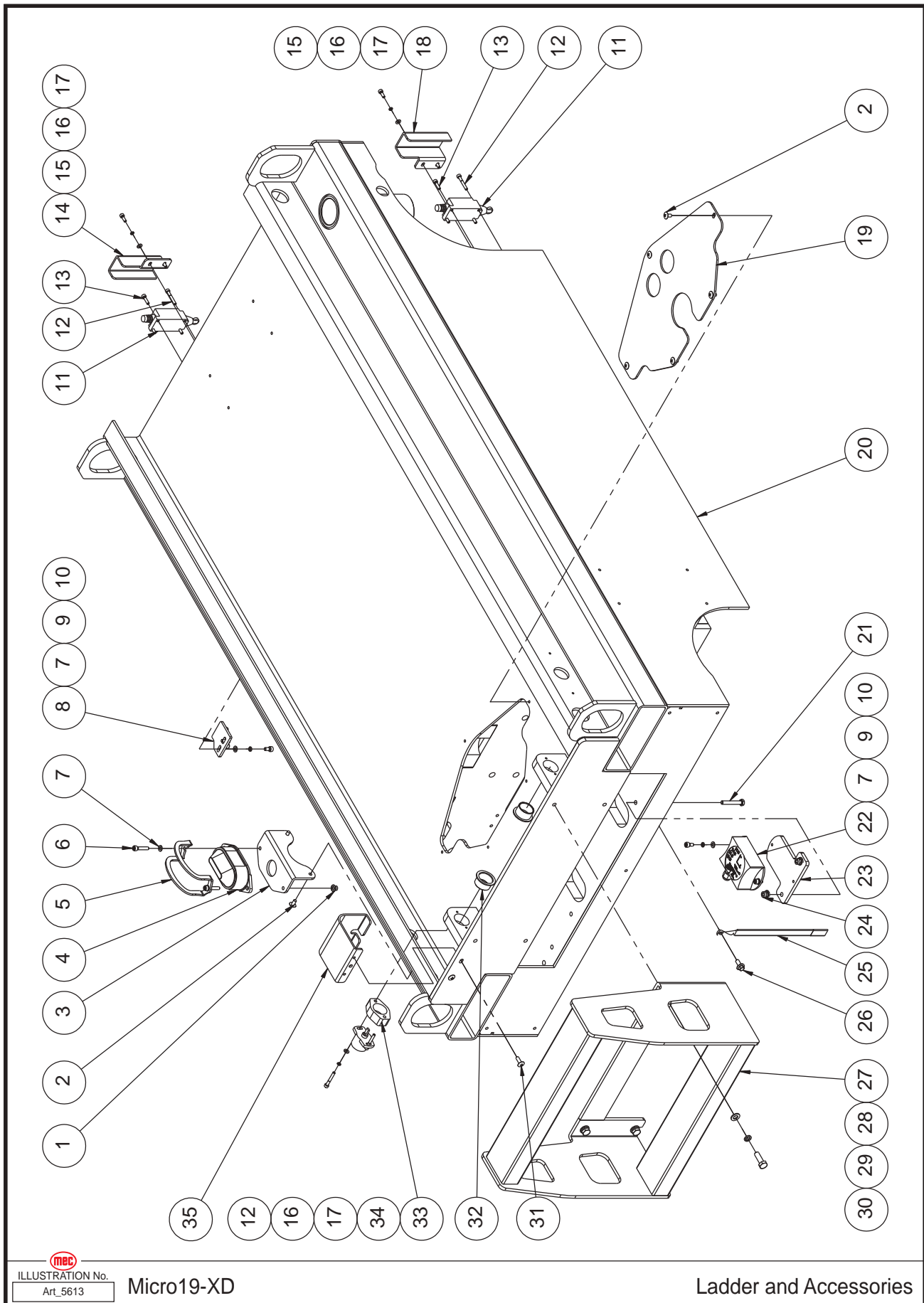

ILLUSTRATION No. **Micro19-XD**  
Art. 5613

Ladder and Accessories

Item	Part Number	Description	Qty.
1	53281	NNYL M05-0.80 Flange	2
2	53265	THMS M05-0.80 × 10	7
3	42406	Beacon Bracket	1
4	41310	Beacon	1
5	41309	Beacon Cover	1
6	53356	SHCS M05-0.80 × 25	2
7	53038	WSHR M05 Standard Flat	8
8	43978	Lock	2
9	53043	WSHR M05 Spring Washer	6
10	53173	SHCS M05-0.80 × 10	6
11	41197	Limit Switch	2
12	53065	SHCS M04-0.70 × 30	6
13	53113	SHCS M04-0.70 × 16	4
14	41315	Switch Cover	1
15	50423	SHCS M04-0.70 × 12	4
16	53062	WSHR M04 Spring Washer	6
17	50284	WSHR M04 Standard Flat	6
18	41198	Switch Cover	1
19	42401	Cover	1
20	43995	Frame Weldment	1
21	50289	HHCS M06-1.00 × 40	2
22	41098	Tilt Sensor	1
23	42403	Sensor Bracket	1
24	50568	NNYL M06-1.00 Flange	2
25	41003	Ground Strap	1
26	53273	HHCS M06-1.00 × 14 Serrated Flange	1
27	42405	Ladder	1
28	50001	WSHR M08 Standard Flat	4
29	53055	WSHR M08 Spring Washer	4
30	50031	HHCS M08-1.25 × 25	4
31	53223	THMS M05-0.80 × 16	2
32	41257	Bearing	2
33	41194	Sensor Bracket	1
34	41195	Rotary Sensor	1
35	42885	Sensor Cover	1

# Scissor Assembly

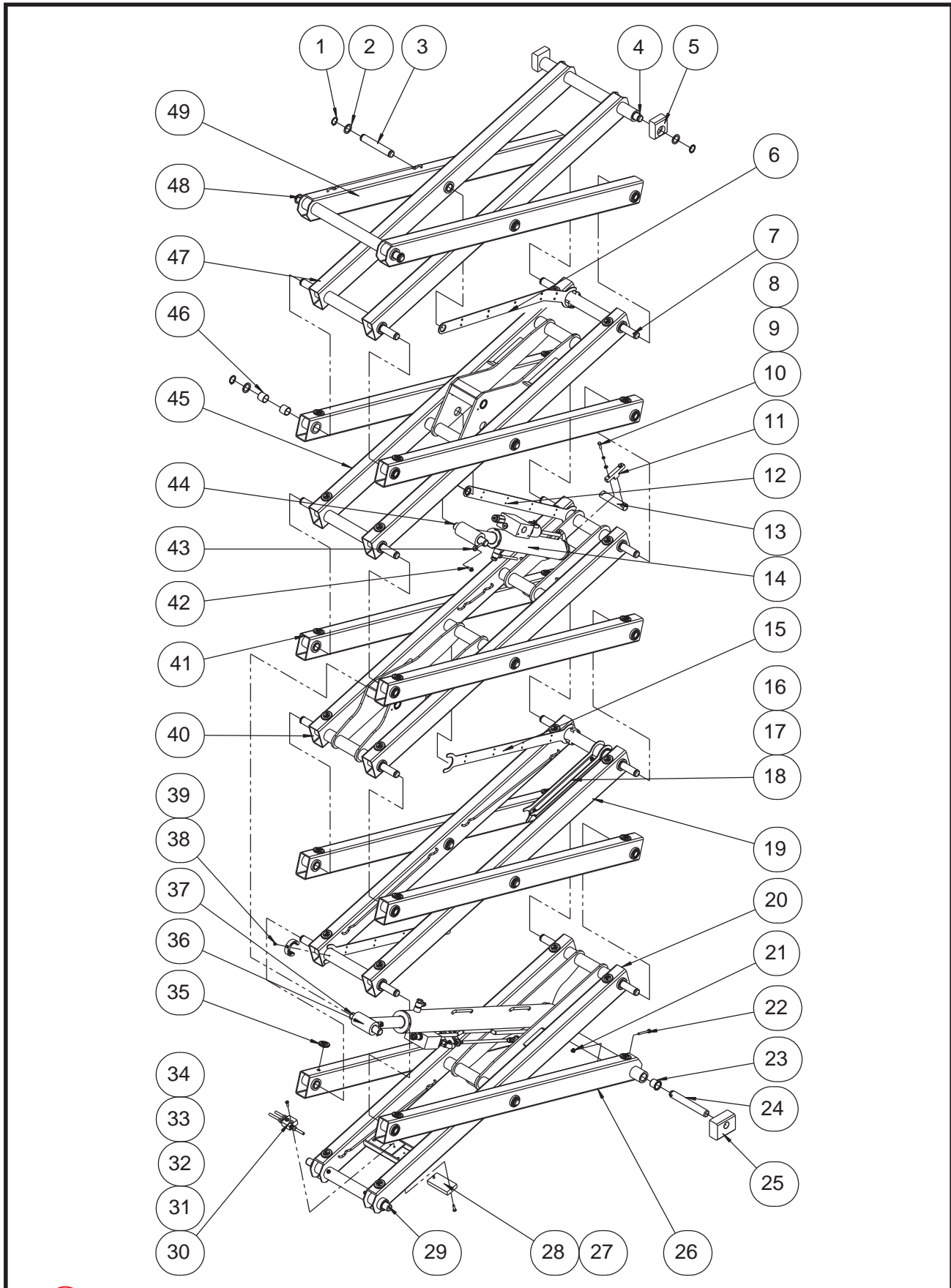

 ILLUSTRATION No. **Micro19-XD**  
Art\_5624

Scissor Assembly



Item	Part Number	Description	Qty.
1	42437	Circlips	36
2	41354	Washer	34
3	41349	Pin	6
4	41576	Pin	1
5	41256	Platform Slider	2
6	43744	Cable Bridge	1
7	41577	Pin	10
8	53123	SHCS M06-1.00 × 25	4
9	53046	WSHR M06 Spring Washer	4
10	50000	WSHR M06 Standard Flat	4
11	42439	Lock Plate	2
12	42438	Cable Bridge	1
13	42440	Pin	1
14	REF	Upper Lift Cylinder Assembly (Refer to page 82)	1
15	42442	Cable Bridge	2
16	41262	Safety Arm Bushing	2
17	41263	Safety Arm	2
18	53255	HHCS M06-1.00 × 20 Serrated Flange	2
19	42443	Inner Arm 2	1
20	43996	Inner Arm 1	1
21	53357	HHCS M06-1.00 × 55 Flange	4
22	50568	NNYL M06-1.00 Flange	6
23	42446	Bearing	28
24	41338	Pin	2
25	42447	Chassis Slider	2
26	42448	Outer Arm 1	1
27	50386	CSCS M06-1.00 × 25	2
28	41350	Pothole Pusher	1
29	41258	Pin	1
30	41112	Hydraulic Hoses Manifolds	1
31	43601	Hose (To Upper Lift Cylinder)	1
32	43997	Hose (To Lower Lift Cylinder)	1
33	44015	Hose (To Hydraulic Tank)	1
34	50561	CSCS M06-1.00 × 20	2
35	41114	Block	32
36	REF	Lower Lift Cylinder Assembly (Refer to page 80)	1
37	41345	Pin	2
38	53279	CSCS M05-0.80 × 12	3
39	41582	Collar	3
40	42452	Inner Arm 3	1
41	42453	Outer Arm 2	6
42	53256	HHCS M06-1.00 × 16 Serrated Flange	3
43	42449	Pin	3
44	42454	Pin	1
45	43998	Inner Arm 4	1

46	41287	Bearing	64
47	42456	Inner Arm 5	1
48	42457	Pin	1
49	42458	Outer Arm 5	1

REF - Reference

THIS PAGE HAS BEEN INTENTIONALLY LEFT BLANK.

# Main Platform Assembly, Folding Rails

(To Serial #16100600)

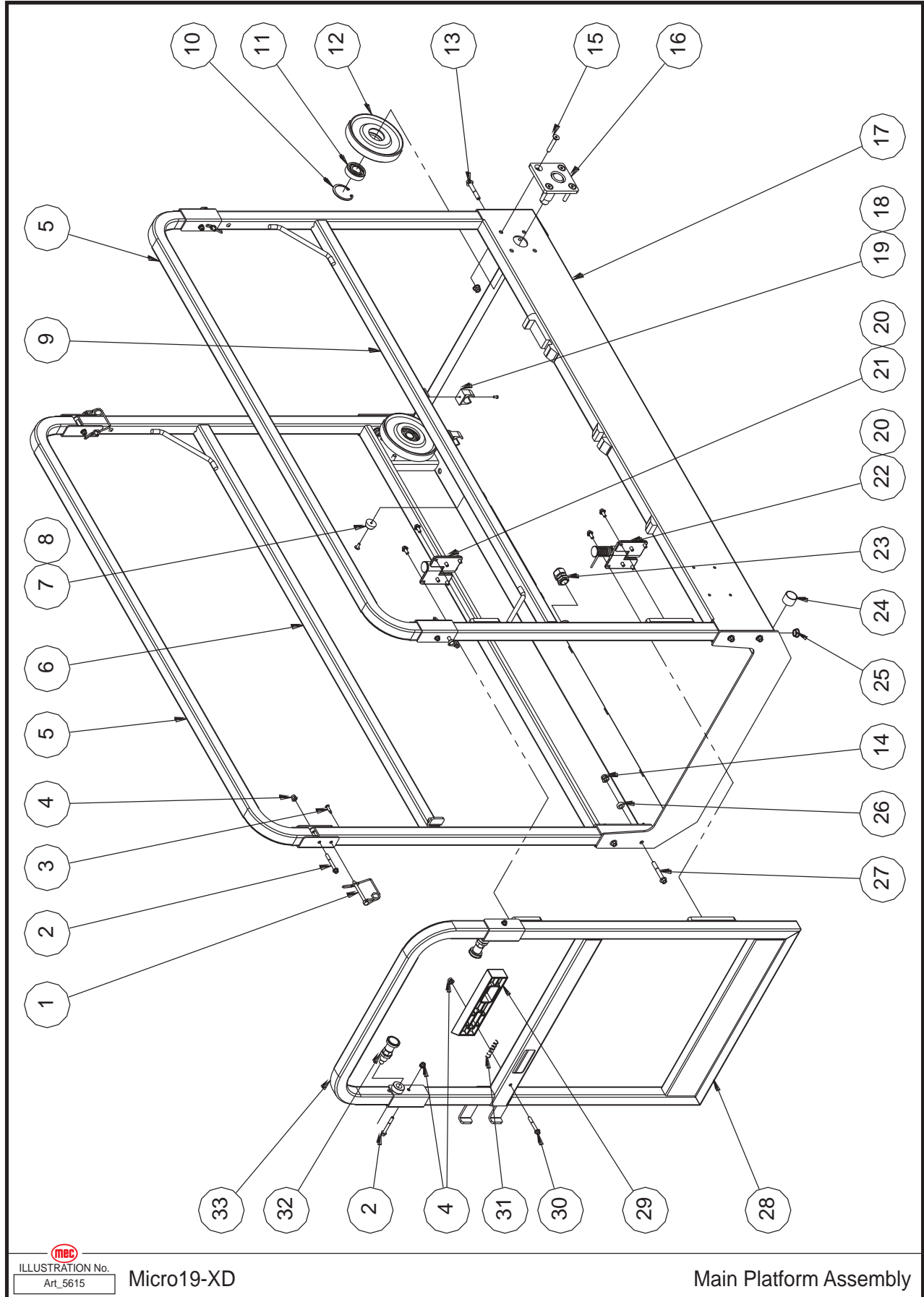

ILLUSTRATION No.  
Art\_5615

Micro19-XD

Main Platform Assembly

Item	Part Number	Description	Qty.
1	41357	Inserted Pin	4
2	53274	HHCS M06-1.00 x 50 Flange	6
3	43301	Rivet	4
4	50568	NNYL M06-1.00 Flange	7
5	44209	Upper Main Rail	2
6	44193	Lower Main Rail, Left	1
7	41120	Bumper	1
8	53224	THMS M05-0.80 x 12	1
9	44206	Lower Main Rail, Right	1
10	43618	Circlips	2
11	41131	Bearing	2
12	41269	Roller	2
13	53358	HHCS M08-1.25 x 50 Flange	4
14	50313	NNYL M08-1.25 Flange	8
15	53275	CSCS M08-1.25 x 45	8
16	41360	Roller Bracket	2
17	42461	Main Deck Weldment	1
18	53276	PHMS M04-0.70 x 8	2
19	41134	Clip	2
20	53273	HHCS M06-1.00 x 14 Serrated Flange	12
21	41127	Hinge A	1
22	41128	Hinge B	1
23	41273	Water-Proof Joint	1
24	41046	Bearing	2
25	41275	Sheath	1
26	42462	Washer	4
27	53359	HHCS M08-1.25 x 55 Flange	4
28	44194	Entry Gate	1
29	41278	Latch Handle	1
30	53360	HHCS M06-1.00 x 45 Flange	1
31	41277	Spring	1
32	95300	Lock Pin	2
33	44192	Door Rail	1

# Main Platform Assembly, Fixed Rails

(From Serial #16100601)

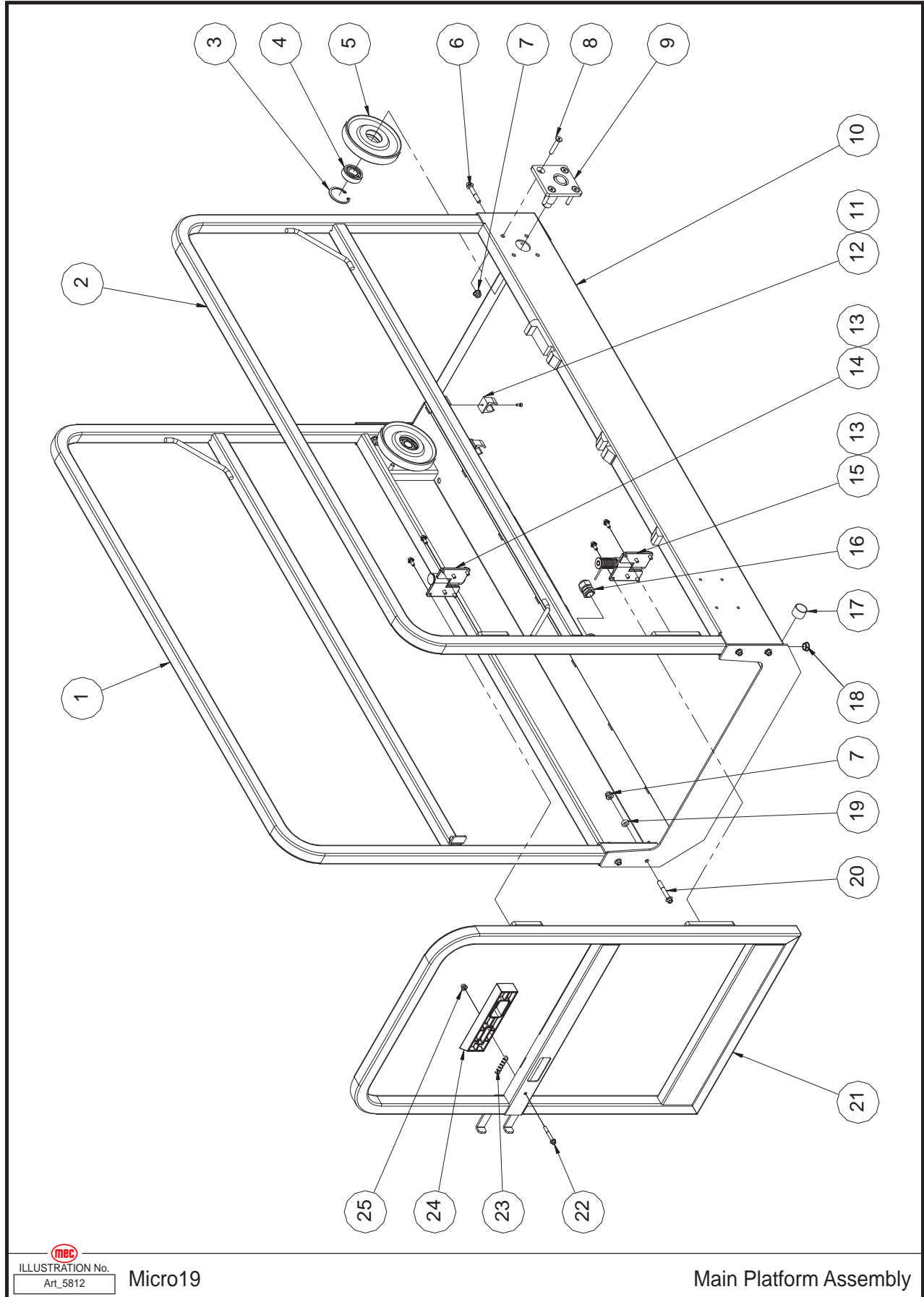

  
ILLUSTRATION No.  
Art\_5812

Micro19

Main Platform Assembly

Item	Part Number	Description	Qty.
1	44810	Left Main Rail	1
2	44811	Right Main Rail	1
3	43618	Circlips	2
4	41131	Bearing	2
5	41269	Roller	2
6	53358	Screw HHCS M08-1.25 x 50 Flange	4
7	50313	Nut NNYL M08-1.25 Flange	8
8	53275	Screw CSCS M08-1.25 x 45	8
9	41360	Roller Bracket	2
10	42461	Main Deck Weldment	1
11	53276	Screw PHMS M04-0.70 x 8	2
12	41134	Clip	2
13	53273	Screw HHCS M06-1.00 x 14 Serrated Flange	12
14	41127	Hinge A	1
15	41128	Hinge B	1
16	41273	Water-Proof Joint	1
17	41046	Bearing	2
18	41275	Sheath	1
19	42462	Washer	4
20	53359	Screw HHCS M08-1.25 x 55 Flange	4
21	44584	Entry Gate	1
22	53360	Screw HHCS M06-1.00 x 45 Flange	1
23	41277	Spring	1
24	41278	Latch Handle	1
25	50568	Nut NNYL M06-1.00 Flange	1

# Platform Extension Assembly, Old Style

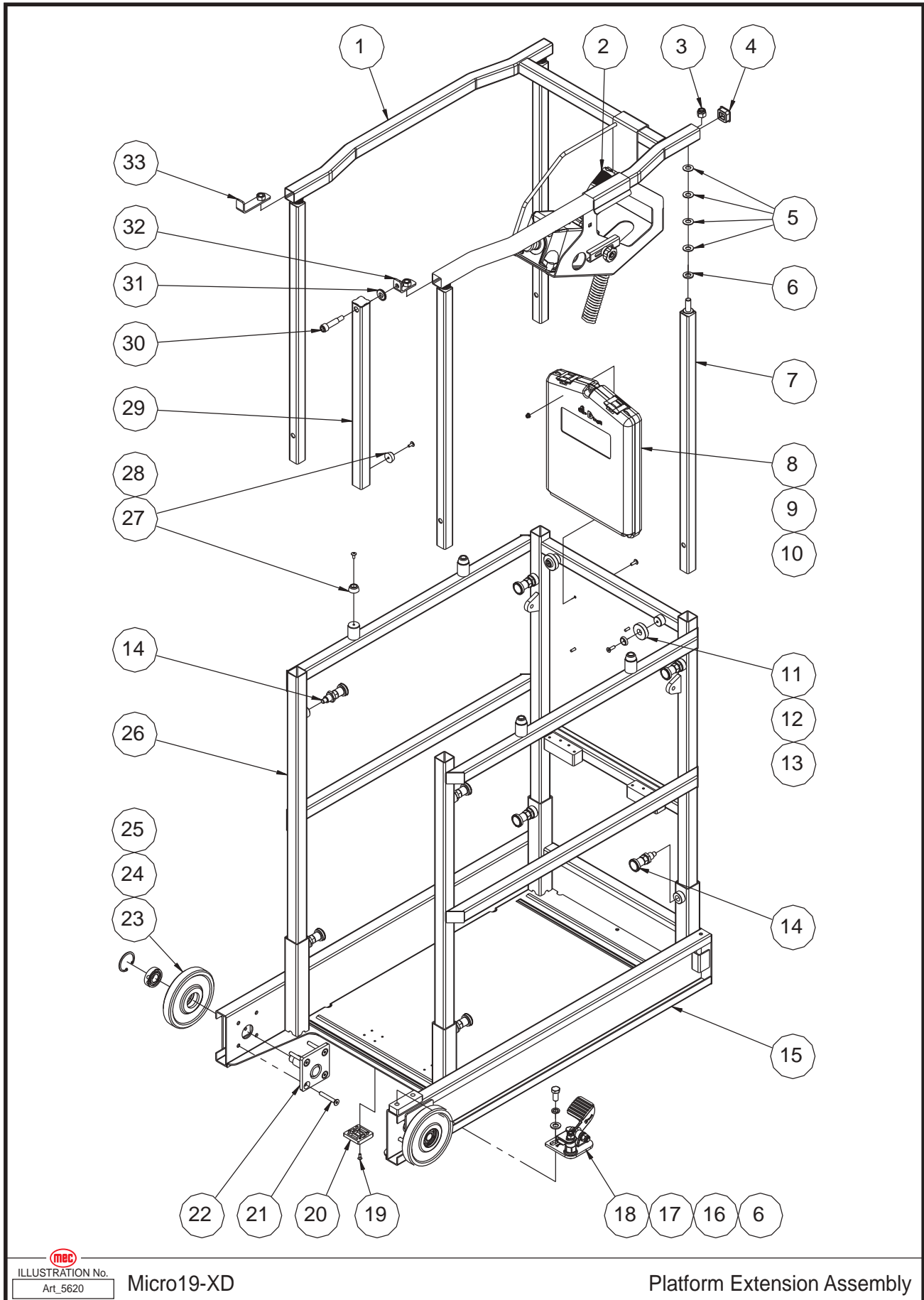

 ILLUSTRATION No. **Micro19-XD**  
Art\_5620

Platform Extension Assembly



Item	Part Number	Description	Qty.
1	44217	Extension Deck Upper Rails Weldment	1
2	44020	Platform Control Assembly (Refer to page 72)	1
3	50050	NNYL M12 x 1.75	2
4	93216	1.25" x .075/.083" Square Tube Cap	2
5	53307	WSHR Belleville 1.00 OD X 0.5 ID	16
6	50003	WSHR M12 Standard Flat	6
7	44176	Telescopic Rail	4
8	43319	Manual Box	1
9	53223	THMS M05-0.80 x 16	4
10	53281	NNYL M05-0.80 Flange	4
11	94981	Encased Magnetic Disc	2
12	95321	Nylon Plastic Countersunk Washer	2
13	50561	CSCS M06-1.00 x 20	2
14	95401	Plunger Pin	8
15	44187	Micro 19 Extension Deck Base	1
16	53148	WSHR M12 Spring Washer	2
17	50038	HHCS M12-1.50 x 25	2
18	REF	Platform Locking Device Assembly (Refer to page 76)	1
19	53279	CSCS M05-0.80 x 12	8
20	41284	Slide Pad	2
21	53280	CSCS M08-1.25 x 55	8
22	41360	Roller Bracket	2
23	41141	Roller 2	2
24	41131	Bearing	2
25	43618	Circlips	2
26	44496	MICRO19-XD Lower Guardrail	1
27	41120	Bumper	5
28	53224	THMS M05-0.80 x 12	5
29	44245	Deck Guard Weldment	1
30	53337	SHSS 12 SHLDR DIA X 40 SHLDR LG X M10 SS	1
31	50006	WSHR M10 ZP Nordlock	1
32	44227	Deck Guard Hinge Bracket	1
33	44237	Deck Guard Latch Rest	1

# Platform Extension Assembly, New Style

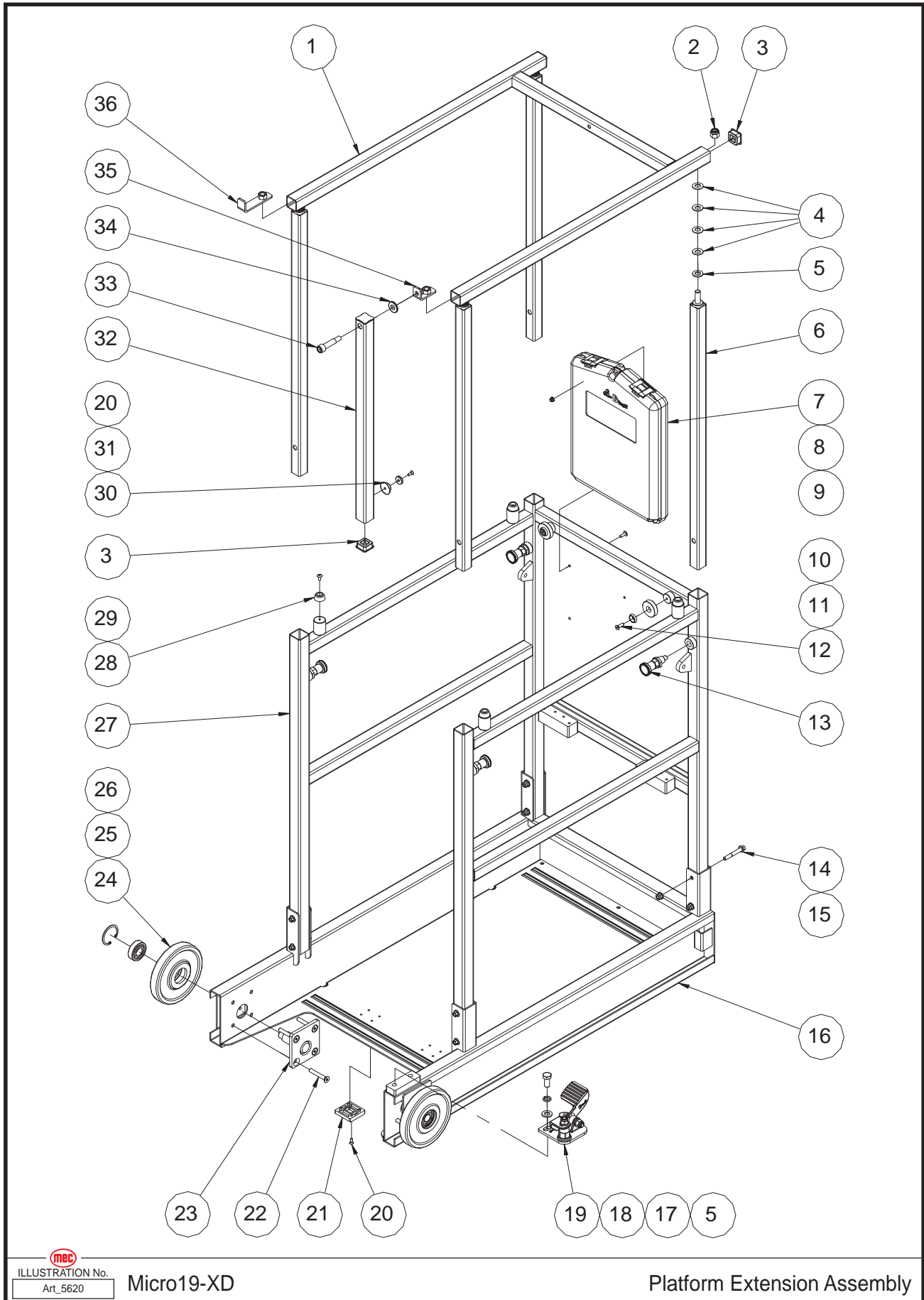

 ILLUSTRATION No. **Micro19-XD**  
Art\_5620

Platform Extension Assembly

Item	Part Number	Description	Qty.
1	44140	Upper Extension Rail	1
2	50050	Nut NNYL M12 x 1.75	2
3	93216	1.25" x .075/.083" Square Tube Cap	3
4	53307	WSHR Belleville 1.00 OD X 0.5 ID	16
5	50003	WSHR M12 Standard Flat Washer	6
6	44176	Telescopic Rail	4
7	43319	Manual Box	1
8	53223	Screw THMS M05-0.80 x 16	4
9	53281	Nut NNYL M05-0.80 Flange	4
10	94981	Encased Magnetic Disc With Mounting Hole	2
11	95321	Nylon Plastic Countersunk Washer For 1/4 Screw	2
12	50561	Screw CSCS M06-1.00 x 20	2
13	44016	Lock Pin	4
14	53359	Screw HHCS M08-1.25 x 55 Flange	8
15	50313	Nut NNYL M08-1.25 Flange	8
16	44818	Extension Deck Weldment	1
17	53148	WSHR M12 Spring Washer	2
18	50038	Screw HHCS M12-1.50 x 25	2
19	REF	Platform Locking Device Assembly (Refer to page 76)	1
20	53279	Screw CSCS M05-0.80 x 12	9
21	41284	Slide Pad	2
22	53280	Screw CSCS M08-1.25 x 55	8
23	41360	Roller Bracket	2
24	41141	Roller 2	2
25	41131	Bearing	2
26	43618	Circlips	2
27	44585	Lower Extension Rail	1
28	41120	Bumper	5
29	53224	Screw THMS M05-0.80 x 12	5
30	44239	Deck Guard Arm Magnet Bushing	1
31	95330	Cup Magnet	1
32	44244	Rear Extension Rail	1
33	53337	SHSS 12 SHLDR DIA X 40 SHLDR LG X M10 SS	1
34	44823	Washer	1
35	44237	Deck Guard Latch Rest Weldment	1
36	44227	Deck Guard Hinge Weldment	1

# Platform Control Assembly

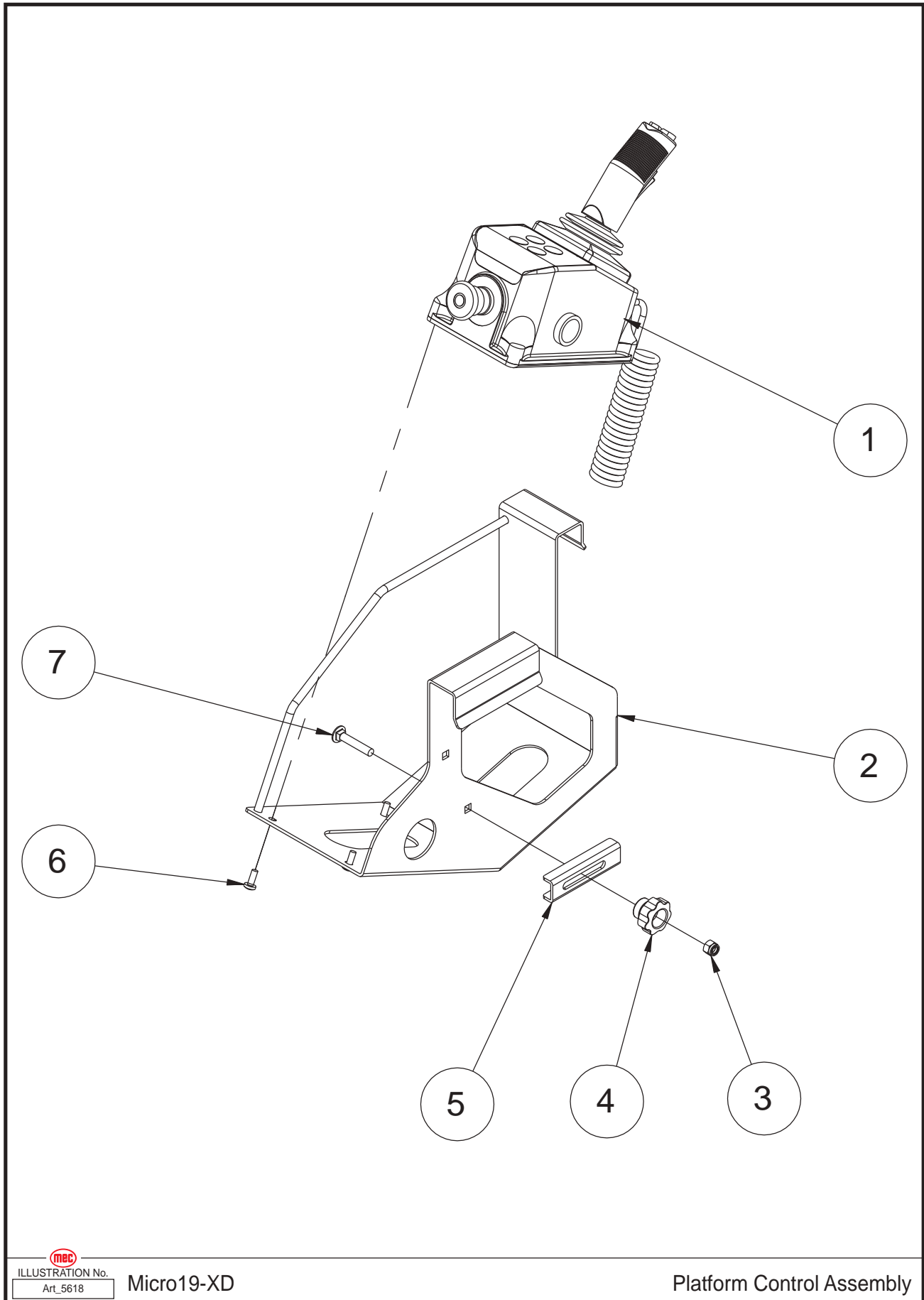

 ILLUSTRATION No. **Micro19-XD**  
Art\_5618

Platform Control Assembly

<b>Item</b>	<b>Part Number</b>	<b>Description</b>	<b>Qty.</b>
1	41137	Platform Control Box Assembly (Refer to page 74)	1
2	42499	Platform Control Box Mount Bracket	1
3	50048	NNYL M08 x 1.25	1
4	42501	Handle	1
5	42500	Locating Plate	1
6	53231	PHMS M06-1.00 x 16	4
7	53248	CARB M08-1.25 x 45	1
--	41271	Connector Kit	1

# Platform Control Box Assembly

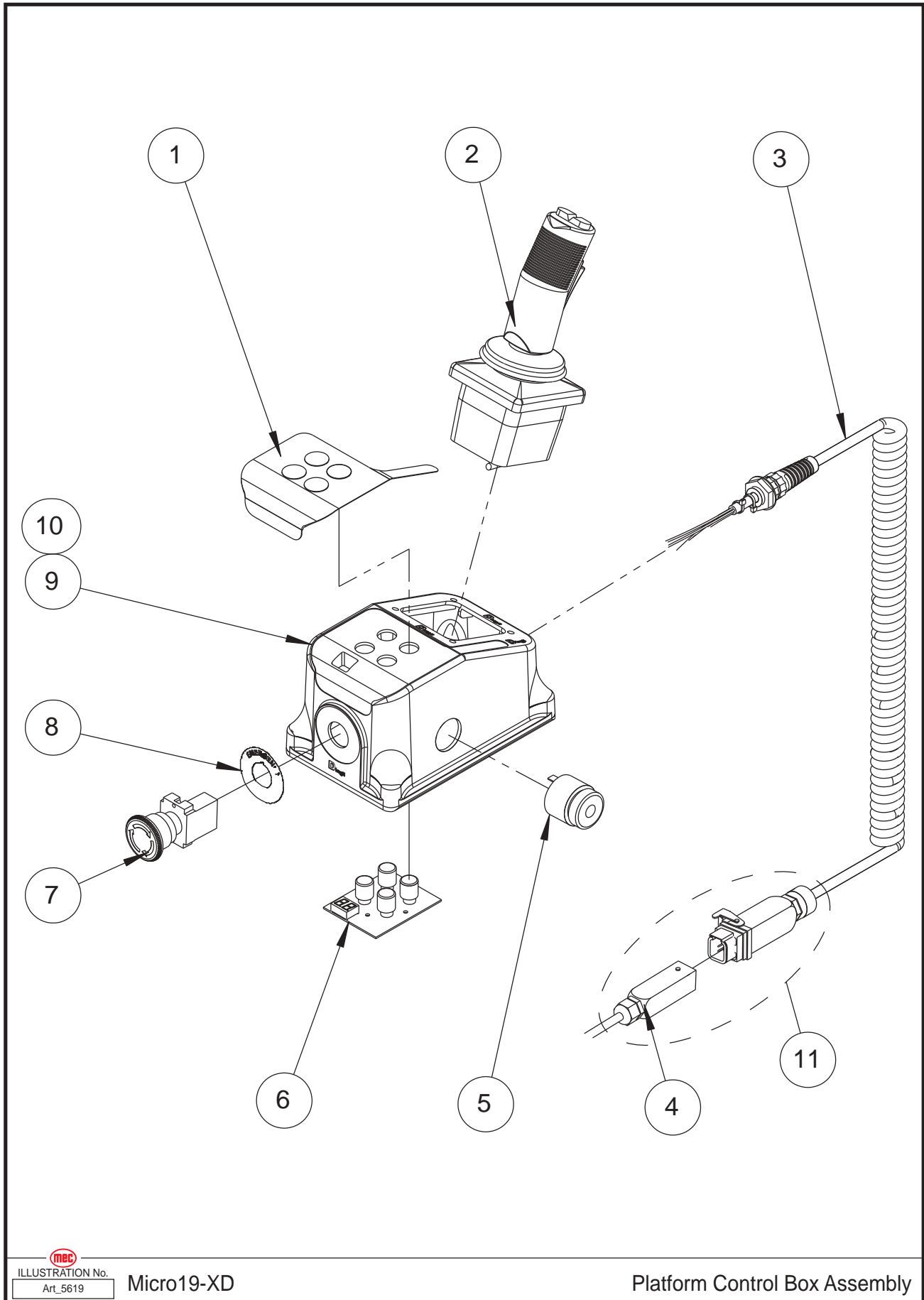

 ILLUSTRATION No. **Micro19-XD**  
Art\_5619

Platform Control Box Assembly

Item	Part Number	Description	Qty.
1	41632	Decal, Platform Control Panel	1
2	41149	Joystick	1
--	43621	Function Enable Switch	1
--	41150	Joystick Cover	1
--	43622	Joystick Steer Switch	1
--	43623	Switch Boot	1
3	41152	Coil Cord	1
--	43624	Housing	1
--	43625	Male Insert	1
--	43626	Male Contacts	5
--	43627	Cable Gland	1
4	43999	Platform Control Box Harness	1
--	43628	Hood	1
--	43629	Female Insert	1
--	43630	Female Contacts	5
--	43627	Cable Gland	1
5	41568	Alarm	1
--	43631	Alarm Nut	1
6	41156	Main Board	1
--	41155	Button	4
7	41157	Emergency Stop Switch	1
--	43632	Red Mushroom Head	1
--	43633	Base With 1 NC Contact	1
8	42915	Decal, Emergency Stop Panel	1
9	43634	Enclosure	1
10	43635	Cover Bottom	1
11	--	--	--

# Platform Locking Device Assembly

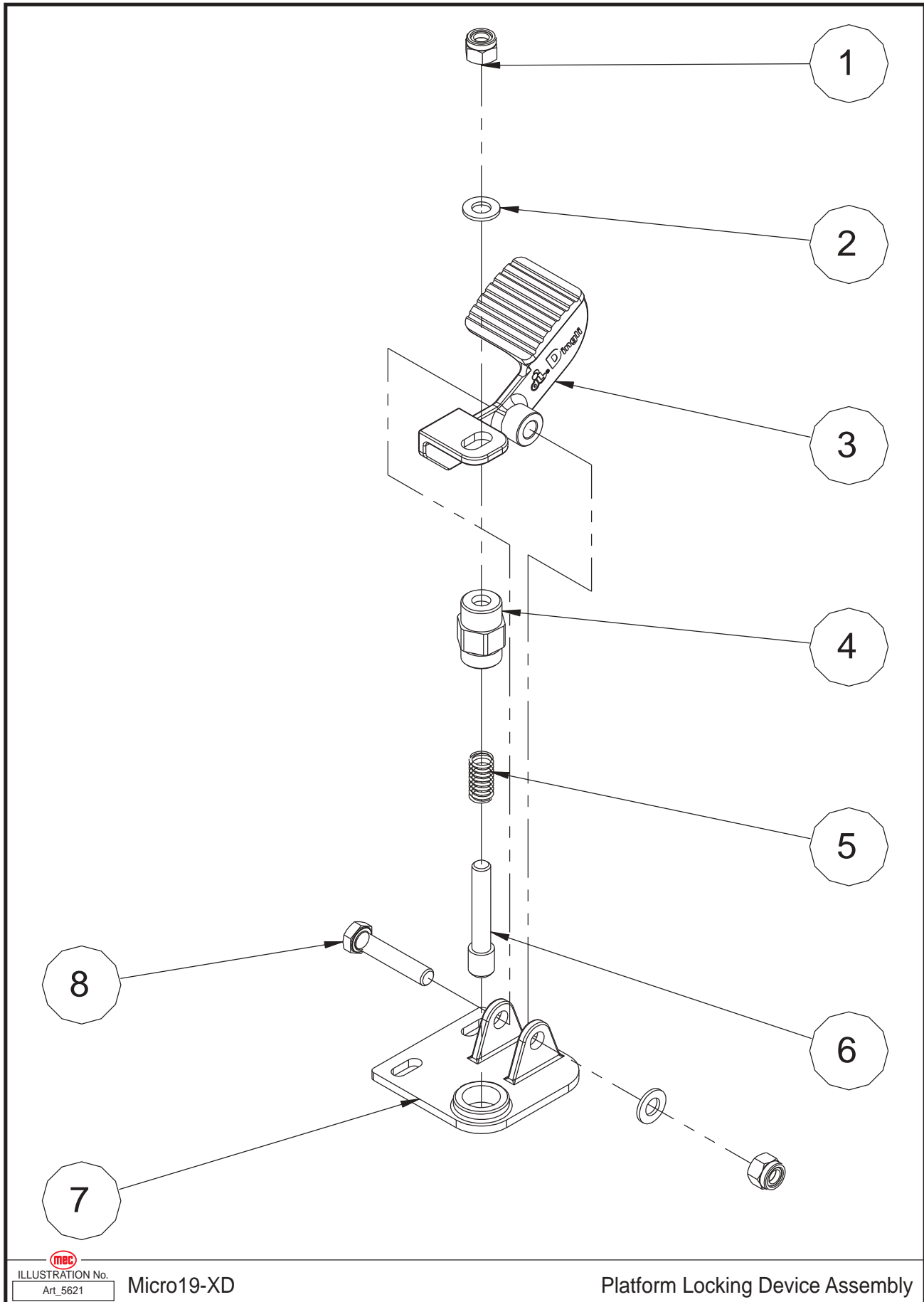

 ILLUSTRATION No. **Micro19-XD**  
Art\_5621

Platform Locking Device Assembly



<b>Item</b>	<b>Part Number</b>	<b>Description</b>	<b>Qty.</b>
1	50049	NNYL M10 × 1.50	2
2	50002	WSHR M10 Standard Flat	2
3	41143	Foot Pedal	1
4	41144	Lock Pin Housing	1
5	41145	Spring	1
6	41146	Lock Pin	1
7	44767	Bracket	1
8	50020	HHCS M10-1.50 × 50	1

# Step Installation

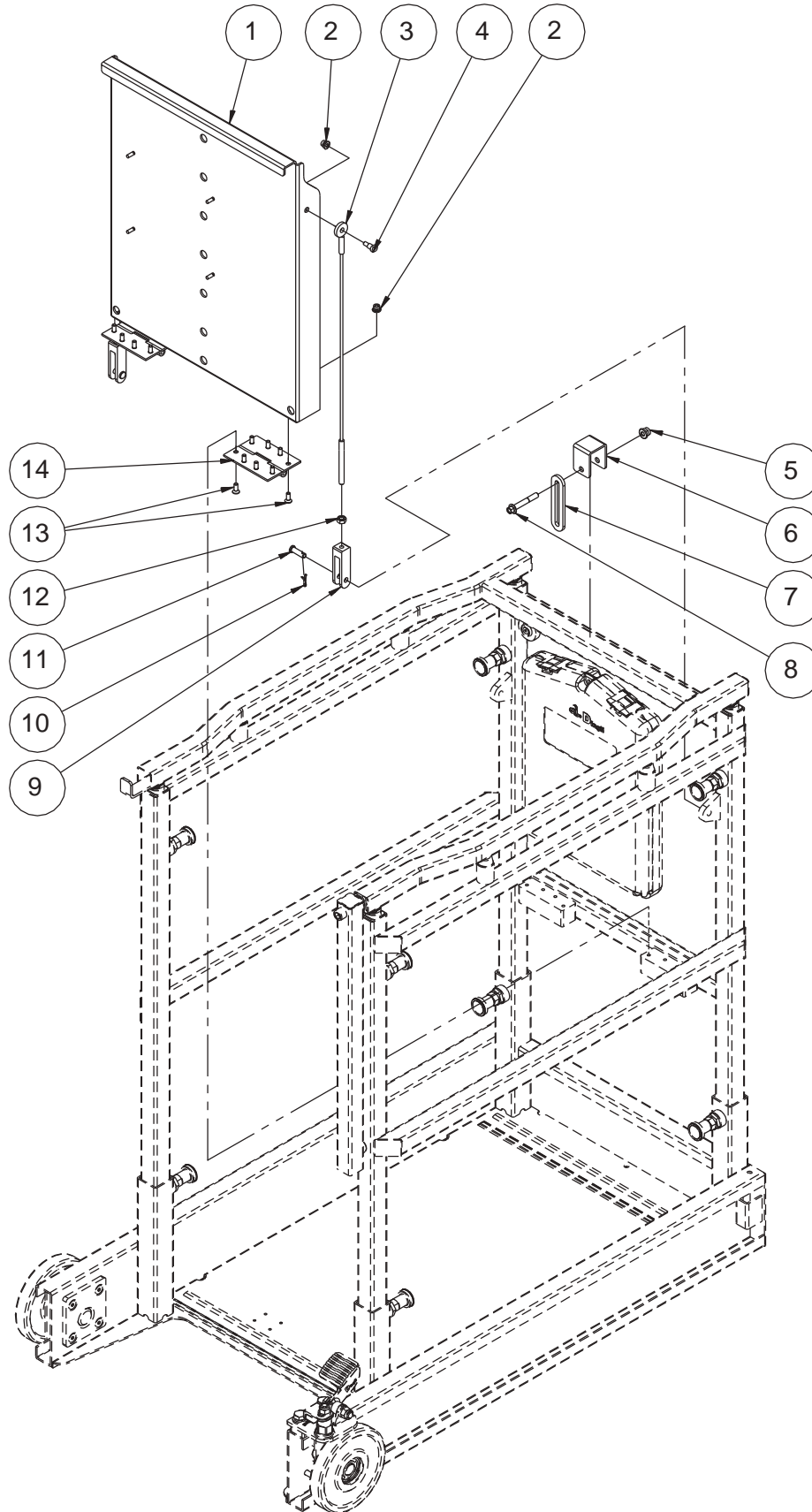

Item	Part Number	Description	Qty.
1	44220	Step Weldment	1
2	50568	NNYL M06-1.00 Flange	10
3	95172	Wire Rope	2
4	53364	Pin	2
5	50313	NNYL M08-1.25 Flange	1
6	44224	Step Sliding Latch Clamp	1
7	44223	Step Sliding Latch	1
8	53359	HHCS M08-1.25 x 55 Flange	1
9	95402	Adjustment Joint	2
10	95403	Cotter Pin	2
11	95404	Pin	2
12	53014	NHEX M08-1.25	2
13	53226	CSCS M06-1.00 x 16	16
14	95405	Hinge	2

# Lower Lift Cylinder Assembly

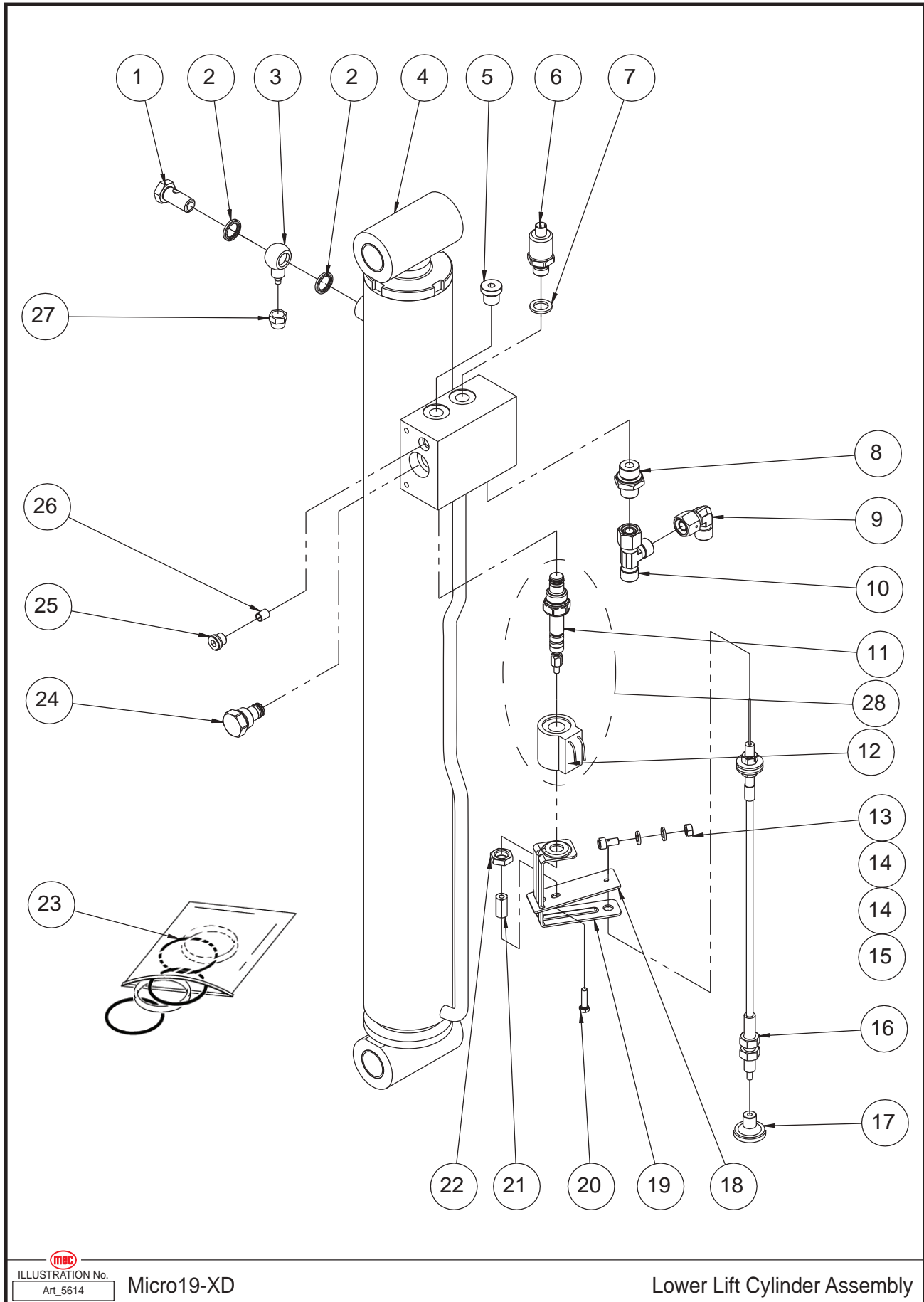

 ILLUSTRATION No. **Micro19-XD**  
Art\_5614

Lower Lift Cylinder Assembly

Item	Part Number	Description	Qty.
1	41166	Fitting	1
2	43361	Washer	2
3	41167	Fitting	1
4	44001	Lower Lift Cylinder	1
5	42480	Plug	1
6	41288	Pressure Sensor	1
7	44002	Washer	1
8	43638	Straight Fitting	1
9	43639	Elbow	1
10	43640	Tee Fitting	1
11	44003	Solenoid Valve Spool	1
12	41747	Coil	1
13	53361	NHEX M06-1.00	1
14	50000	WSHR M06 Standard Flat	2
15	42466	Screw	1
16	42465	Emergency Down Cable Assembly	1
17	41162	Lowering Knob	1
18	41291	Plate	1
19	41292	Support	1
20	53179	HHCS M05-0.80 x 20	1
21	44004	Cable Connector	1
22	53362	NHEX 1/2-20 UNF	1
23	42470	Seal Kit	1
24	43369	Check Valve	1
25	42821	Plug	1
26	43370	Orifice	1
27	41413	Nut	1
28	41746	Valve with Coil	1

# Upper Lift Cylinder Assembly

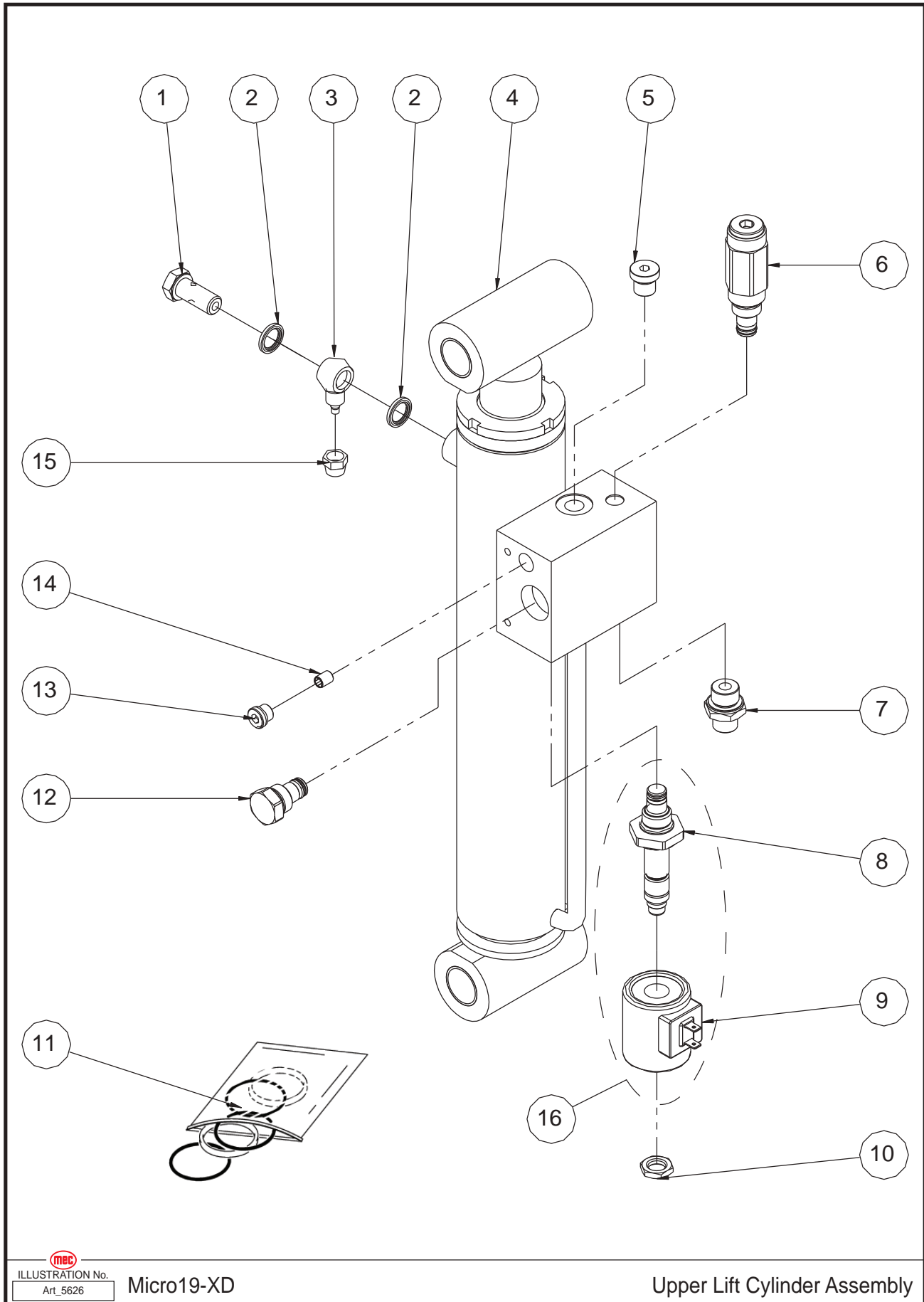
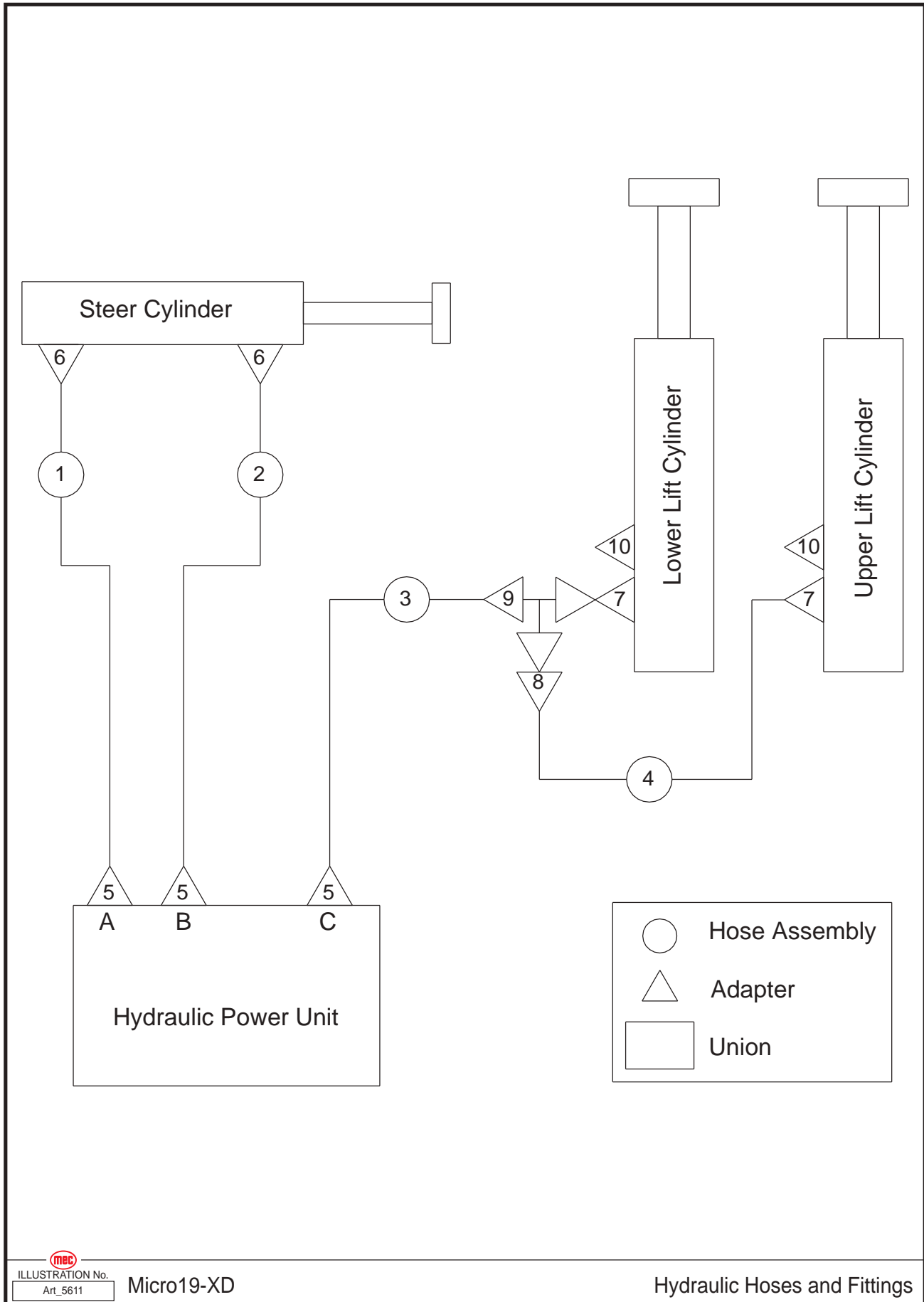

 ILLUSTRATION No. **Micro19-XD**  
Art\_5626

Upper Lift Cylinder Assembly

Item	Part Number	Description	Qty.
1	41166	Fitting	1
2	43361	Washer	2
3	41167	Fitting	1
4	42471	Upper Lift Cylinder	1
5	42480	Plug	1
6	41169	Relief Valve	1
7	43638	Straight Fitting	1
8	43372	Solenoid Valve Spool	1
9	41551	Coil	1
10	42795	Nut	1
11	42475	Seal Kit	1
12	43369	Check Valve	1
13	42821	Plug	1
14	44017	Orifice	1
15	41413	Nut	1
16	42473	Valve with Coil	1

# Hydraulic Hoses and Fittings





<b>Item</b>	<b>Part Number</b>	<b>Description</b>	<b>Qty.</b>
1	42476	Hose Assembly	1
2	42477	Hose Assembly	1
3	42478	Hose Assembly	1
4	44018	Hose Assembly	1
5	41296	Straight Fitting	3
6	41298	Straight Fitting	2
7	43638	Straight Fitting	2
8	43639	Elbow	1
9	43640	Tee Fitting	1
10	42480	Plug	2

# Electrical Harness

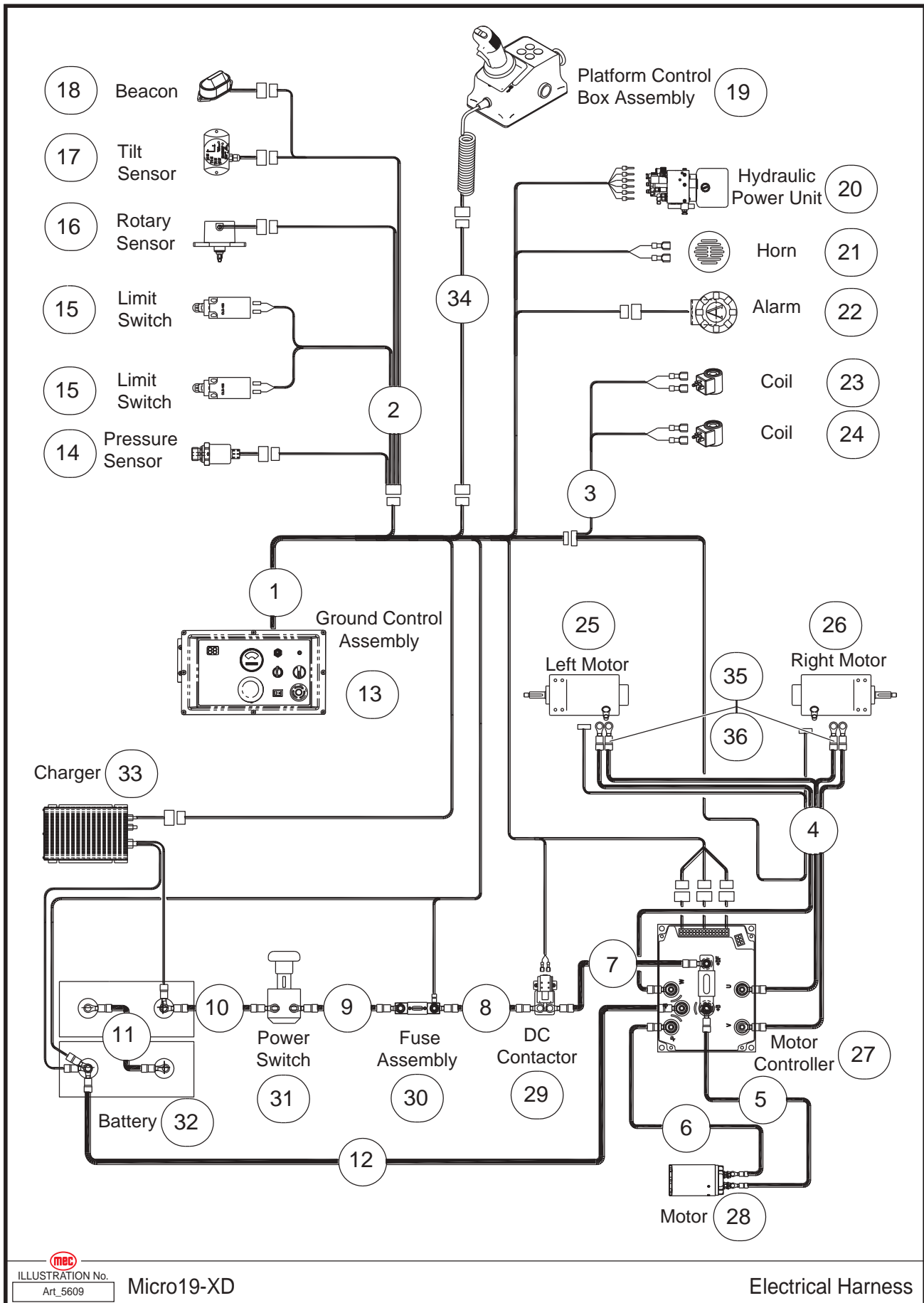

ILLUSTRATION No. **Micro19-XD**  
 Art\_5609

Electrical Harness



Item	Part Number	Description	Qty.
1	42481	ECU Harness	1
2	42540	Accessories Harness	1
3	43755	Lowering Valve Harness	1
4	42484	Drive Motor Harness	1
5	41921	Pump Motor Positive Harness	1
6	41919	Pump Motor Negative Harness	1
7	41917	Motor Controller Harness	1
8	42485	DC Contactor Harness	1
9	42486	Fuse Harness	1
10	42487	Battery Positive Harness	1
11	42488	Battery Harness	1
12	42489	Battery Negative Harness	1
13	REF	Ground Control Assembly (Refer to page 56)	1
14	REF	Pressure Sensor (Refer to page 80)	1
15	REF	Limit Switch, Pothole (Refer to page 58)	2
16	REF	Rotary Sensor (Refer to page 58)	1
17	REF	Tilt Sensor (Refer to page 58)	1
18	REF	Beacon (Refer to page 58)	1
19	REF	Platform Control Box Assembly (Refer to page 74)	1
20	REF	Hydraulic Power Unit (Refer to page 52)	1
21	REF	Horn (Refer to page 50)	1
22	REF	Alarm (Refer to page 50)	1
23	REF	Coil (Refer to page 80)	1
24	REF	Coil (Refer to page 82)	1
25	REF	Left Motor (Refer to page 42 or page 46)	1
26	REF	Right Motor (Refer to page 42 or page 46)	1
27	REF	Motor Controller (Refer to page 54)	1
28	REF	Motor (Refer to page 52)	1
29	REF	DC Contactor (Refer to page 54)	1
30	REF	200A Fuse Assembly (Refer to page 54)	1
31	REF	Power Switch (Refer to page 50)	1
32	REF	Battery (Refer to page 50)	2
33	REF	Charger (Refer to page 50)	1
34	42483	Harness, Communications	1
35	42883	Screw Terminal Connector (Serial #1610100 to 16101800)	2
	47281	Connector, Drive Motor (From Serial #16101801)	2
36	47282	Terminal (For 47281 Only)	4

REF - Reference

# Power to Platform

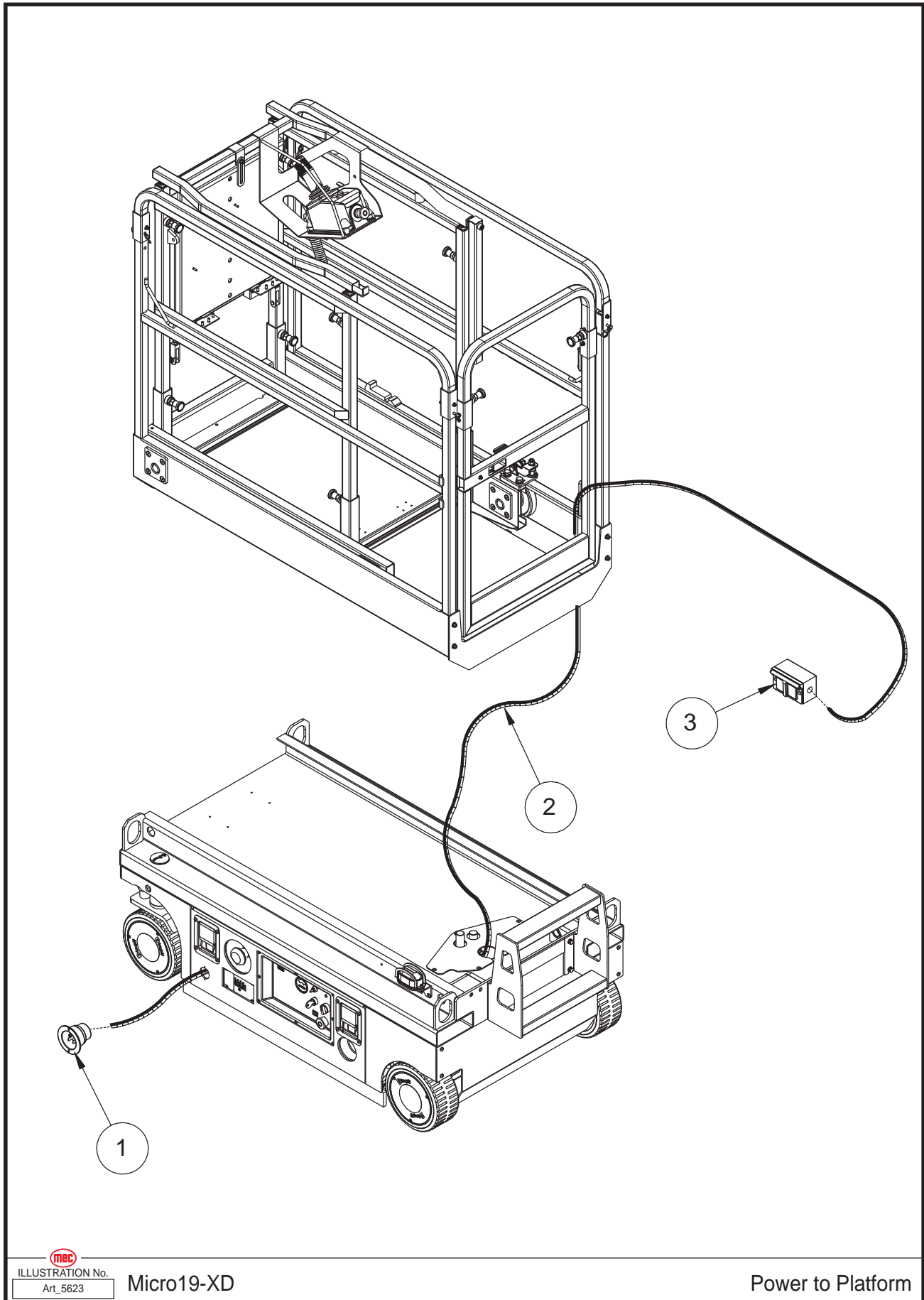

 ILLUSTRATION No. **Micro19-XD**  
Art\_5623

Power to Platform

Item	Part Number	Description	Qty.
1	REF	AC Plug (Refer to page 50)	1
2	44005	Wire Cable, Platform AC Power	1
3	42613	AC Socket	1





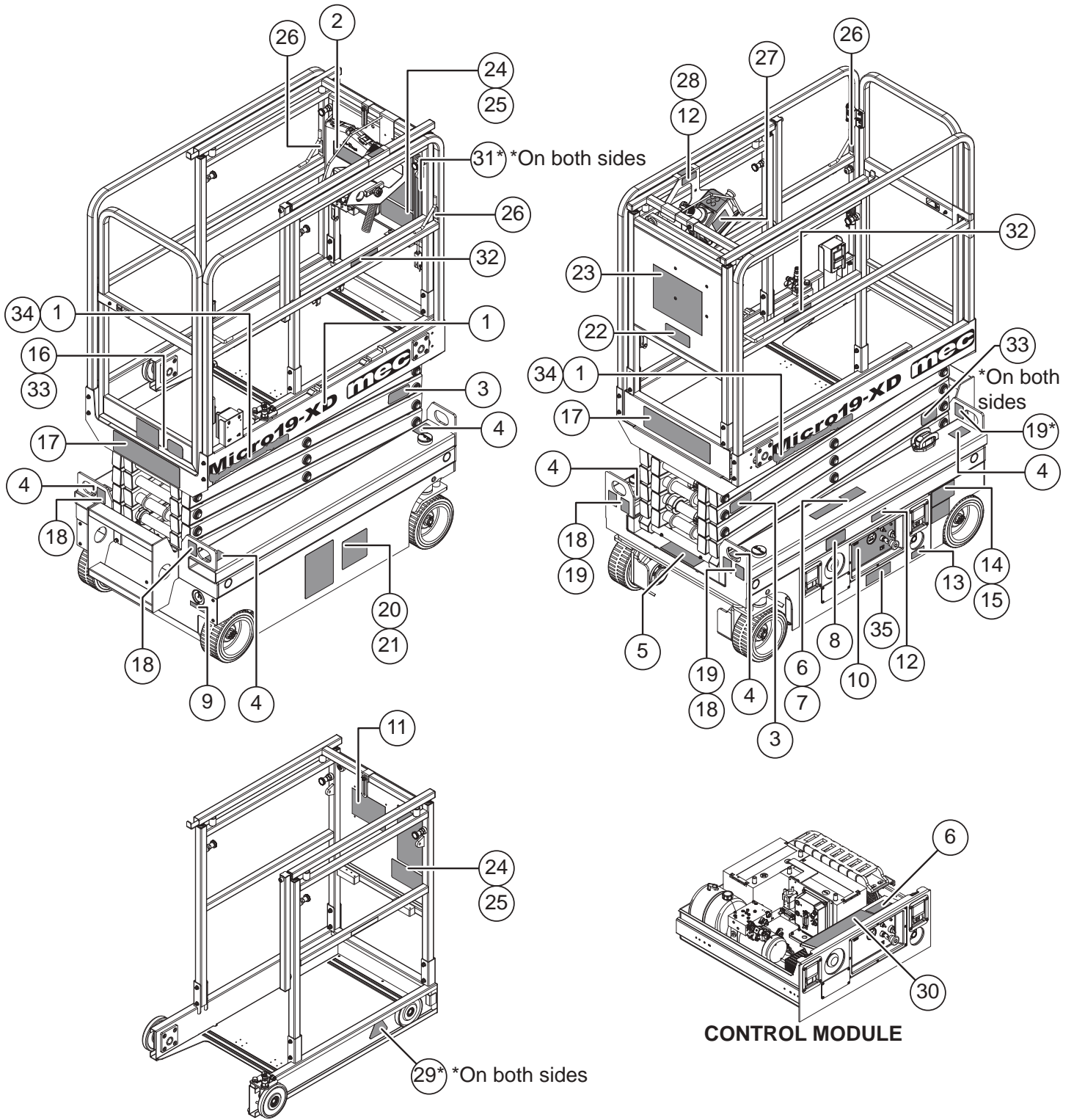





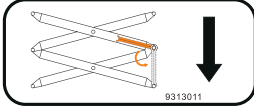
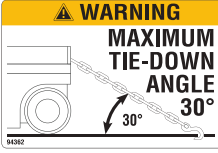

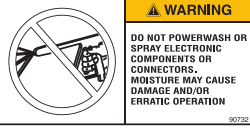
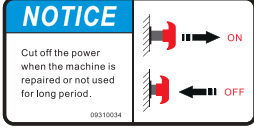
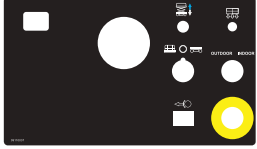







REF - Reference

# Decals

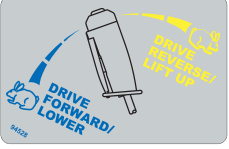

**PLATFORM EXTENDED  
XTRA DECK REMOVED**

**CONTROL MODULE**

<p><b>1</b></p> <p><b>Micro19-XD mec</b></p> <p>95224 Qty. - 2</p>	<p><b>2</b></p> <p><b>XTRA DECK INSTRUCTIONS</b></p> <p>MAXIMUM CAPACITY 2000lb (910kg) 1 PERSON.</p> <p>EXTEND TELESCOPIC GUARDRAILS UNTIL THE BINS SNAP INTO HOLES WHEN THE GUARDRAILS REACH THE EXTENDED POSITION.</p> <p>FOLD DOWN THE XTRA DECK.</p> <p>GROUP AND ENGAGE THE SWAGING TUBE GUARDRAILS ACROSS THE XTRA DECK GUARDRAIL ENTRANCE.</p> <p>STOW FIRST FOLDUP THE XTRA DECK.</p> <p>PULL THE FLANGER PINS, THEN LOWER THE GUARDRAILS TO THE STOWED POSITION.</p> <p>9313011</p> <p>95208 Qty. - 1</p>	<p><b>3</b></p>  <p>9313011</p> <p>41638 Qty. - 2</p>	<p><b>4</b></p> <p><b>WARNING</b></p> <p><b>MAXIMUM TIE-DOWN ANGLE 30°</b></p>  <p>94362 Qty. - 4</p>	<p><b>5</b></p>  <p>95215 Qty. - 1</p>
<p><b>6</b></p>  <p>90732 Qty. - 2</p>	<p><b>7</b></p> <p><b>WARNING</b></p> <p><b>RELEASE BRAKES BEFORE TOWING TO PREVENT DAMAGE TO DRIVE SYSTEM</b></p> <p>42534 Qty. - 1</p>	<p><b>8</b></p> <p><b>NOTICE</b></p> <p>Cut off the power when the machine is repaired or not used for long period.</p>  <p>43910 Qty. - 1</p>	<p><b>9</b></p> <p><b>BATTERY CHARGER AND POWER TO PLATFORM</b></p> <p>94659 Qty. - 1</p>	<p><b>10</b></p>  <p>43903 Qty. - 1</p>
<p><b>11</b></p> <p><b>OPERATOR'S MANUAL AND SAFE WORKING INSTRUCTIONS LOCATED UNDER STEP</b></p> <p>95389 Qty. - 1</p>	<p><b>12</b></p> <p>Refer the operator to the instructions for use.</p> <p>9314013</p> <p>41639 Qty. - 2</p>	<p><b>13</b></p> <p><b>EMERGENCY LOWER</b></p> <p>Pull knob to lower platform</p> <p>9311017</p> <p>41636 Qty. - 1</p>	<p><b>14</b></p> <p><b>WARNING</b></p> <p><b>Tip-over Hazard</b></p> <p>Do not use batteries that weigh less than the original equipment. Batteries are used as counterweight and are critical to machine stability. Each battery must weigh 72 lbs / 32.7 kg. The batteries must weigh a minimum of 144 lbs / 65.4 kg.</p> <p>9411061UM</p> <p>42493 Qty. - 1</p>	<p><b>15</b></p> <p><b>MICRO 19 BRAKE RELEASE INSTRUCTIONS</b></p> <ol style="list-style-type: none"> <li>1- Check the vehicle.</li> <li>2- Turn Key Switch to OFF position.</li> <li>3- Ensure both upper and lower E-Stops are on.</li> <li>4- Press and hold Brake Rocker Switch (A) and Lift/Lower Switch (B) down. Turn the Key Switch to the Ground position.</li> <li>5- Hold Brake Rocker Switch (A) and Lift/Lower Switch (B) until a continuous alarm sounds, confirming brakes are released.</li> <li>6- Press an E-Stop or return the Key Switch to the OFF position to reset the brakes.</li> </ol> <p>94846 Qty. - 1</p>
<p><b>16</b></p>  <p>95301 Qty. - 1</p>	<p><b>17</b></p>  <p>43886 Qty. - 2</p>	<p><b>18</b></p>  <p>9311015</p> <p>41635 Qty. - 4</p>	<p><b>19</b></p>  <p>9311013</p> <p>41634 Qty. - 4</p>	<p><b>20</b></p> <p><b>WARNING</b></p>  <p>41649 Qty. - 1</p>
<p><b>21</b></p> <p><b>DANGER</b></p>  <p>41641 Qty. - 1</p>	<p><b>22</b></p> <p><b>mec DIRECT ELECTRIC DRIVE</b></p>  <p>94423 Qty. - 1</p>	<p><b>23</b></p>  <p>MEC AERIAL WORK PLATFORMS 1401 S. MADERA AVE, KERNAN, CA 93630 USA 1-800-840-1500 www.MECapp.com</p> <p>90719 Qty. - 1</p>	<p><b>24</b></p> <p><b>DANGER</b></p>  <p>43885 Qty. - 2</p>	<p><b>25</b></p> <p><b>DANGER</b></p> <p><b>Tip-over Hazard</b></p>  <p>41647 Qty. - 2</p>
<p><b>26</b></p>  <p>9414123UM</p> <p>41648 Qty. - 3</p>	<p><b>27</b></p>  <p>94528 Qty. - 2</p>	<p><b>28</b></p> <p>Platform controller normal position.</p> <p>9314015</p> <p>41640 Qty. - 1</p>	<p><b>29</b></p>  <p>91850 Qty. - 2</p>	<p><b>30</b></p>  <p>43879 Qty. - 1</p>
<p><b>31</b></p> <p><b>XTRA DECK</b></p> <p>95188 Qty. - 2</p>	<p><b>32</b></p> <p><b>PATENT PENDING</b></p> <p>94865 Qty. - 2</p>	<p><b>33</b></p> <p><b>MEC - Model Info</b></p> <p>Text Micro19XD to 1 (844) 483-4669</p>  <p>Manuals Brochures Warranty &amp; More</p> <p>95253 Qty. - 2</p>	<p><b>34</b></p> <p><b>Leak Containment System</b></p>  <p>94866 Qty. - 2</p>	<p><b>35</b></p> <p><b>Leak Containment System</b></p>  <p>94867 Qty. - 1</p>

---

# Notes



---

# Notes





## Limited Owner Warranty

MEC Aerial Platform Sales Corp. warrants its equipment to the original purchaser against defects in material and/or workmanship under normal use and service for one (1) year from date of registered sale or date the unit left the factory if not registered. MEC Aerial Platform Sales Corp. further warrants the structural weldments of the main frame and scissor arms to be free from defects in material or workmanship for five (5) years from date of registered sale or date unit left the factory if not registered. Excluded from such warranty is the battery(s) which carries a ninety (90) day warranty from described purchase date. Warranty claims within such warranty period shall be limited to repair or replacement, MEC Aerial Platform Sales Corp's option, of the defective part in question and labor to perform the necessary repair or replacement based on MEC Aerial Platform Sales Corp's then current flat rate, provided the defective part in question is shipped prepaid to MEC Aerial Platform Sales Corp. and is found upon inspection by MEC Aerial Platform Sales Corp. to be defective in material and/or workmanship. MEC Aerial Platform Sales Corp. shall not be liable for any consequential, incidental or contingent damages whatsoever. Use of other than factory authorized parts; misuse, improper maintenance, or modification of the equipment voids this warranty. The foregoing warranty is exclusive and in lieu of all other warranties, express or implied. All such other warranties, including implied warranties of merchantability and of fitness for a particular purpose, are hereby excluded. No Dealer, Sales Representative, or other person purporting to act on behalf of MEC Aerial Platform Sales Corp. is authorized to alter the terms of this warranty, or in any manner assume on behalf of MEC Aerial Platform Sales Corp. any liability or obligation which exceeds MEC Aerial Platform Sales Corp's obligations under this warranty.



# MEC Aerial Work Platforms

---

1401 S. Madera Avenue, Kerman, CA 93630 USA

Toll Free: 1-877-632-5438

Phone: 1-559-842-1500

Fax: 1-559-842-1520

[info@MECawp.com](mailto:info@MECawp.com)

[www.MECawp.com](http://www.MECawp.com)